

SERVICE MANUAL

WAX2T CHASSIS

<i>MODEL</i>	<i>COMMANDER</i>	<i>DEST</i>	<i>MODEL</i>	<i>COMMANDER</i>	<i>DEST</i>
KDL-32S2510	RM-ED008	AEP	KDL-32S2510	RM-ED008	UK
KDL-40S2510	RM-ED008	AEP	KDL-40S2510	RM-ED008	UK
KDL-46S2510	RM-ED008	AEP	KDL-46S2510	RM-ED008	UK
KDL-32S2520	RM-ED008	AEP	KDL-32S2520	RM-ED008	UK
KDL-32S2530	RM-ED008	AEP	KDL-32S2530	RM-ED008	UK
KDL-40S2530	RM-ED008	AEP	KDL-40S2530	RM-ED008	UK
KDL-46S2530	RM-ED008	AEP	KDL-46S2530	RM-ED008	UK



KDL-32S2510 / KDL-40S2510 / KDL-46S2510 / KDL-32S2520
KDL-32S2530 / KDL-40S2530 / KDL-46S2530



RM-ED008

FLAT PANEL COLOR TV
SONY®

TABLE OF CONTENTS

Section	Title	Page	Section	Title	Page
	Caution	3	3-6.	Board Replacement	28
	Specifications	4	3-6-1.	AE Board Replacement	28
	Connectors	6	3-6-2.	B2H Board Replacement	28
	Self Diagnosis	7			
1.	GENERAL	8	4.	DIAGRAMS	
2.	DISASSEMBLY		4-1.	Block Diagrams(1)	29
2-1.	Rear Cover Removal	18		Block Diagrams(2)	30
2-2.	Stand Removal	18		Block Diagrams(3)	31
2-3.	Vesa Bracket Removal	19		Block Diagrams(4)	32
2-4.	AC Inlet Removal	19	4-2.	Circuit Board Location	33
2-5.	Speaker Removal	20	4-3.	Schematic Diagrams and Printed Wiring	
2-6.	AE and TUE Board Removal	20		Boards	33
2-7.	B2H and FEE Board Removal	21		AE Board Schematic Diagram	34
2-8.	G1 or G2A Board Removal	21		AE Printed Wiring Board	38
2-9.	H1E Board Removal	22		B2H Board Schematic Diagram	40
2-10.	H2E or H46E Board Removal	22		B2H Printed Wiring Board	50
2-11.	H3E Board Removal	23		FEE Board Schematic Diagram	52
2-12.	LCD Panel Removal	23		FEE Printed Wiring Board	58
3.	SET-UP ADJUSTMENTS			G2A Board Schematic Diagram	
3-1.	How to enter Service Mode	24		(40 and 46 inch only)	59
3-2.	Signal Level Adjustment	24		G2A Printed Wiring Board	
3-2-1.	Set up of AD calibration1 adjustment for			(40 and 46 inch only)	60
	terrestrial analog	24		H1E Board Schematic Diagram	62
3-2-2.	Y signal calibration1 adjustment for			H1E Printed Wiring Board	63
	terrestrial analog	24		H2E Board Schematic Diagram	
3-2-3.	Set up of C signal calibration1 adjustment for			(32 and 40 inch only)	62
	terrestrial analog	24		H2E Printed Wiring Board	
3-2-4.	C signal calibration1 adjustment for			(32 and 40 inch only)	63
	terrestrial analog	25		H3E Board Schematic Diagram	62
3-2-5.	Set up of AD calibration1 adjustment for			H3E Printed Wiring Board	63
	video	25		H46E Board Schematic Diagram	
3-2-6.	Y signal calibration1 adjustment for video	25		(46 inch only)	64
3-2-7.	Set up of C signal calibration1 adjustment for			H46E Printed Wiring Board	
	video	25		(46 inch only)	63
3-2-8.	C signal calibration1 adjustment for video	25		TUE Schematic Diagram	64
3-2-9.	Set up of AD calibration2 adjustment for			TUE Printed Wiring Board	66
	video	25	4-4.	Semiconductors	67
3-2-10.	Y signal calibration2 adjustment for video	25	5.	EXPLODED VIEWS	
3-2-11.	Set up of C signal calibration2 adjustment for		5-1.	Chassis	69
	video	26	5-2.	Rear Cover, Stand and Vesa Bracket	71
3-2-12.	C signal calibration2 adjustment for video	26	6.	ELECTRICAL PARTS LIST	73
3-3.	Gamma Adjustment	26			
3-3-1.	Set up mode for Gamma Adjustment	26			
3-3-2.	Set up Trident internal SG and brightness				
	measurement	26			
3-4.	White Balance Adjustment	26			
3-4-1.	Set up mode for White Balance Adjustment	26			
3-4-2.	White Balance of colour temperature "Cool"	26			
3-4-3.	White Balance of colour temperature "Neutral"	27			
3-4-4.	White Balance of colour temperature "Warm1"	27			
3-4-5.	White Balance of colour temperature "Warm2"	28			
3-5.	Panel Replacement	28			

WARNING !!

AN ISOLATION TRANSFORMER SHOULD BE USED DURING ANY SERVICE WORK TO AVOID POSSIBLE SHOCK HAZARD DUE TO LIVE CHASSIS, THE CHASSIS OF THIS RECEIVER IS DIRECTLY CONNECTED TO THE POWER LINE.

SAFETY-RELATED COMPONENT WARNING !!

COMPONENTS IDENTIFIED BY SHADING AND MARKED Δ ON THE SCHEMATIC DIAGRAMS, EXPLODED VIEWS AND IN THE PARTS LIST ARE CRITICAL FOR SAFE OPERATION. REPLACE THESE COMPONENTS WITH SONY PARTS WHOSE PART NUMBERS APPEAR AS SHOWN IN THIS MANUAL OR IN SUPPLEMENTS PUBLISHED BY SONY.

CAUTION

Lead Free Soldered Boards

The circuit boards used in these models have been processed using Lead Free Solder. The boards are identified by the LF logo located close to the board designation e.g. F1, H1 etc [see examples]. The servicing of these boards requires special precautions to be taken as outlined below.



example 1

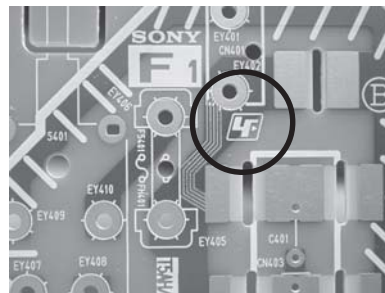

example 2



It is strongly recommended to use Lead Free Solder material in order to guarantee optimal quality of new solder joints. Lead Free Solder is available under the following part numbers :

Partnumber	Diameter	Remarks
7-640-005-19	0.3mm	0.25Kg
7-640-005-20	0.4mm	0.50Kg
7-640-005-21	0.5mm	0.50Kg
7-640-005-22	0.6mm	0.25Kg
7-640-005-23	0.8mm	1.00Kg
7-640-005-24	1.0mm	1.00Kg
7-640-005-25	1.2mm	1.00Kg
7-640-005-26	1.6mm	1.00Kg

Due to the higher melting point of Lead Free Solder the soldering iron tip temperature needs to be set to 370 degrees centigrade. This requires soldering equipment capable of accurate temperature control coupled with a good heat recovery characteristics.

For more information on the use of Lead Free Solder, please refer to <http://www.sony-training.com>

ITEM MODEL	Television System	Stereo System	Channel Coverage	Color System
E	B/G/H, D/K, I, L, DVB-T	GERMAN/NICAM Stereo	VHF : E02-E12 UHF : E21-E69 CATV : S01-S20 HYPER : S21-S41 D/K : R1-R12, R21-R69 L : F2-F10, B-Q, F21-F69 I : UHF B21-B69	PAL, SECAM NTSC 3.58/4.43 (VIDEO ONLY) MPEG-2 MP@ML
U	I, DVB-T	NICAM Stereo	UHF : B21-B69	PAL, SECAM NTSC 3.58/4.43 (VIDEO ONLY) MPEG-2 MP@ML

Projected Picture Size	LCD(Liquid Crystal Display) Panel Approx 80.1cm (32 inches) Approx 101.6cm (40 inches) Approx 116.9cm (46 inches)	Sound Output	
		Right and Left speaker Sub-woofer	2 x 10W (RMS)
Input/Output Terminals [REAR]		General Specifications	
1: 21-pin Euro connector (CENELEC standard)	Inputs for Audio and Video signals. Inputs for RGB. Outputs of TV Video and Audio signals.	Power Requirements	220 - 240V
		Power Consumption/ Standby	Approx 125W/0.3W (32inch) Approx 180W/0.3W (40inch) Approx 220W/0.3W (46inch)
2: 21-pin Euro connector (CENELEC standard)	Inputs for Audio and Video signals. Inputs for RGB. Outputs of Video and Audio signals (Selectable). SmartLink interface.	Dimensions	Approx 792x593x219mm (32inch with stand) Approx 792x546x99mm (32inch without stand) Approx 988x716x334mm (40inch with stand) Approx 988x664x103mm (40inch without stand) Approx 1120x805x334mm (46inch with stand) Approx 1120x755x116mm (46inch without stand)
		Weight	Approx 17kg (32inch with stand) Approx 15kg (32inch without stand) Approx 27kg (40inch with stand) Approx 21kg (40inch without stand) Approx 34kg (46inch with stand) Approx 28kg (46inch without stand)
Phono Jacks	Output Connectors variable for Audio Signals.	Supplied Accessories	RM-ED008 Remote Commander (1) IEC designated R06 battery (2) Mains lead (1) Coaxial cable (1) Cable holder (1) Support belt (1) and screws (2)
HDMI Inputs	HDMI Connectors.	Other Features	Wide viewing angle LCD Panel, Intergrated digital TV Tuner, Live colour creation, BBE digital, Trusurround XT, 2 HDMI inputs, PC input.
PC Input	15 Pin D-Sub Connector.		
CAM	Conditional Access Module		
Input/Output Terminals [SIDE]		Remote control system : Infrared control	
Headphone jack	Stereo mini jack	Power requirements	3V dc 2 batteries IEC designation R06 (size AA)
Audio input	Phono jacks		
Video input	Phono jack		
S Video input	4 pin mini DIN		
Design and specifications are subject to change without notice.			

Model Name Item	KDL-32S2510 KDL-40S2510 KDL-46S2510 (AEP)	KDL-32S2510 KDL-40S2510 KDL-46S2510 (UK)	KDL-32S2520 (AEP)	KDL-32S2520 (UK)	KDL-32S2530 KDL-40S2530 KDL-46S2530 (AEP)	KDL-32S2530 KDL-40S2530 KDL-46S2530 (UK)
PAP	OFF	OFF	OFF	OFF	OFF	OFF
PAT	OFF	OFF	OFF	OFF	OFF	OFF
RGB Priority	ON	ON	ON	ON	ON	ON
Sub Woofer	OFF	OFF	OFF	OFF	OFF	OFF
Scart 1	ON	ON	ON	ON	ON	ON
Scart 2	ON	ON	ON	ON	ON	ON
Front in (6)	ON	ON	ON	ON	ON	ON
Projector	OFF	OFF	OFF	OFF	OFF	OFF
Norm B/G	ON	OFF	ON	OFF	ON	OFF
Norm I	ON	ON	ON	ON	ON	ON
Norm D/K	ON	OFF	ON	OFF	ON	OFF
Norm AUS	OFF	OFF	OFF	OFF	OFF	OFF
Norm L	ON	OFF	ON	OFF	ON	OFF
Norm SAT	OFF	OFF	OFF	OFF	OFF	OFF
Norm M	OFF	OFF	OFF	OFF	OFF	OFF
Teletext	ON	ON	ON	ON	ON	ON
Nicam Stereo	ON	ON	ON	ON	ON	ON

WARNING (UK Models only)

The flexible mains lead is supplied connected to a **B.S. 1363** fused plug having a fuse of **13 AMP** rating. Should the fuse need to be replaced, use a **13AMP FUSE** approved by ASTA to **BS 1362**, ie one that carries the  mark.

IF THE PLUG SUPPLIED WITH THIS APPLIANCE IS NOT SUITABLE FOR THE OUTLET SOCKETS IN YOUR HOME, IT SHOULD BE CUT OFF AND AN APPROPRIATE PLUG FITTED. THE PLUG SEVERED FROM THE MAINS LEAD MUST BE DESTROYED AS A PLUG WITH BARED WIRES IS DANGEROUS IF ENGAGED IN A LIVE SOCKET.

When an alternative type of plug is used, it should be fitted with a **13 AMP FUSE**, otherwise the circuit should be protected by a **13AMP FUSE** at the distribution board.

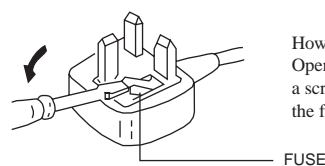

How to replace the fuse.
Open the fuse compartment with a screwdriver blade and replace the fuse.

21 pin connector

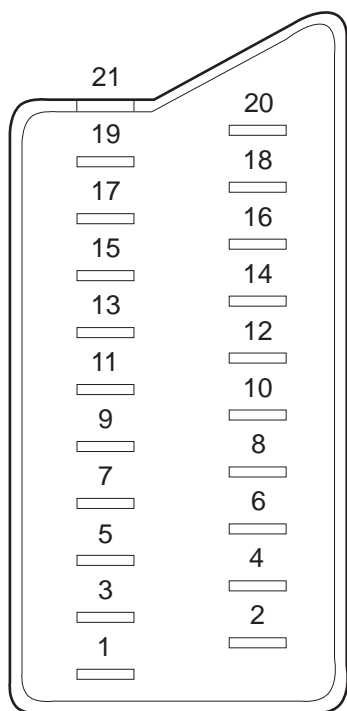

Pin No	1	2	Signal	Signal level
1	○	○	Audio output B (right)	Standard level : 0.5V rms Output impedance : Less than 1kohm*
2	○	○	Audio input B (right)	Standard level : 0.5V rms Output impedance : More than 10kohm*
3	○	○	Audio output A (left)	Standard level : 0.5V rms Output impedance : Less than 1kohm*
4	○	○	Ground (audio)	
5	○	○	Ground (blue)	
6	○	○	Audio input A (left)	Standard level : 0.5V rms Output impedance : More than 10kohm*
7	○	○	Blue input	0.7 +/- 3dB, 75 ohms positive
8	○	○	Function select (AV control)	High state (9.5-12V) : Part mode Low state (0-2V) : TV mode Input impedance : More than 10K ohms Input capacitance : Less than 2nF
9	○	○	Ground (green)	
10	●	○	AVlink	
11	○	○	Green	Green signal : 0.7 +/- 3dB, 75 ohms, positive
12	●	●	Open	
13	○	○	Ground (red)	
14	○	○	Ground (blanking)	
15	○	○	Red input	0.7 +/- 3dB, 75 ohms, positive
	-	-	(S signal Chroma input)	0.3 +/- 3dB, 75 ohms, positive
16	○	○	Blanking input (Y's signal)	High state (1-3V) Low state (0-0.4V) Input impedance : 75 ohms
17	○	○	Ground (video output)	
18	○	○	Ground (video input)	
19	○	○	Video output	1V +/- 3dB, 75ohms, positive sync 0.3V (-3+10dB)
20	○	○	Video input	1V +/- 3dB, 75ohms, positive sync 0.3V (-3+10dB)
	-	-	Video input Y (S signal)	1V +/- 3dB, 75ohms, positive sync 0.3V (-3+10dB)
21	○	○	Common ground (plug, shield)	

○ Connected ● Not Connected (open) * at 20Hz - 20kHz

Rear Connection Panel



Side Connection Panel



S-Video socket

S Video socket pin configuration		
Pin No	Signal	Signal Level
1	Ground	-
2	Ground	-
3	Y (S signal) input	1V +/- 3dB 75ohm, positive Sync. 0.3V -3 +10dB
4	C (S signal) input	0.3V +/- 3dB 75ohm, positive Sync.

WAX2T SELF DIAGNOSTIC SOFTWARE

The identification of errors within the WAX2T chassis is triggered in one of two ways :- 1: Busy or 2: Device failure to respond to IIC. In the event of one of these situations arising the software will first try to release the bus if busy (Failure to do so will report with a continuous flashing LED) and then communicate with each device in turn to establish if a device is faulty. If a device is found to be faulty the relevant device number will be displayed through the LED (Series of flashes which must be counted).

Flash Timing Example : e.g. error number 3

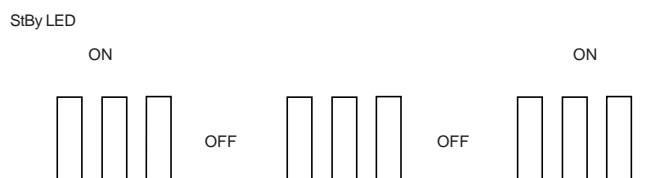

LED Error Code

LED ERROR CODE	ERROR DESCRIPTION
1	UNREG33V Supply Voltage Trouble (DCALERT3)
2	VD1.8, DE5V/6V Voltage Trouble (DCALERT2)
3	UNREG10.5V, PANEL5V Voltage Trouble (DCALERT1)
4	Backlight Trouble
5	Main Supply Voltage Trouble
6	Speaker Applied Voltage Trouble
7	Monitor an Increase in Inside-Temperature (esp. on the panel side)
8	Trident IC Trouble
9	DTT Trouble (Communications / BS_CS_PROT)

SECTION 1 GENERAL

The operating instructions mentioned here are partial abstracts from the Operating Instruction Manual. The page numbers of the Operating Instruction Manual remain as in the manual.

1: Checking the accessories

- Remote RM-ED008 (1)
- Size AA batteries (R6 type) (2)
- Mains lead (Type C-6) (1)

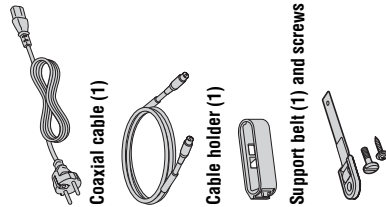

To insert batteries into the remote

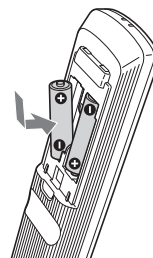

Notes

- Observe the correct polarity when inserting batteries.
- Dispose of batteries in an environmentally friendly way.
- Certain regions may regulate disposal of the battery. Please consult your local authority.
- Do not use different types of batteries together or mix old and new batteries.
- Handle the remote with care. Do not drop or step on it, or spill liquid of any kind onto it.
- Do not place the remote in a location near a heat source, or in a place subject to direct sunlight, or in a damp room.

2: Connecting an aerial/VCR

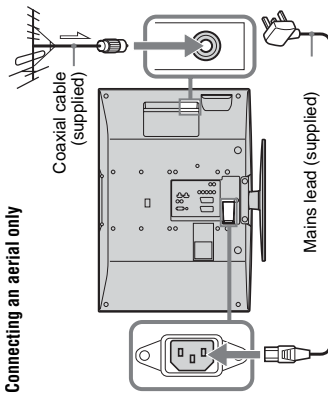

Connecting an aerial and VCR

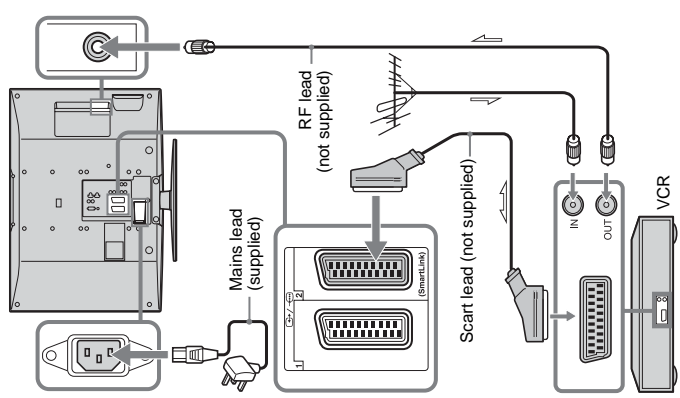

3: Bundling the cables

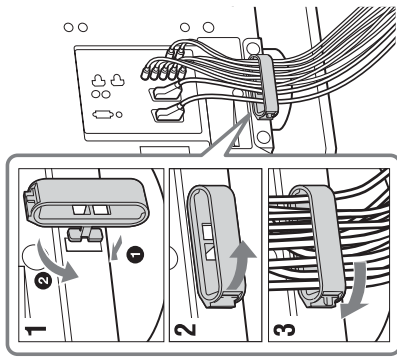

5: Selecting the language and country/region

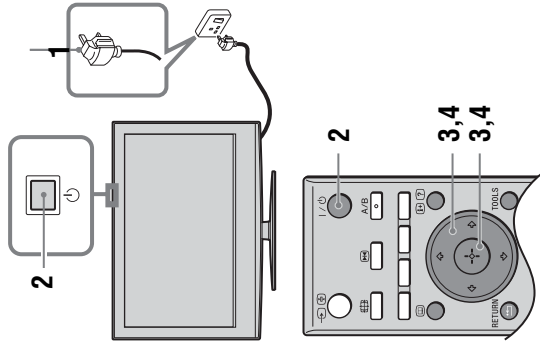

- 1 Connect the TV to your mains socket (220-240V AC, 50Hz).
- 2 Press on the TV (top side).
When you switch on the TV for the first time, the Language menu appears on the screen.
When the TV is in standby mode (the indicator on the TV (front) is red), press on the remote to switch on the TV.

4: Preventing the TV from toppling over

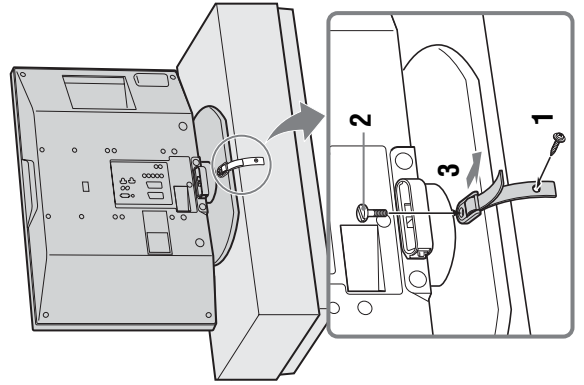

Continued

- 3 Press \uparrow/\downarrow to select the language displayed on the menu screens, then press \odot .



- 4 Press \uparrow/\downarrow to select the country/region in which you will operate the TV, then press \odot .



If the country/region in which you want to use the TV does not appear in the list, select “:” instead of a country/region.
The message confirming the TV start auto-tuning appears on the screen, then go to “6: Auto-tuning the TV”.

6: Auto-tuning the TV

The TV will now search for and store all available TV channels.

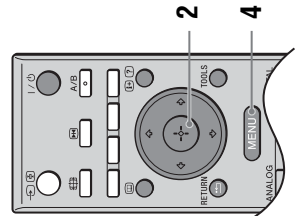

Watching TV

Watching TV

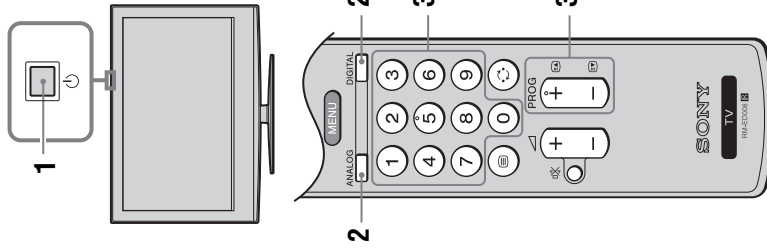

- 3 Press the number buttons or PROG \uparrow/\downarrow to select a TV channel.
To select channel numbers 10 and above using the number buttons, enter the second and third digits within two seconds.
To select a digital channel using the Digital Electronic Programme Guide (EPG), see page 15.

In digital mode

An information banner appears briefly. The following icons may be indicated on the banner.

- : Radio service
- : Scrambled/Subscription service
- : Multiple audio languages available
- : Subtitles available
- : Subtitles available for the hearing impaired
- : Recommended minimum age for current programme (from 4 to 18 years)
- : Parental Lock
- : Current programme is being recorded

Additional operations

To	Do this
Turn off the TV temporarily (Standby mode)	Press I/⏻.
Turn on the TV from Standby mode without sound	Press \mathcal{O} . Press \uparrow/\downarrow to set the volume level.
Turn off the TV completely	Press \odot on the TV (top side).
Adjust the volume	Press \leftarrow + (increase)/ - (decrease).
Mute the sound	Press \mathcal{O} . Press again to restore.
Access the Programme index table (in analogue mode only)	Press \oplus . To select an analogue channel, press \uparrow/\downarrow , then press \oplus . To access the Input signal index table, see page 18.

- 1 Press \odot on the TV (top side) to switch on the TV.
When the TV is in standby mode (the \odot (standby) indicator on the TV (front) is red), press I/⏻ on the remote to switch on the TV.
- 2 Press DIGITAL to switch to digital mode or ANALOG to switch to analogue mode.
The channels available vary depending on the mode.

- 1 Before you start auto-tuning the TV, insert a pre-recorded tape into the VCR connected to the TV (page 4) and start play back.

The video channel will be located and stored on the TV during auto-tuning.
If no VCR is connected to the TV, this procedure is not required. Go to step 2.

- 2 Select “OK”, then press \oplus .



The TV starts searching for all available digital channels, followed by all available analogue channels. This may take some time, please be patient and do not press any buttons on the TV or remote.

If a message appears for you to confirm the aerial connections

No digital or analogue channels were found. Check all the aerial connections and press \oplus to start auto-tuning again.

- 3 When the Programme Sorting menu appears on the screen, follow the steps of “Programme Sorting” (page 28).

If you do not wish to change the order in which the analogue channels are stored on the TV, go to step 4.

- 4 Press MENU to exit.

The TV has now tuned in all the available channels.

Checking the Digital Electronic Programme Guide (EPG) DV3*



- In digital mode, press **[D]** to display the Digital Electronic Programme Guide (EPG).
- Perform the desired operation, as shown in the following table.

Note

Programme information will only be displayed if the TV station is transmitting it.

Digital Electronic Programme Guide (EPG)

* Please note that this function may not be available in some countries.

To

- Turn off the EPG: Press **[D]**.
- Move through the EPG: Press **[Left]**, **[Right]**, **[Up]**, **[Down]**.
- Watch a current programme: Press **[Enter]** while the current programme is selected.
- Sort the programme information by category – Category list:
 - Press the blue button.
 - Press **[Left]**/**[Right]**/**[Up]**/**[Down]** to select a category. The category name is displayed on the side.
The categories available include:
"Favourite": Contains all the channels that have been stored in the Favourite list (page 17).
"All Categories": Contains all available channels.
"News": Contains all news channels.
 - Press **[Enter]**.
The Digital Electronic Programme Guide (EPG) now only displays the current programmes from the category selected.

Set a programme to be recorded – Timer REC

- Press **[Left]**/**[Right]**/**[Up]**/**[Down]** to select the future programme you want to record.
- Press **[Enter]**.
- Press **[Left]**/**[Right]** to select "Timer REC".
- Press **[Enter]** to set the TV and your VCR timers.
A **[D]** symbol appears by that programme's information. The **[D]** indicator on the TV (front) lights up.

Notes

- You can set VCR timer recording on the TV only for Smartlink compatible VCRs. If your VCR is not Smartlink compatible, a message will be displayed to remind you to set your VCR timer.
- Once a recording has begun, you can switch the TV to standby mode, but do not switch off the TV completely or the recording may be cancelled.
- If an age restriction for programmes has been selected, a message asking for pin code will appear on the screen. For more details refer to "Parental Lock" on page 32.

Using the Tools menu

Press **TOOLS** to display the following options when viewing pictures from connected equipment other than PC.

Options	Description
Power Saving	See page 26.
Picture Mode	See page 20.
Sound Mode	See page 22.
Auto Clock Set (in analogue mode only)	Allows you to switch to digital mode and obtain the time.
Sleep Timer	See page 25.
Volume	Adjusts the volume of the headphones.

Viewing pictures from connected equipment

Switch on the connected equipment, then perform one of the following operation.

For equipment connected to the scart sockets using a fully-wired 21-pin scart lead

Start playback on the connected equipment. The picture from the connected equipment appears on the screen.

For an auto-tuned VCR (page 6)

In analogue mode, press **PROG +/-**, or the number buttons, to select the video channel.

For other connected equipment

Press **[Left]**/**[Right]** repeatedly until the correct input symbol (see below) appears on the screen.

[Left] AV 1 / [Right] AV 1, [Left] AV 2 / [Right] AV 2:	Audio/video or RGB input signal through the scart socket [Left] / [Right] 1 or 2. [Left] appears only if an RGB source has been connected.
[Left] AV 3:	Component input signal through the Y, Pb/Cb, Pr/Cr sockets [Left] / [Right] 3, and audio input signal through the L, R sockets [Left] / [Right] 3.
[Left] AV 4 / [Right] AV 5:	Digital audio/video signal is input through the HDMI IN 4/5 socket. Audio input signal is analogue only if the equipment has been connected using the DVI and audio out socket.
[Left] AV 6 / [Right] AV 6:	Video input signal through the video socket [Left] 6, and audio input signal through the L (MONO), R audio sockets [Left] 6. [Left] 6 appears only if the equipment is connected to the S video socket [Left] 6 instead of the video socket [Left] 6, and S video input signal is input through the S video socket [Left] 6.
Additional operations	
To	Do this
Return to the normal TV operation	Press DIGITAL or ANALOG .
Access the Input signal index table	Press [Enter] to access the Input signal index table. (Then, only in analogue mode, press [Left] .) To select an input source, press [Left] / [Right] , then press [Enter] .

Using MENU Functions

Navigating through menus

"MENU" allows you to enjoy various convenient features of this TV. You can easily select channels or external inputs with the remote. Also, settings for your TV can be changed easily using "MENU".

1 Press MENU to display the menu.

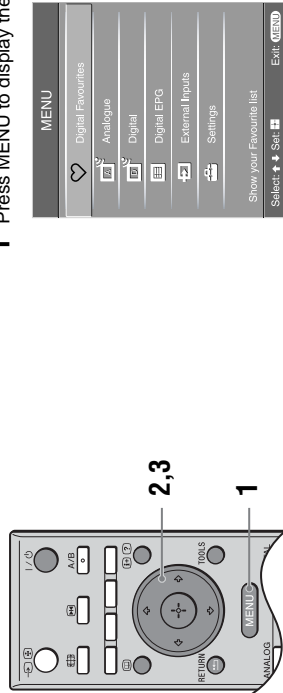

2 Press left/right arrow to select an option.

3 Press OK to confirm a selected option. To exit the menu, press MENU.

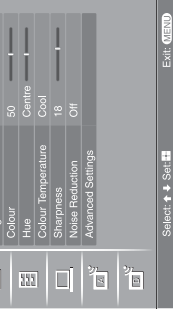

You can select the options listed below on the Picture menu. To select options in "Settings", see "Navigating through menus" (page 19).

Target Inputs

Selects whether to apply settings made in the Picture menu to all inputs, or only to the input currently being watched.

"All": Applies settings to all inputs.

"Viewing Only": Applies settings only to the current input.

Picture Mode

Selects the picture mode.

"Vivid": For enhanced picture contrast and sharpness.

"Standard": For standard picture. Recommended for home entertainment.

"Custom": Allows you to store your preferred settings.

Reset

Resets all picture settings except "Picture Mode" to the factory settings.

Backlight

Adjusts the brightness of the backlight.

Tip

"Backlight" is not available when you set "Power Saving" to "High" (page 26).

Contrast

Increases or decreases picture contrast.

Brightness

Brightens or darkens the picture.

Colour

Increases or decreases colour intensity.

Hue

Increases or decreases the green tones.

Tip

"Hue" can only be adjusted for an NTSC colour signal (e.g., U.S.A. video tapes).

Colour Temperature

Adjusts the whiteness of the picture.

"Cool": Gives the white colours a blue tint.

"Neutral": Gives the white colours a neutral tint.

"Warm1"/"Warm2": Gives the white colours a red tint. "Warm2" gives a redder tint than "Warm1".

Tip

"Warm1" and "Warm2" can only be selected when you set "Picture Mode" to "Custom".

Menu

Digital Favourites
(only in areas with digital broadcasting)

Launches the Favourite list. For details about settings, see page 17.

Analogue

(only in areas with digital broadcasting)

Returns to the last viewed analogue channel.

Digital

(only in areas with digital broadcasting)

Returns to the last viewed digital channel.

Digital EPG

(only in areas with digital broadcasting)

Launches the Digital Electronic Programme Guide (EPG). For details about settings, see page 15.

External Inputs

Selects equipment connected to your TV.

- To watch the desired external input, select the input source, then press .
- To assign a label to an external input, see page 25.

Settings

Opens the Settings menu screen where most of advanced settings and adjustments are performed. Select a menu icon, select an option and make the desired change or adjustment using , , , . For details about settings, see page 20 to 32.

Sound menu

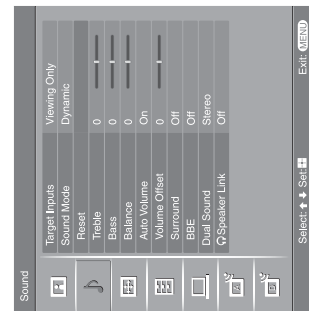

You can select the options listed below on the Sound menu. To select options in "Settings", see "Navigating through menus" (page 19).

Target Inputs

Selects whether to apply settings made in the Sound menu to all inputs, or only to the input currently being watched.
 "All": Applies settings to all inputs.
 "Viewing Only": Applies settings only to the current input.

Sound Mode

Selects the sound mode.
 "Dynamic": Enhances treble and bass.
 "Standard": For standard sound. Recommended for home entertainment.
 "Custom": Flat response. Also allows you to store your preferred settings.

Reset

Resets the sound settings except "Sound Mode", "Dual Sound" and "Speaker Link" to the factory settings.

Treble

Adjusts higher-pitched sounds.

Bass

Adjusts lower-pitched sounds.

Balance

Emphasizes left or right speaker balance.

Auto Volume

Keeps a constant volume level even when volume level gaps occur (e.g., adverts tend to be louder than programmes).

Volume Offset

Adjusts the volume level of the current input relative to other inputs, when "Target Inputs" is set to "Viewing Only".

Surround

Selects the surround mode.
 "TruSurround XT": For surround sound (for stereo programmes only).
 "Simulated Stereo": Adds a surround-like effect to mono programs.
 "Off": For normal stereo or mono reception.

BBE

Gives sound more impact by compensating for phase effects in speakers using the "BBE High Definition Sound System".

Screen menu

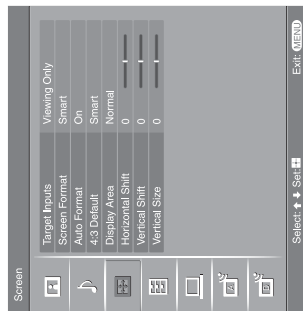

You can select the options listed below on the Screen menu. To select options in "Settings", see "Navigating through menus" (page 19).

Target Inputs

Selects whether to apply settings made in the Screen menu to all inputs, or only to the input currently being watched.
 "All": Applies settings to all inputs.
 "Viewing Only": Applies settings only to the current input.

Screen Format

For details about the screen format, see "To change the screen mode manually to suit the broadcast" (page 14).

Auto Format

Automatically changes the screen format according to the broadcast signal. To keep your setting, select "Off".

Tips

- Even if you have selected "On" or "Off" in "Auto Format", you can always modify the format of the screen by pressing **FF** repeatedly.
- "Auto Format" is available for PAL and SECAM signals only.

4:3 Default

Selects the default screen mode for use with 4:3 broadcasts.
 "Smart": Displays conventional 4:3 broadcasts with an imitation wide screen effect.
 "4:3": Displays conventional 4:3 broadcasts in the correct proportions.
 "Off": Keeps the current "Screen Format" setting when the channel or input is changed.

Tip

This option is available only if "Auto Format" is set to "On".

Display Area

Adjusts the screen area displaying the picture.
 "Normal": Displays the picture in the original size.
 "1"/"2": Enlarges the picture to hide the edge of the picture.

Horizontal Shift

Adjusts the horizontal position of the picture for each screen format.

Vertical Shift

Adjusts the vertical position of the picture when the screen format is set to Smart (50 Hz), Zoom or 14:9.

Vertical Size

Adjusts the vertical size of the picture when the screen format is set to Smart, Zoom or 14:9.

Set-up menu

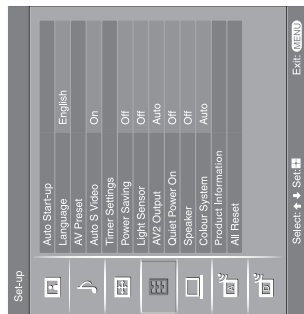

You can select the options listed below on the Set-up menu. To select options in "Settings", see "Navigating through menus" (page 19).

Auto Start-up

Starts the "first time operation menu" to select the language and country/region, and tune in all available digital and analogue channels. Usually, you do not need to do this operation because the language and country/region will have been selected and channels already tuned when the TV was first installed (page 5, 6). However, this option allows you to repeat the process (e.g., to return the TV after moving house, or to search for new channels that have been launched by broadcasters).

Language

Selects the language in which the menus are displayed.

AV Preset

Assigns a name to any equipment connected to the side and rear sockets. The name will be displayed briefly on the screen when the equipment is selected. You can skip an input source that is not connected to any equipment.

- 1 Press \leftarrow/\rightarrow to select the desired input source, then press \oplus .
- 2 Press \leftarrow/\rightarrow to select the desired option below, then press \oplus .

Equipment labels: Uses one of the preset labels to assign a name to connected equipment.

"Edit": Creates your own label. Follow steps 2 to 4 of "Programme Labels" (page 28).

"Skip": Skips an input source that is not connected to any equipment when you press \leftarrow to select the input source.

Auto S Video

Selects the input signal from S video sockets S-Video when S-Video/AV sockets are both connected.

Timer Settings

Sets the timer to turn on/off the TV.

Sleep Timer

Sets a period of time after which the TV automatically switches itself into standby mode.

When the Sleep Timer is activated, the \odot (Timer) indicator on the TV (front) lights up in orange.

Tips

- If you switch off the TV and switch it on again, "Sleep Timer" is reset to "Off".
- "TV will soon turn off by sleep timer." appears on the screen one minute before the TV switches to standby mode.

PC Settings menu

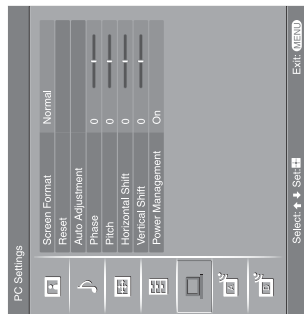

You can select the options listed below on the PC Settings menu. To select options in "Settings", see "Navigating through menus" (page 19).

Screen Format

Selects a screen mode for displaying input from your PC.

"Normal": Displays the picture in its original size.

"Full1": Enlarges the picture to fill the display area, keeping its original horizontal-to-vertical aspect ratio.

"Full2": Enlarges the picture to fill the display area.

Reset

Resets the PC settings except "Screen Format" and "Power Management" to the factory settings.

Auto Adjustment

Automatically adjusts the display position and phase of the picture when the TV receives an input signal from the connected PC.

Tip

Auto Adjustment may not work well with certain input signals. In such cases, manually adjust "Phase", "Pitch", "Horizontal Shift" and "Vertical Shift".

Phase

Adjusts the phase when the screen flickers.

Pitch

Adjusts the pitch when the picture has unwanted vertical stripes.

Horizontal Shift

Adjusts the horizontal position of the picture for each screen format.

Vertical Shift

Adjusts the vertical position of the picture for each screen format.

Power Management

Switches the TV to standby mode if no signal is received for 30 seconds.

Analogue Set-up menu (Analogue mode only)

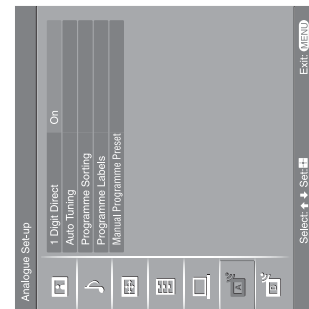

You can change/set the analogue settings using the Analogue Set-up menu. To select options in "Settings", see "Navigating through menus" (page 19).

1 Digit Direct

When "1 Digit Direct" is set to "On", you can select an analogue channel using one preset number button (0 - 9) on the remote.

Note

When "1 Digit Direct" is set to "On", you cannot select channel numbers 10 and above entering two digits using the remote.

Auto Tuning

Tunes in all the available analogue channels. Usually you do not need to do this operation because the channels are already tuned when the TV was first installed (page 5, 6). However, this option allows you to repeat the process (e.g., to retune the TV after moving house, or to search for new channels that have been launched by broadcasters).

Programme Sorting

Changes the order in which the analogue channels are stored on the TV.

- 1 Press \uparrow/\downarrow to select the channel you want to move to a new position, then press \oplus .
- 2 Press \uparrow/\downarrow to select the new position for your channel, then press \oplus .

Programme Labels

Assigns a channel name of your choice up to five letters or numbers. The name will be displayed briefly on the screen when the channel is selected. (Names for channels are usually taken automatically from Text (if available).)

- 1 Press \uparrow/\downarrow to select the channel you want to name, then press \oplus .
- 2 Press \uparrow/\downarrow to select the desired letter or number (" " for a blank space), then press \leftarrow .

If you input a wrong character

Press \leftarrow to select the wrong character. Then, press \uparrow/\downarrow to select the correct character.

To delete all the characters

- 1 Select "Reset", then press \oplus .
- 3 Repeat the procedure in step 2 until the name is complete.
- 4 Select "OK", then press \oplus .

Digital Set-up menu DV3

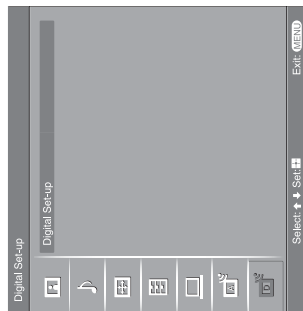

You can change/set the digital settings using the Digital Set-up menu. Select "Digital Set-up" and press \oplus to display the following menus. To select options in "Settings", see "Navigating through menus" (page 19).

Digital Tuning

Displays the "Digital Tuning" menu.

Digital Auto Tuning

Tunes in all the available digital channels.

Usually you do not need to do this operation because the channels are already tuned when the TV was first installed (page 6). However, this option allows you to repeat the process (e.g., to retune the TV after moving house, or to search for new channels that have been launched by broadcasters).

Programme List Edit

Removes any unwanted digital channels stored on the TV, and changes the order of the digital channels stored on the TV.

- 1 Press \uparrow/\downarrow to select the channel you want to remove or move to a new position.
- If you know the programme number (frequency)**
Press the number buttons to enter the three-digit programme number of the broadcast you want.
- 2 Remove or change the order of the digital channels as follows:

To remove the digital channel

Press \oplus . A message that confirms whether the selected digital channel is to be deleted appears. Press \leftarrow to select "Yes", then press \oplus .

To change the order of the digital channels

Press \leftarrow , then press \uparrow/\downarrow to select the new position for the channel and press \leftarrow . Repeat the procedure in steps 1 and 2 to move other channels if required.

- 3 Press RETURN.

Digital Manual Tuning

Tunes the digital channels manually.

- 1 Press the number button to select the channel number you want to manually tune, then press \uparrow/\downarrow to tune the channel.
- 2 When the available channels are found, press \uparrow/\downarrow to select the channel you want to store, then press \oplus .
- 3 Press \uparrow/\downarrow to select the programme number where you want to store the new channel, then press \oplus .

Repeat the procedure above to tune other channels manually.

Using Optional Equipment

Connecting optional equipment

You can connect a wide range of optional equipment to your TV. Connecting cables are not supplied.

Connecting to the TV (side)

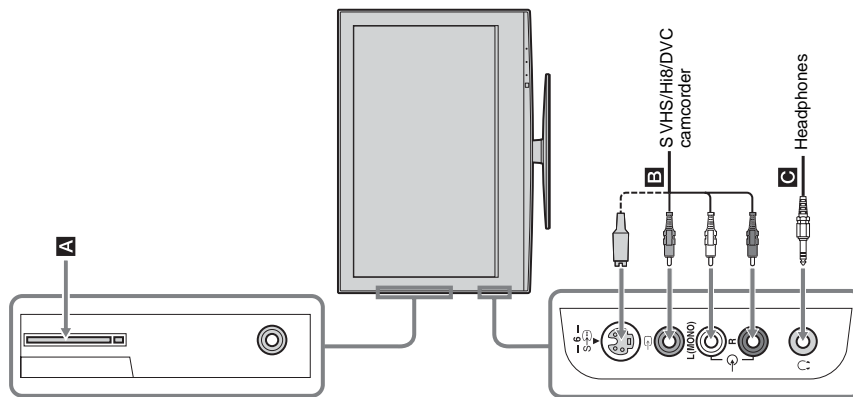

To connect

Conditional Access Module (CAM) A To use Pay Per View services. For details, refer to the instruction manual supplied with your CAM. To use the CAM, remove the rubber cover from the CAM slot. Switch off the TV when inserting your CAM into the CAM slot. When you do not use the CAM, we recommend that you replace the cover on the CAM slot.

Note

CAM is not supported in all countries. Please check with your authorized dealer.

SVHS/Hi8/DVC camcorder B

Connect to the S video socket \rightarrow 6, the video socket \rightarrow 6, and the audio sockets \rightarrow 6. To avoid picture noise, do not connect the camcorder to the video socket \rightarrow 6 and the S video socket \rightarrow 6 at the same time. If you connect mono equipment, connect to the L socket \rightarrow 6.

Headphones C

Connect to the \rightarrow 6 socket to listen to sound from the TV on headphones.

Connecting to the TV (rear)

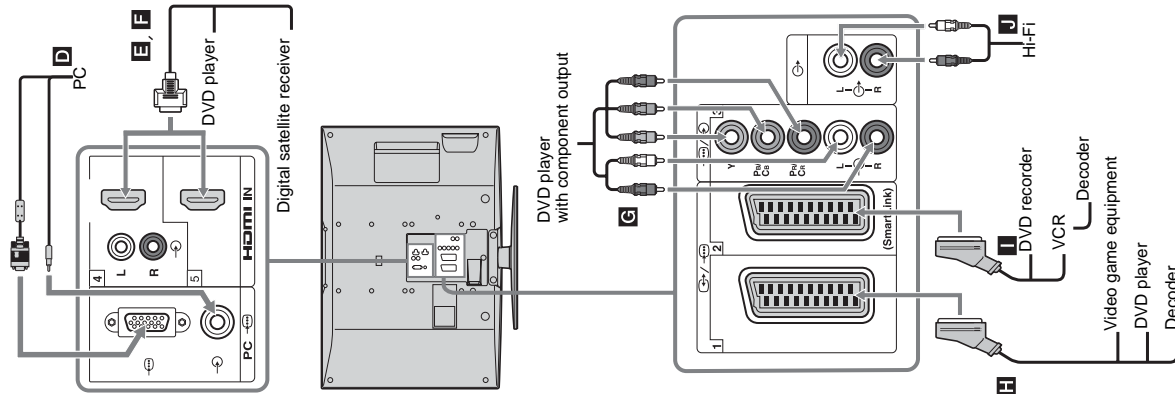

To connect

PC D Connect to the PC \rightarrow 4 socket. It is recommended to use a PC cable with ferrites.

Digital satellite receiver or DVD player E, F Connect to the HDMI IN 4 or 5 socket if the equipment has a HDMI socket. The digital video and audio signals are input from the equipment. If the equipment has a DVI socket, connect the DVI socket to the HDMI IN 4 socket through a DVI - HDMI adaptor interface (not supplied), and connect the equipment's audio out sockets to the audio in HDMI IN 4 sockets.

Notes

- The HDMI sockets only support the following video inputs: 480i, 480p, 576i, 576p, 720p and 1080i. To connect a PC, please use the PC \rightarrow 4 socket.
- Be sure to use only an HDMI cable that bears the HDMI logo.

DVD player with component output G Connect to the component sockets and the audio sockets \rightarrow 3.

Video game player or decoder H Connect to the scart socket \rightarrow 1. When you connect the decoder, the scrambled signal from the TV tuner is output to the decoder, then the unscrambled signal is output from the decoder.

DVD recorder or SmartLink I Connect to the scart socket \rightarrow 2. SmartLink is a direct link between the TV and a VCR/DVD recorder.

Hi-Fi audio equipment J Connect to the audio output sockets \rightarrow to listen to the sound from the TV on Hi-Fi audio equipment.

Continued

Additional Information

Specifications

Display Unit

Power Requirements:
220-240 V AC, 50 Hz
Screen Size:
KDL-46S2510/KDL-46S2530:
46 inches (Approx. 116.9 cm measured diagonally)
KDL-40S2510/KDL-40S2530:
40 inches (Approx. 101.6 cm measured diagonally)
KDL-32S2510/KDL-32S2520/KDL-32S2530:
32 inches (Approx. 80.1 cm measured diagonally)
Display Resolution:
1,366 dots (horizontal) × 768 lines (vertical)

Power Consumption:
KDL-46S2510/KDL-46S2530: 220 W
KDL-40S2510/KDL-40S2530: 180 W
KDL-32S2510/KDL-32S2520/KDL-32S2530: 125 W
Standby Power Consumption:
0.3 W
Dimensions (w × h × d):
KDL-46S2510/KDL-46S2530:
Approx. 1,120 × 805 × 334 mm (with stand)
Approx. 1,120 × 755 × 116 mm (without stand)
KDL-40S2510/KDL-40S2530:
Approx. 988 × 716 × 334 mm (with stand)
Approx. 988 × 664 × 103 mm (without stand)
KDL-32S2510/KDL-32S2520/KDL-32S2530:
Approx. 792 × 593 × 219 mm (with stand)
Approx. 792 × 546 × 99 mm (without stand)

Mass:
KDL-46S2510/KDL-46S2530:
Approx. 34 kg (with stand)
Approx. 28 kg (without stand)
KDL-40S2510/KDL-40S2530:
Approx. 27 kg (with stand)
Approx. 21 kg (without stand)
KDL-32S2510/KDL-32S2520/KDL-32S2530:
Approx. 17 kg (with stand)
Approx. 15 kg (without stand)

Panel System
LCD (Liquid Crystal Display) Panel
TV System
Analogue: Depending on your country/region selection:
B/G/H, D/K, L, I
Digital: DVB-T
Colour/Video System
Analogue: PAL, SECAM
NTSC 3.58, 4.43 (only Video In)
Digital: MPEG-2 MP@ML
Aerial
75 ohm external terminal for VHF/UHF

Sound Output

10 W + 10 W

Supplied Accessories

Refer to "I: Checking the accessories" on page 4.

Optional Accessories

- Wall-Mount Bracket
SU-WL51 (for KDL-46S2510/KDL-46S2530)
KDL-40S2510/KDL-40S2530)
SU-WL31 (for KDL-32S2510/KDL-32S2520/
KDL-32S2530)

Design and specifications are subject to change without notice.

PC Input Signal Reference Chart



Signals	Horizontal (Pixel)	Vertical (Line)	Horizontal frequency (kHz)	Vertical frequency (Hz)	Standard
VGA	640	480	31.5	60	VGA
	640	480	37.5	75	VESA
	720	400	31.5	70	VGA-T
SVGA	800	600	37.9	60	VESA Guidelines
	800	600	46.9	75	VESA
XGA	1024	768	48.4	60	VESA Guidelines
	1024	768	56.5	70	VESA
	1024	768	60	75	VESA
WXGA	1280	768	47.4	60	VESA
	1280	768	47.8	60	VESA
	1360	768	47.7	60	VESA

- This TV's PC input does not support Sync on Green or Composite Sync.
- This TV's PC input does not support interlaced signals.
- For the best picture quality, it is recommended to use signals with a 60 Hz vertical frequency from a personal computer. In plug and play, signals with a 60 Hz vertical frequency will be selected automatically.

Channel Coverage







Analogue: VHF: E2-E12
UHF: E21-E69
CATV: S1-S20
HYPER: S21-S41
D/K: R1-R12, R21-R69
L: F2-F10, B-Q, F21-F69
I: UHF B21-B69
Digital: VHF/UHF

Terminals

 21-pin SCART connector (CENELEC standard) including audio/video input, RGB input, and TV audio/video output.
 21-pin Smart connector (CENELEC standard) including audio/video input, RGB input, selectable audio/video output, and SmartLink interface.

 Supported formats: 1080i, 720p, 576p, 576i, 480p, 480i
Y: 1 Vp-p, 75 ohms, 0.3V negative sync
Pb/Cb: 0.7 Vp-p, 75 ohms
Pr/Cr: 0.7 Vp-p, 75 ohms

 3
Audio input (phono jacks)
500 mVrms
Impedance: 47 kilo ohms
HDMI IN 4, 5
Video: 1080i, 720p, 576p, 576i, 480p, 480i
Audio: Two channel linear PCM
32, 44.1 and 48 kHz, 16, 20 and 24 bits
Analogue audio (phono jacks):
500 mVrms, Impedance 47 kilohms
(HDMI IN 4 only)

 6 S video input (4-pin mini DIN)
 6 Video input (phono jack)
 6 Audio input (phono jacks)
 PC → PC Input (Left/Right) (phono jacks)
PC → PC Input (15 Dsub) (see page 37)
G: 0.7 Vp-p, 75 ohms, non Sync on Green
B: 0.7 Vp-p, 75 ohms, non Sync on Green
R: 0.7 Vp-p, 75 ohms, non Sync on Green
HD: 1.5 Vp-p
VD: 1.5 Vp-p
→ PC audio input (minijack)
 Headphones jack
 CAM (Conditional Access Module) slot

Troubleshooting

Check whether the  (standby) indicator is flashing in red.

When it is flashing

The self-diagnosis function is activated.

1 Measure how long the  (standby) indicator flashes and stops flashing.

For example, the indicator flashes for two seconds, stops flashing for one second, and flashes for two seconds.

2 Press  on the TV (top side) to switch it off, disconnect the mains lead, and inform your dealer or Sony service centre of how the indicator flashes (duration and interval).



When it is not flashing

- 1 Check the items in the tables below.
- 2 If the problem still persists, have your TV serviced by qualified service personnel.



Picture

Problem

No picture (screen is dark) and no sound

- Check the aerial connection.
- Connect the TV to the mains, and press  on the TV (top side).
- If the  (standby) indicator lights up in red, press .

No picture or no menu information from equipment connected to the smart connector

- Check that the optional equipment is on and press /  repeatedly until the correct input symbol is displayed on the screen.
- Check the connection between the optional equipment and the TV.

Double images or ghosting

- Check aerial/cable connections.
- Check the aerial location and direction.

Only snow and noise appear on the screen

- Check if the aerial is broken or bent.
- Check if the aerial has reached the end of its serviceable life (three to five years in normal use, one to two years at the seaside).

Distorted picture (dotted lines or stripes)

- Keep the TV away from electrical noise sources such as cars, motorcycles, hair-dryers or optical equipment.
- When installing optional equipment, leave some space between the optional equipment and the TV.
- Make sure that the aerial is connected using the supplied coaxial cable.
- Keep the aerial cable away from other connecting cables.

Picture noise when viewing a TV channel

- Select "Manual Programme Preset" in the "Analogue Set-up" menu and adjust "AFT" (Automatic Fine Tuning) to obtain better picture reception (page 29).

Some tiny black points and/or bright points on the screen

- The picture of a display unit is composed of pixels. Tiny black points and/or bright points (pixels) on the screen do not indicate a malfunction.

No colour on programmes

- Select "Reset" in the "Picture" menu to return to the factory settings (page 20).



No colour or irregular colour when viewing a signal from the Y, Pb/Cb, Pr/O

- Check the connection of the Y, Pb/Cb, Pr/Cr jacks of  3.
- Make sure that the Y, Pb/Cb, Pr/Cr jacks of  3 are firmly seated in their respective sockets.

Sound

Problem Cause/Remedy

No sound, but good picture

- Press  +/- or  (Mute).
- Check that "Speaker" is set to "On" in the "Set-up" menu (page 26).

Noisy sound

- See the "Picture noise" causes/remedies on page 38.

Channels

Problem Cause/Remedy

The desired channel cannot be selected

- Switch between digital and analogue mode and select the desired digital/analogue channel.

Some channels are blank

- Scrambled/Subscription only channel. Subscribe to the Pay Per View service.
- Channel is used only for data (no picture or sound).
- Contact the broadcaster for transmission details.

Digital channel is not displayed

- Contact a local installer to find out if digital transmissions are provided in your area.
- Upgrade to a higher gain aerial.

General

Problem Cause/Remedy

The TV turns off automatically (the TV enters standby mode)

- Check if the "Sleep Timer" is activated, or confirm the "Duration" setting of "On Timer" (page 25).
- If no signal is received and no operation is performed in the TV mode for 10 minutes, the TV automatically switches to standby mode.

The TV turns on automatically

- Check if the "On Timer" is activated (page 26).

Some input sources cannot be selected

- Select "AV Preset" in the "Set-up" menu and cancel "Skip" of the input source (page 25).

The remote does not function

- Replace the batteries.

SECTION 2 DISASSEMBLY

2-1. REAR COVER REMOVAL

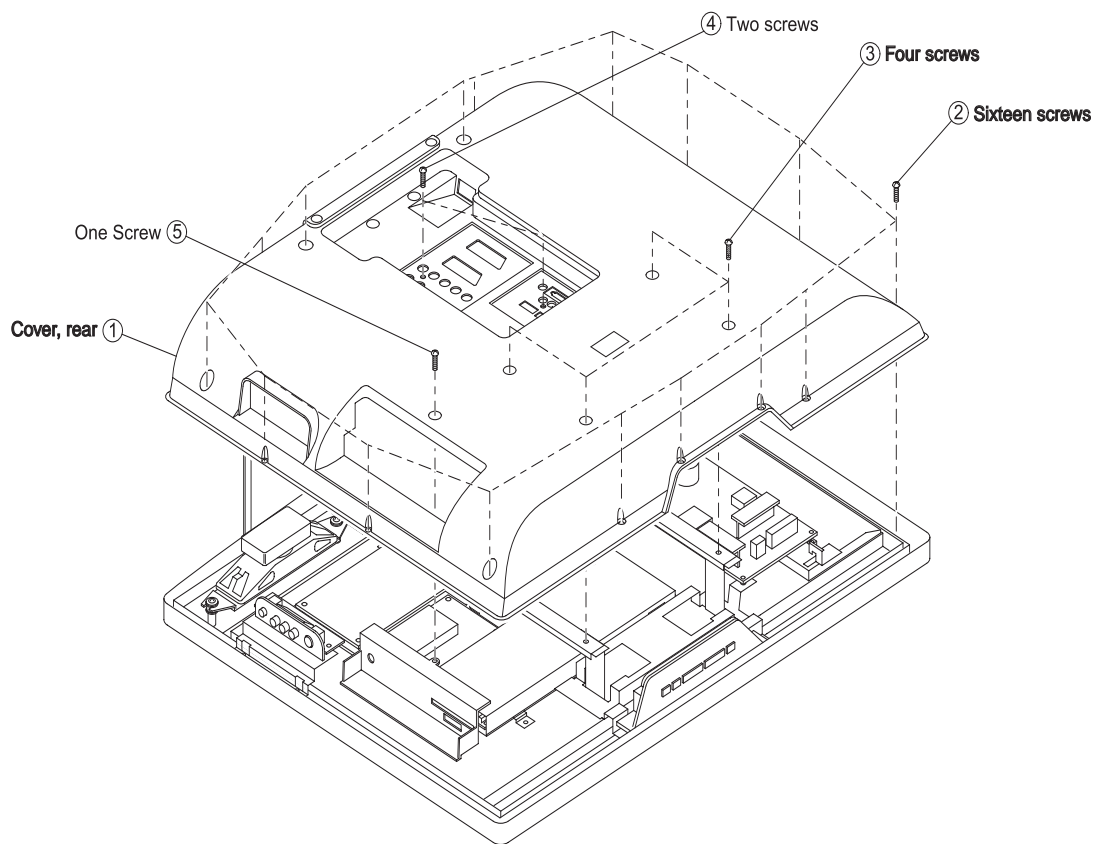

2-2. STAND REMOVAL

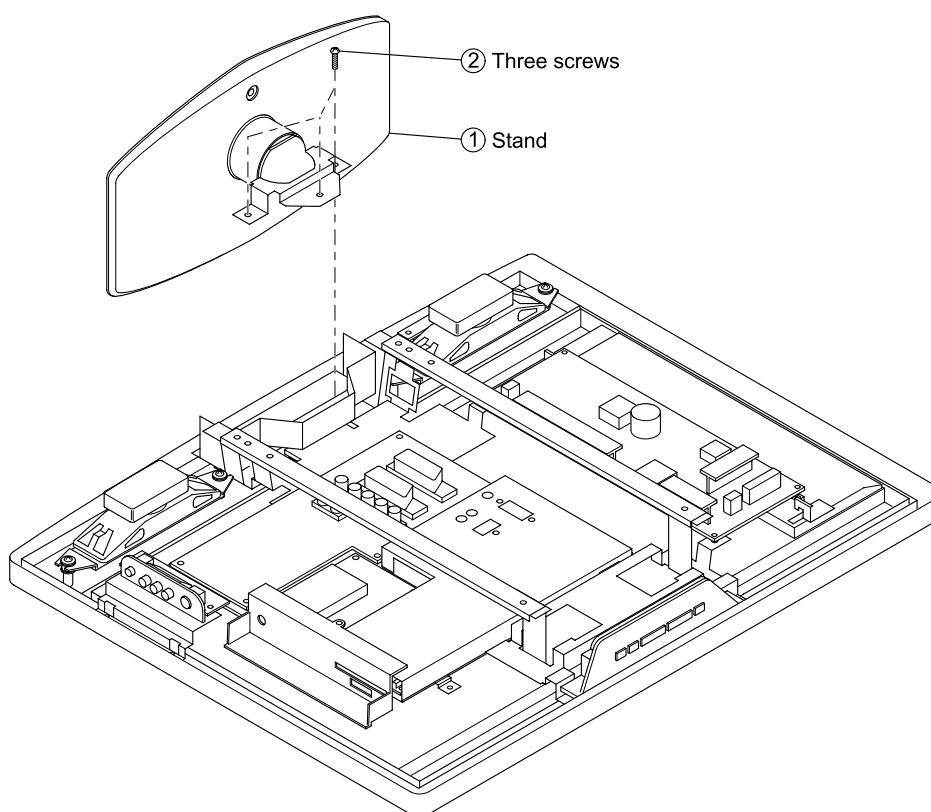

2-3. VESA BRACKET REMOVAL

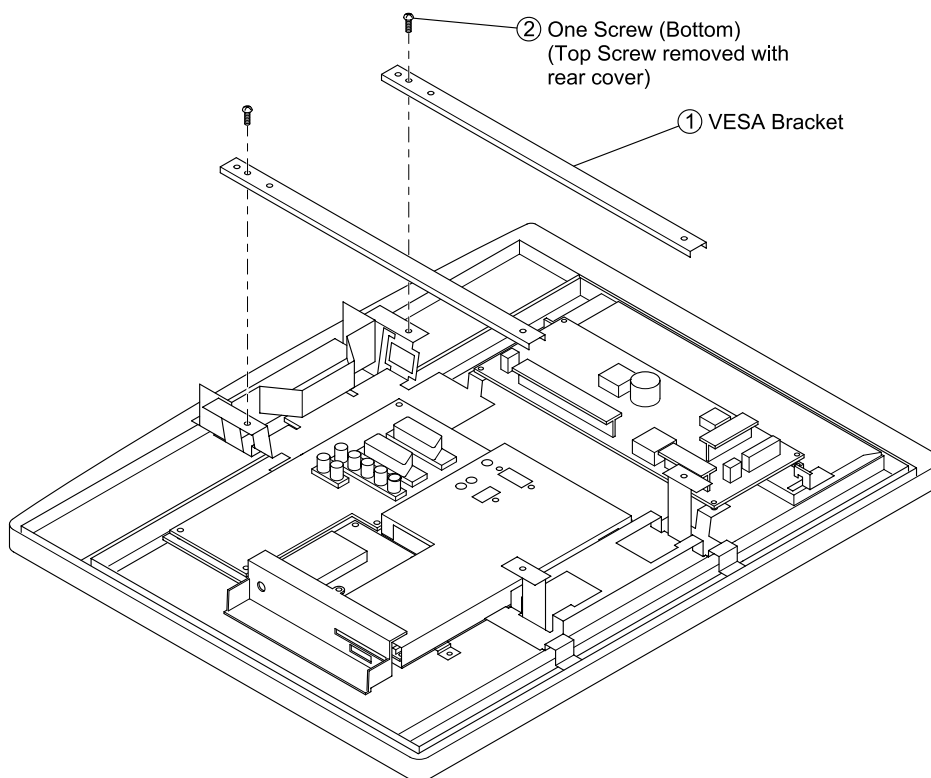

2-4. AC INLET REMOVAL

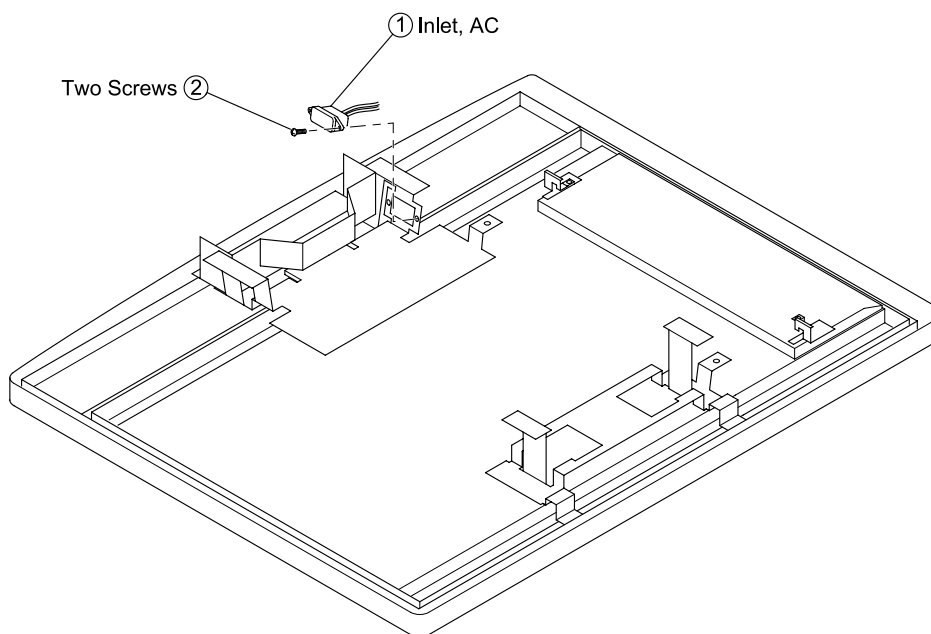

2-5. SPEAKER REMOVAL

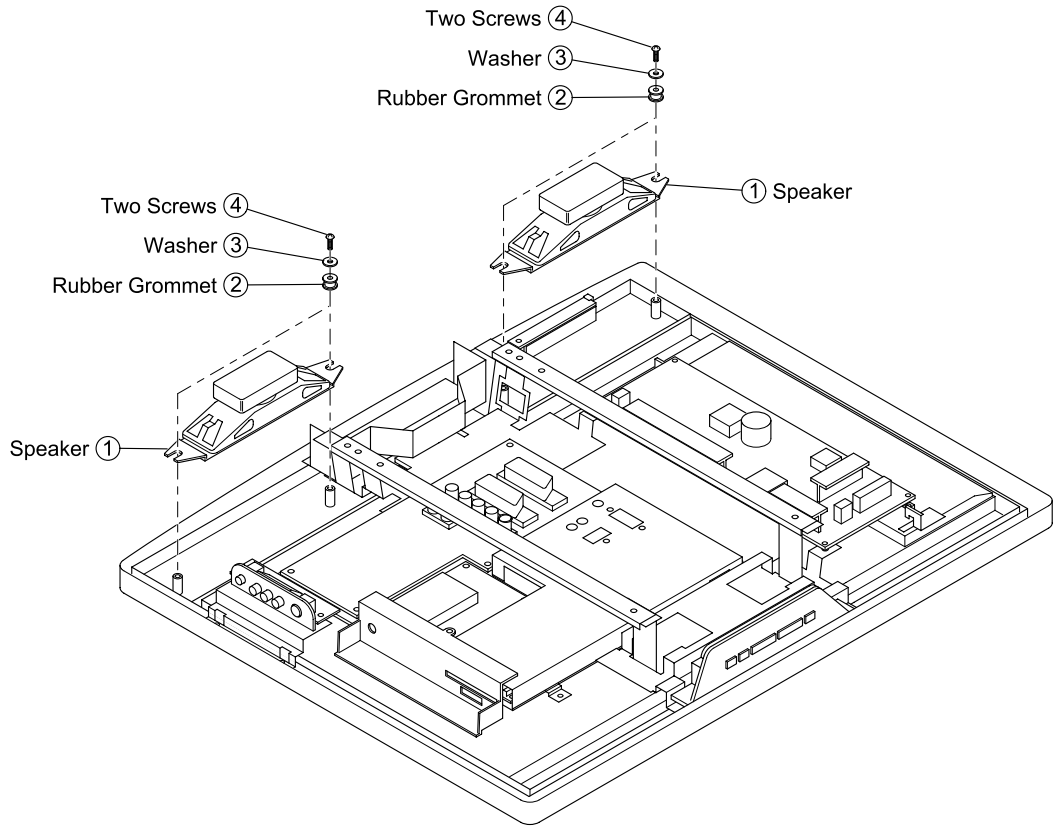

2-6. AE and TUE BOARD REMOVAL

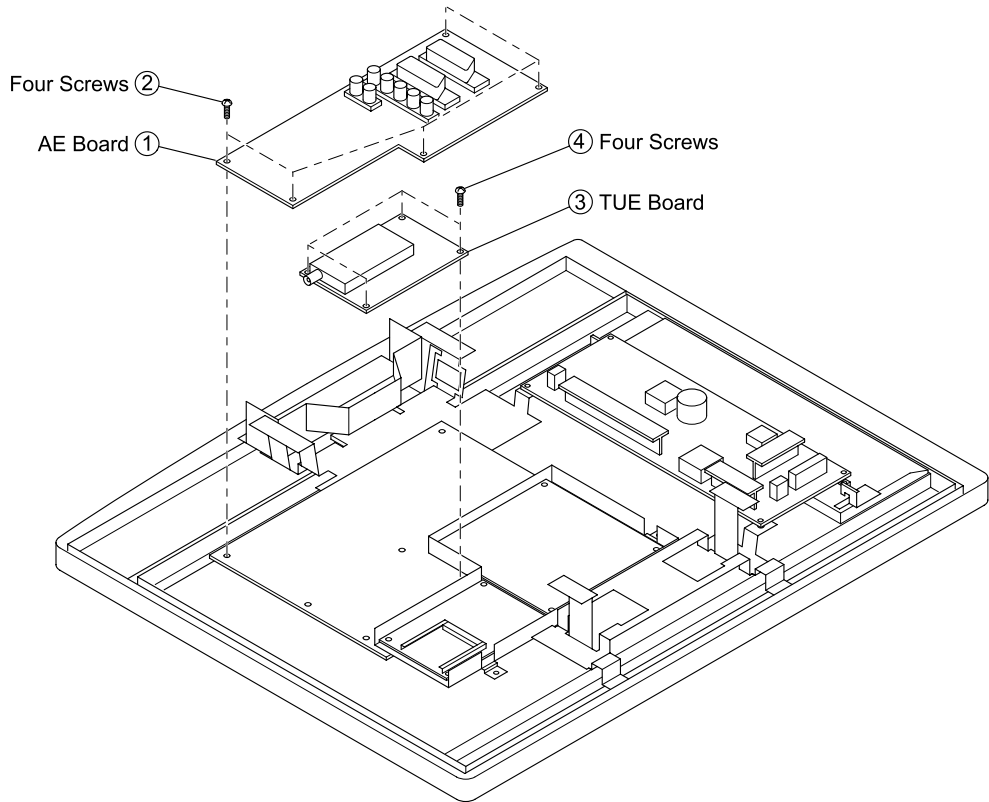

2-7. B2H and FEE BOARD REMOVAL

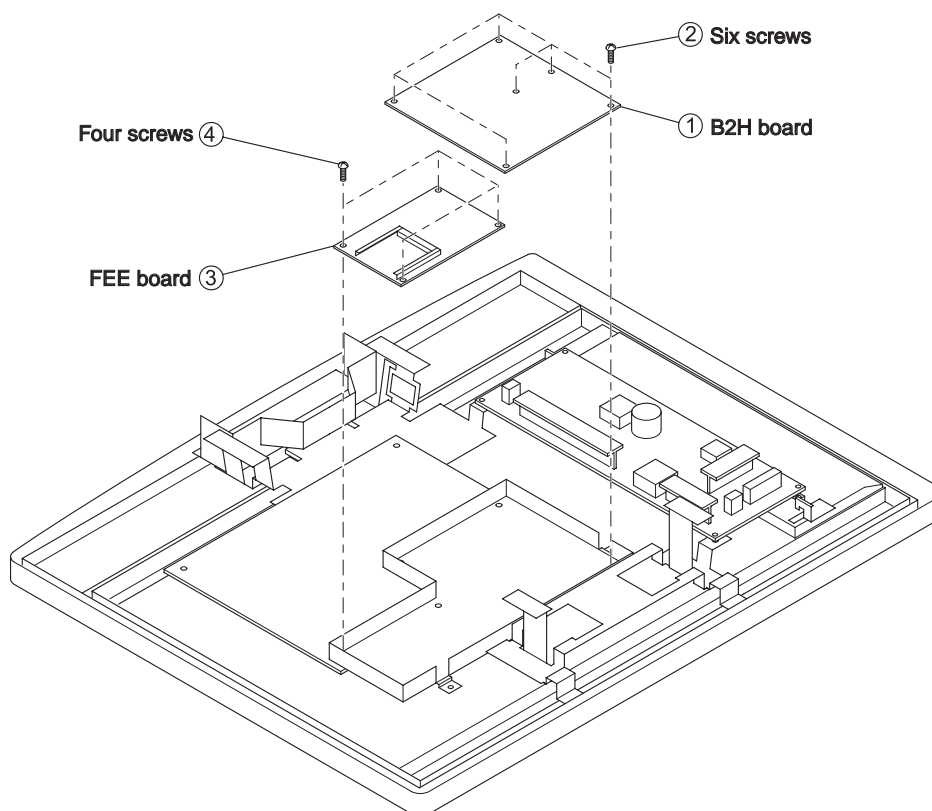

2-8. G1 or G2A BOARD REMOVAL

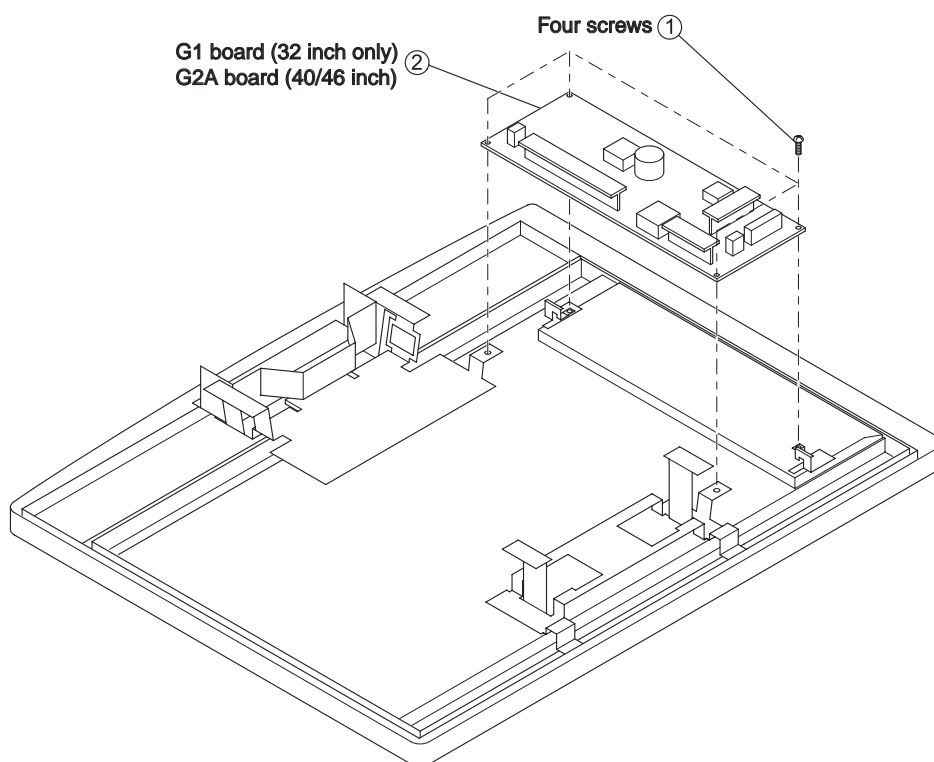

2-9. H1E BOARD REMOVAL

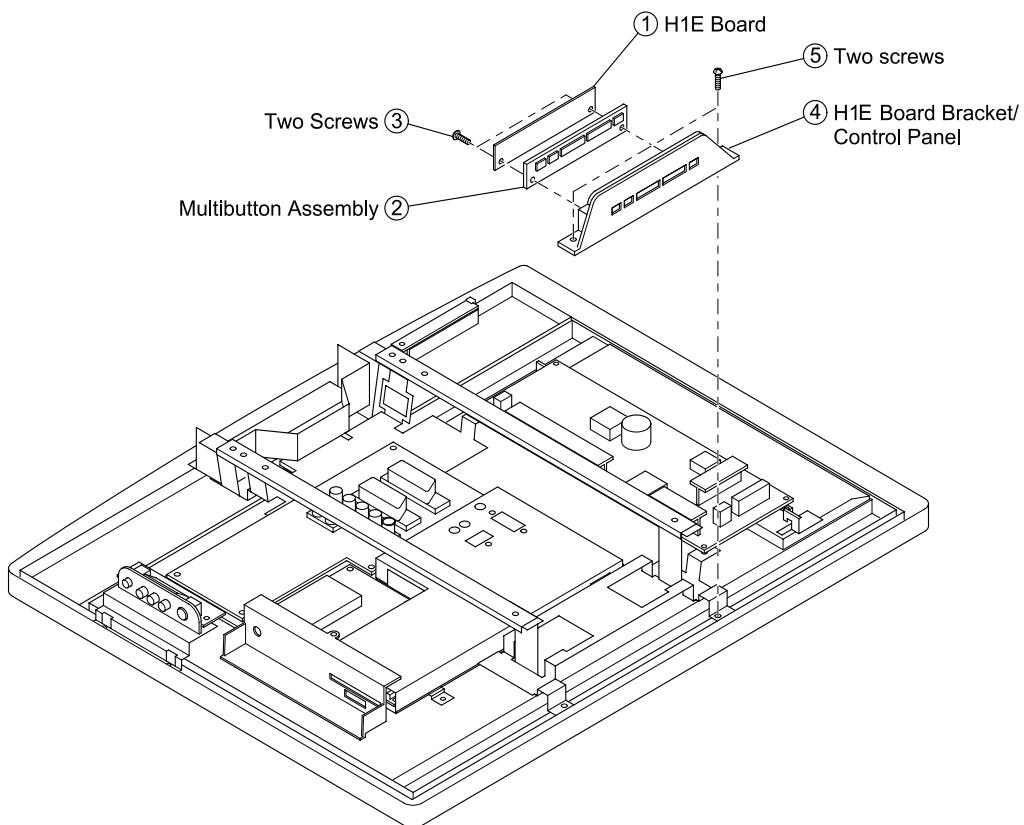

2-10. H2E or H46E BOARD REMOVAL

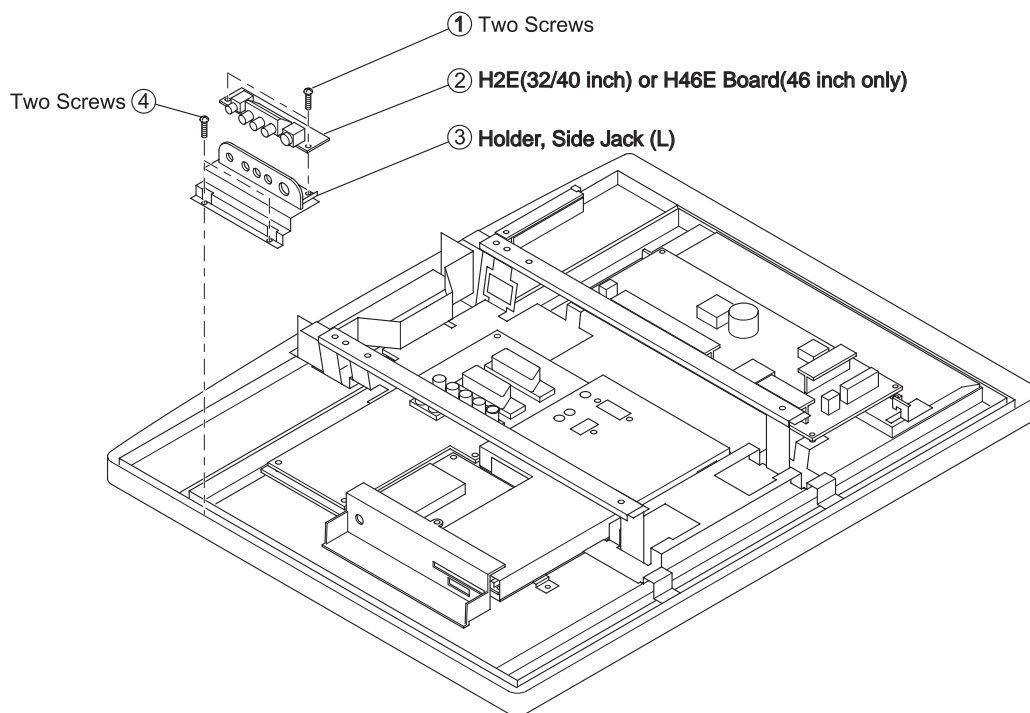

2-11. H3E BOARD REMOVAL

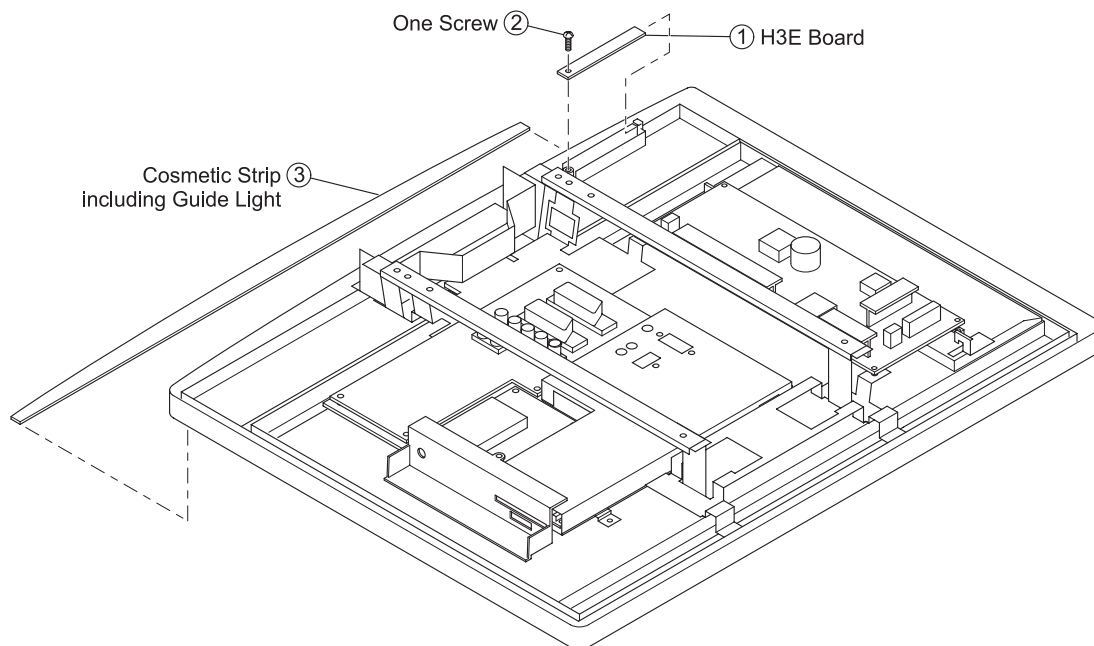

2-12. LCD PANEL REMOVAL

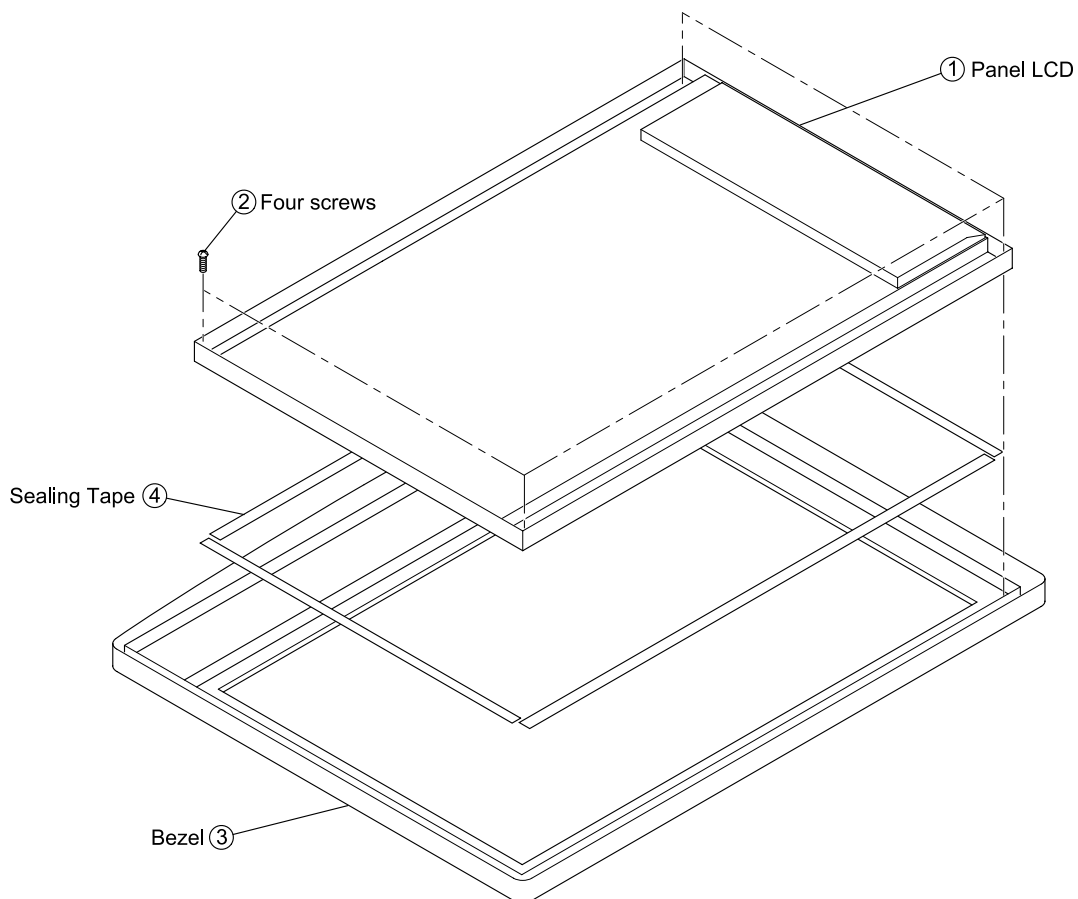

SECTION 3 SET-UP ADJUSTMENTS

3-1. How to enter Service Mode

Service adjustments to this model can be performed using the supplied remote Commander RM-ED008.

1. Turn on the power to the TV set and enter into the stand-by mode.
2. Press the following sequence of buttons on the Remote Commander.

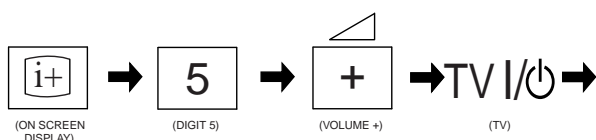

3. The following menu will then appear on the screen.

Analogue	
MAIN VER.	0800
H PACK VER.	1006
S PACK VER.	1009
CHECK SUM	C9A9
NVM VER.	0327
EMMA VER.	2.5.15
STARTER	0.0.13
ETI	0h 42m

4. Move to the relevant command using the up or down arrow buttons on the remote commander.
5. Press the right arrow button to enter into the required menu item.
6. Press the 'Menu' button on the remote commander to quit the Service Mode when all adjustments have been completed.

Note :

- After carrying out the service adjustments, to prevent the customer accessing the 'Service Menu' switch the TV set OFF and then ON.

3-2. Signal Level Adjustment

3-2-1. Set up of AD calibration¹ adjustment for terrestrial analog.

The following adjustments are done via ECS.

1. Send ECS_ADJUST_LEVEL_SETTING_INIT command.
2. Ensure noise reduction NR=3 (High), GAMMA_EN=0, P4_CVD2_85=0.
3. Set the following registration items.

Screen Size	32"	40"	46"
TARGET_Y_RF(PAL)	165	165	165
ADJ_COLOR_Y_ATT(PAL)	128	128	128
ADJ_COLOR_PAL(PAL)	3	3	3

3-2-2. Y signal calibration¹ adjustment for terrestrial analog.

1. Input PAL colour bar 75% Y, 75% C via terrestrial input.

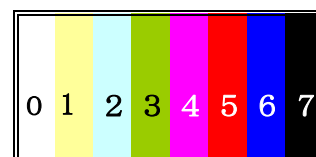

2. Send ECS_ADJUST_TCD3_CONT_RF command.
3. Read the value of S-REG:APL_LUMA via ECS. Confirming that the value is within spec of the table below.

AD-Adjust RF Spec	Spec.
Reference register name	
S-REG: APL_LUMA	TARGET_Y_RF±2

3-2-3. Set up of C signal calibration¹ adjustment for terrestrial analog.

1. Input PAL colour bar 75% Y, 75% C via terrestrial input.
2. Send ECS_ADJUST_LEVEL_SETTING_INIT command.
3. Ensure noise reduction NR=3 (High), GAMMA_EN=0, P4_CVD2_85=0.

3-2-4.C signal calibration1 adjustment for terrestrial analog.

1. Send ECS_ADJUST_TCD3_HUE_RF command.
2. Read S-REG: READ_BACK_B00 via ECS. (READ_AREA=0).
3. Read S-REG: READ_BACK_B01 via ECS. (READ_AREA=6).
4. Confirm that 8 bits of MSB of item number 2) and 3) are within spec of the table below.

Reference Item	Spec.
READ_BACK_B0*difference value	±2

5. Switch the TV set OFF and then ON again to retain adjustment values.

3-2-5.Set up of AD calibration1 adjustment for video.

1. Send ECS_ADJUST_LEVEL_SETTING_INIT command.
2. Ensure noise reduction NR=1 (Low), GAMMA_EN=0, P4_CVD2_85=0.
3. Set the following registration items.

Screen Size	32"	40"	46"
TARGET_Y_RF(PAL)	165	165	165
ADJ_COLOR_Y_ATT(PAL)	128	128	128
ADJ_COLOR_PAL(PAL)	3	3	3

3-2-6.Y signal calibration1 adjustment for video.

1. Input PAL colour bar 75%Y, 75%C via AV1 input.



2. Send ECS_ADJUST_TCD3_CONT_V command.
3. Read the value of S-REG:APL_LUMA via ECS. Confirming that the value is within spec of the table below.

AD-Adjust Video Spec	Spec.
Reference register name	
S-REG: APL_LUMA	TARGET_Y_V±2

3-2-7.Set up of C signal calibration1 adjustment for video.

1. Input PAL colour bar 75%Y, 75%C via AV1 input.
2. Send ECS_ADJUST_LEVEL_SETTING_INIT command.
3. Ensure noise reduction NR=1 (Low), GAMMA_EN=0, P4_CVD2_85=0.
4. Set the following registration items.

Screen Size	32"	40"	46"
ADJ_COLOR_Y_ATT(PAL)	128	128	128
ADJ_COLOR_PAL(PAL)	3	3	3

3-2-8. C signal calibration1 adjustment for video.

1. Send ECS_ADJUST_TCD3_HUE_V command.
2. Read S-REG: READ_BACK_B00 via ECS. (READ_AREA=0).
3. Read S-REG: READ_BACK_B01 via ECS. (READ_AREA=6).
4. Confirm that 8 bits of MSB of item number 2) and 3) are within spec of the table below.

Reference Item	Spec.
READ_BACK_B0*difference value	±2

5. Read S-REG: TCD3_SATURATION via ECS.
6. Switch the TV set OFF and then ON again to retain adjustment values.

3-2-9.Set up of AD calibration2 adjustment for video.

1. Send ECS_ADJUST_LEVEL_SETTING_INIT command.
2. Ensure noise reduction NR=1 (Low), GAMMA_EN=0, P4_CVD2_85=0.
3. Set the following registration items.

Screen Size	32"	40"	46"
TARGET_Y_V(SECAM)	165	165	165
ADJ_COLOR_Y_ATT(SECAM)	128	128	128
ADJ_COLOR_PAL(SECAM)	2	2	2

3-2-10. Y signal calibration2 adjustment for video.

1. Input SECAM colour bar 75%Y, 75%C via AV1 input.

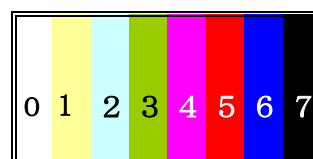

- Send ECS_ADJUST_TCD3_CONT_V command.
- Read the value of S-REG:APL_LUMA via ECS. Confirming that the value is within spec of the table below.

AD-Adjust Video Spec	Spec.
Reference register name	
S-REG: APL_LUMA	TARGET_Y_V±2

3-2-11. Set up of C signal calibration2 adjustment for video.

- Input SECAM colour bar 75% Y, 75% C via AV1 input.
- Send ECS_ADJUST_LEVEL_SETTING_INIT command.
- Ensure noise reduction NR=1 (Low), GAMMA_EN=0, P4_CVD2_85=0.
- Set the following registration items.

Screen Size	32"	40"	46"
ADJ_COLOR_Y_ATT(SECAM)	128	128	128
ADJ_COLOR_PAL(SECAM)	2	2	2

3-2-12. C signal calibration2 adjustment for video.

- Send ECS_ADJUST_TCD3_HUE_V command.
- Read S-REG: READ_BACK_B00 via ECS. (READ_AREA=0).
- Read S-REG: READ_BACK_B01 via ECS. (READ_AREA=6).
- Confirm that 8 bits of MSB of item number 2) and 3) are within spec of the table below.

Reference Item	Spec.
READ_BACK_B0*difference value	±2

- Read S-REG: TCD3_SATURATION via ECS.
- Switch the TV set OFF and then ON again to retain adjustment values.

3-3. Gamma Adjustment

The following adjustments are done via ECS.

Note: Before Gamma adjustment can begin the set needs 1 hour aging.

3-3-1. Set up mode for Gamma Adjustment

- Send ECS_ADJUST_LEVEL_SETTING_INIT command.
- Ensure COL_MATRIX_INDEX=15.
- Ensure G_GAMMA_IDX_OFST=15.
- Ensure DYNAMIC_EN=0.
- Ensure U_BRT_OFFSET=128.
- Ensure P1_D_P_26=0.
- Ensure P1_D_P_28=0.

3-3-2. Set up Trident internal SG and brightness measurement

- Ensure TEST_PATTEN_ON=1.
- Ensure TEST_G_LEVEL=204.
- Measure brightness A.
- Ensure TEST_G_LEVEL=102.
- Measure brightness B.
- Set up G_GAMMA_OFST_01=brightness B/brightness A*10000. The result is written to G_GAMMA_OFST_01.
- Send Gamma_Tbl_Search_1 command.
- Ensure TEST_G_LEVEL=153.
- Measure brightness C.
- Set up G_GAMMA_OFST_02=brightness C/brightness A*10000. The result is written to G_GAMMA_OFST_02.
- Send Gamma_Tbl_Search_2 command.
- Save set up value in NVM in register G_GAM_IDX_OFST.

3-4. White Balance Adjustment

The following adjustments are done via ECS.

3-4-1. Set up mode for White Balance Adjustment

- Send ECS_ADJUST_LEVEL_SETTING_INIT command.
- Ensure COL_MATRIX_INDEX=15.
- Ensure DYNAMIC_EN=0.
- Ensure U_BRT_OFFSET=128.
- Ensure P1_D_P_26=0.
- Ensure P1_D_P_28=0.

3-4-2. White Balance of Colour Temperature "Cool"

- Set up COLOR_TEMP=0.
- Set up R_GAMMA_OFST_01=128.
- R_GAMMA_OFST_02=128
R_GAMMA_OFST_03=128
R_GAMMA_OFST_04=128
R_GAMMA_OFST_05=128
R_GAMMA_OFST_06=128
R_GAMMA_OFST_07=128
B_GAMMA_OFST_01=128
B_GAMMA_OFST_02=128
B_GAMMA_OFST_03=128
B_GAMMA_OFST_04=128
B_GAMMA_OFST_05=128
B_GAMMA_OFST_06=128
B_GAMMA_OFST_07=128
- Set up "Wait".
- Set up TEST_R_LEVEL=204.
- Set up TEST_G_LEVEL=204.
- Set up TEST_B_LEVEL=204.
- Adjust R_GAMMA_OFST_05 and B_GAMMA_OFST_05 chroma values so that they are within tolerance in the table below.

	X	Y	Tolerance
32"	0.2733	0.2792	0.5JND
40"	0.2702	0.2675	0.5JND
46"	0.2738	0.2679	0.5JND

9. Set up TEST_R_LEVEL=153.
10. Set up TEST_G_LEVEL=153.
11. Set up TEST_B_LEVEL=153.
12. Adjust R_GAMMA_OFST_04 and B_GAMMA_OFST_04 chroma values so that they are within tolerance in the table below.

	X	Y	Tolerance
32"	0.2733	0.2792	0.7JND
40"	0.2702	0.2675	0.7JND
46"	0.2738	0.2679	0.7JND

13. Set up TEST_R_LEVEL=102.
14. Set up TEST_G_LEVEL=102.
15. Set up TEST_B_LEVEL=102.
16. Adjust R_GAMMA_OFST_03 and B_GAMMA_OFST_03 chroma values so that they are within tolerance in the table below.

	X	Y	Tolerance
32"	0.2733	0.2792	1JND
40"	0.2702	0.2675	1JND
46"	0.2738	0.2679	1JND

17. Set up TEST_R_LEVEL=76.
18. Set up TEST_G_LEVEL=76.
19. Set up TEST_B_LEVEL=76.
20. Adjust R_GAMMA_OFST_02 and B_GAMMA_OFST_02 chroma values so that they are within tolerance in the table below.

	X	Y	Tolerance
32"	0.2733	0.2792	1JND
40"	0.2702	0.2675	1JND
46"	0.2738	0.2679	1JND

21. Set up TEST_R_LEVEL=51.
22. Set up TEST_G_LEVEL=51.
23. Set up TEST_B_LEVEL=51.
24. Adjust R_GAMMA_OFST_01 and B_GAMMA_OFST_01 chroma values so that they are within tolerance in the table below.

	X	Y	Tolerance
32"	0.2733	0.2792	1JND
40"	0.2702	0.2675	1JND
46"	0.2738	0.2679	1JND

25. The values of R_GAMMA_OFST_06 and 07 and B_GAMMA_OFST_06, and 07 are determined by the following conditions.

- a). Adjustment value of B_GAMMA_OFST_05>180 and Adjustment value of R_GAMMA_OFST_05>128.

- $B(R)_GAMMA_OFST_06 = B(R)_GAMMA_OFST_05 - \{B(R)_GAMMA_OFST_05 - B(R)_GAMMA_OFST_04\} / 2.$
- $B(R)_GAMMA_OFST_07 = 128.$

- b). Adjustment value of R_GAMMA_OFST_05=<128.

- $R_GAMMA_OFST_06 = R_GAMMA_OFST_07 = R_GAMMA_OFST_04.$

- c). Adjustment value of B_GAMMA_OFST_05=<180.

- $B(R)_GAMMA_OFST_06 = B(R)_GAMMA_OFST_07 = B(R)_GAMMA_OFST_05.$

26. Send WB_SAVE command.

3-4-3. White Balance of Colour Temperature "Neutral"

1. Set up initial White Balance condition.
2. Set up COLOR_TEMP=1.
3. Set up TEST_R_LEVEL=204, TEST_G_LEVEL=204 and TEST_B_LEVEL=204 and adjust R_DRIVE and B_DRIVE values to within the spec of the table below.

	X	Y	Spec.
32"	0.2827	0.2920	0.0014
40"	0.2840	0.2826	0.0014
46"	0.2865	0.2845	0.0014

4. Set up TEST_R_LEVEL=51, TEST_G_LEVEL=51 and TEST_B_LEVEL=51 and adjust R_BKG and B_BKG values to within the spec of the table below.

	X	Y	Spec.
32"	0.2827	0.2920	0.0028
40"	0.2840	0.2826	0.0028
46"	0.2865	0.2845	0.0028

5. Continue tracking the values of items 3) and 4) until they are all within spec.
6. Send COLOR_SAVE command.

3-4-4. White Balance of Colour Temperature "Warm 1"

1. Set up initial White Balance condition.
2. Set up COLOR_TEMP=2.
3. Set up TEST_R_LEVEL=204, TEST_G_LEVEL=204 and TEST_B_LEVEL=204 and adjust R_DRIVE and B_DRIVE values to within the spec of the table below.

	X	Y	Spec.
32"	0.2961	0.3096	0.0014
40"	0.2955	0.2999	0.0014
46"	0.2963	0.2972	0.0014

- Set up TEST_R_LEVEL=51, TEST_G_LEVEL=51 and TEST_B_LEVEL=51 and adjust R_BKG and B_BKG values to within the spec of the table below.

	X	Y	Spec.
32"	0.2961	0.3096	0.0028
40"	0.2955	0.2999	0.0028
46"	0.2963	0.2972	0.0028

- Continue tracking the values of items 3) and 4) until they are all within spec.
- Send COLOR_SAVE command.

3-4-5. White Balance of Colour Temperature "Warm 2"

- Set up initial White Balance condition.
- Set up COLOR_TEMP=3.
- Set up TEST_R_LEVEL=204, TEST_G_LEVEL=204 and TEST_B_LEVEL=204 and adjust R_DRIVE and B_DRIVE values to within the spec of the table below.

	X	Y	Spec.
32"	0.3083	0.3244	0.0014
40"	0.3146	0.3190	0.0014
46"	0.3092	0.3127	0.0014

- Set up TEST_R_LEVEL=51, TEST_G_LEVEL=51 and TEST_B_LEVEL=51 and adjust R_BKG and B_BKG values to within the spec of the table below.

	X	Y	Spec.
32"	0.3083	0.3244	0.0028
40"	0.3146	0.3190	0.0028
46"	0.3092	0.3127	0.0028

- Continue tracking the values of items 3) and 4) until they are all within spec.
- Send COLOR_SAVE command.

3-5. Panel Replacement

When replacing the panel please reset the gamma and white balance before performing W/B (See page 26, 3-4) for new panel.

3-6. Board Replacement

3-6-1. AE Board Replacement

When replacing the 'AE' board please readjust the AD (See page 24, 3-2) and readjust the W/B (See page 26, 3-4).

3-6-2. B2H Board Replacement

When replacing the 'B2H' board please readjust the AD (See page 24, 3-2) and readjust the W/B (See page 26, 3-4).

Note :

In the event of a 'B2H' board being re-used in service, please ensure that the Serial number is cleared in the NVM.

4-1. BLOCK DIAGRAMS (2)

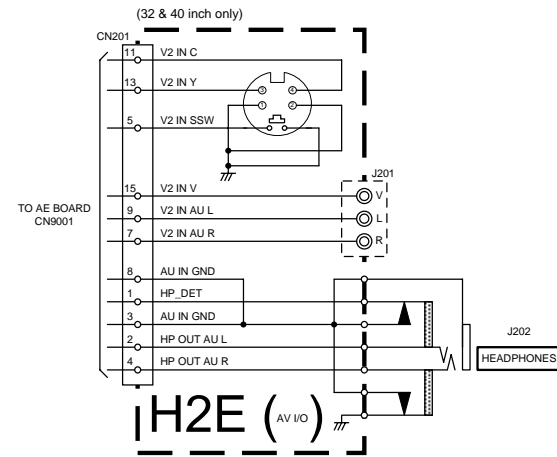
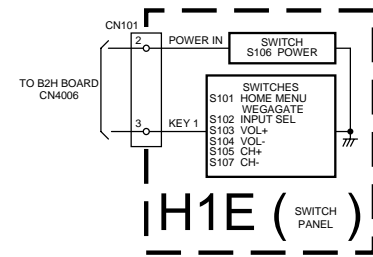
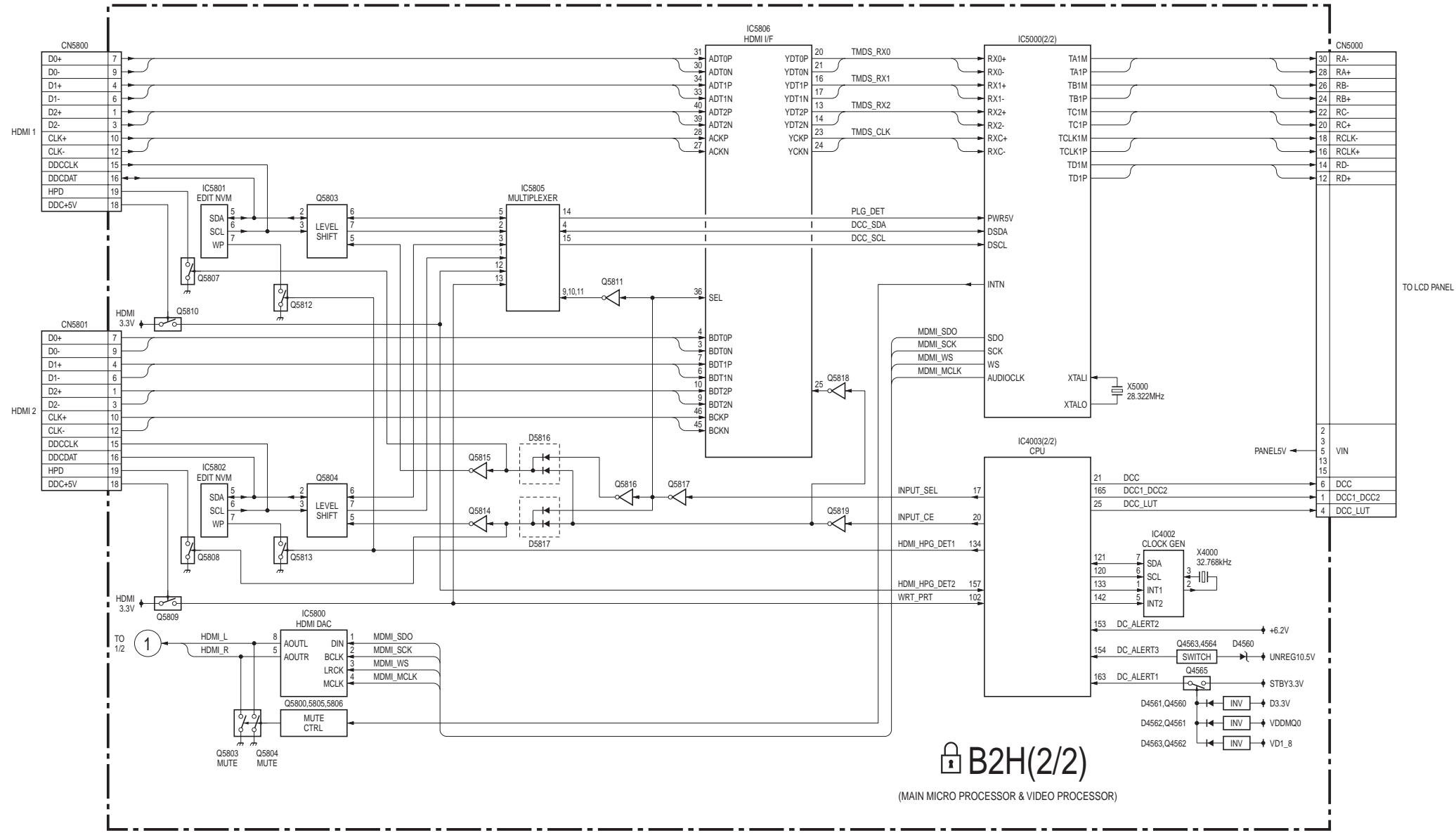

4-1. BLOCK DIAGRAMS (4)

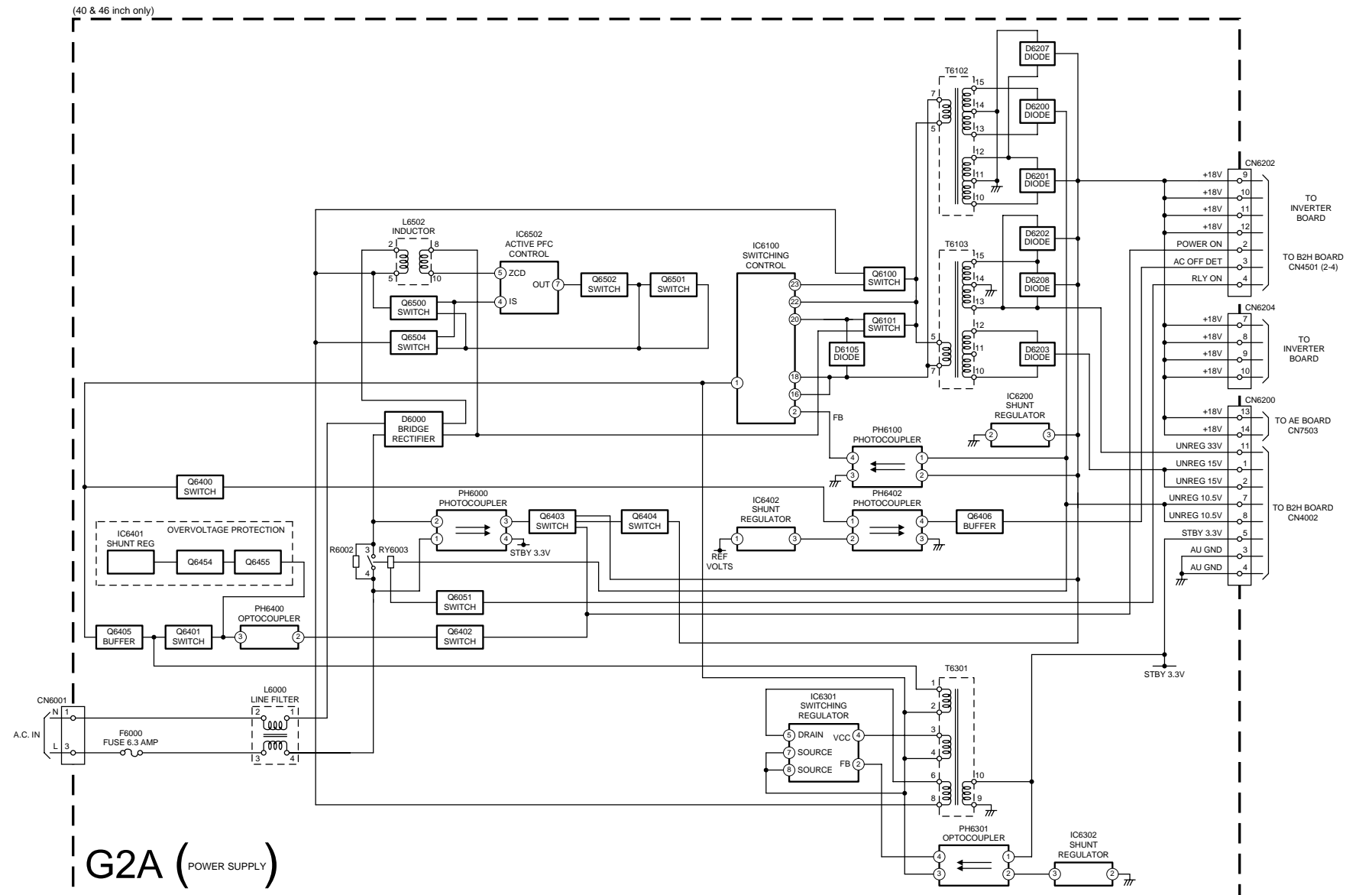
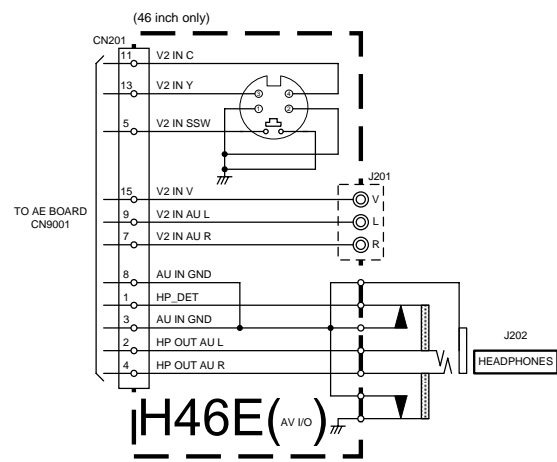
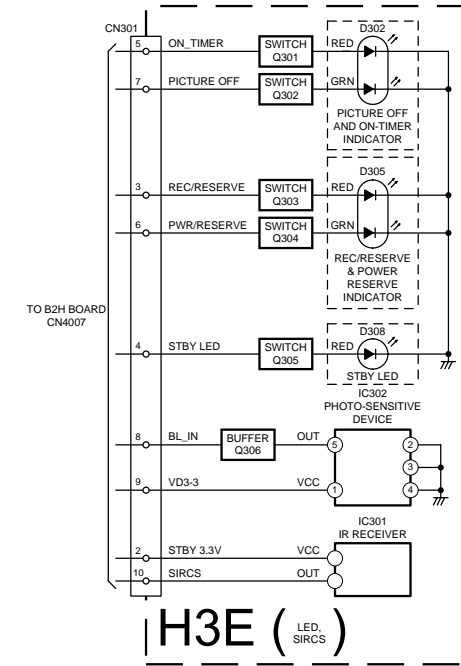
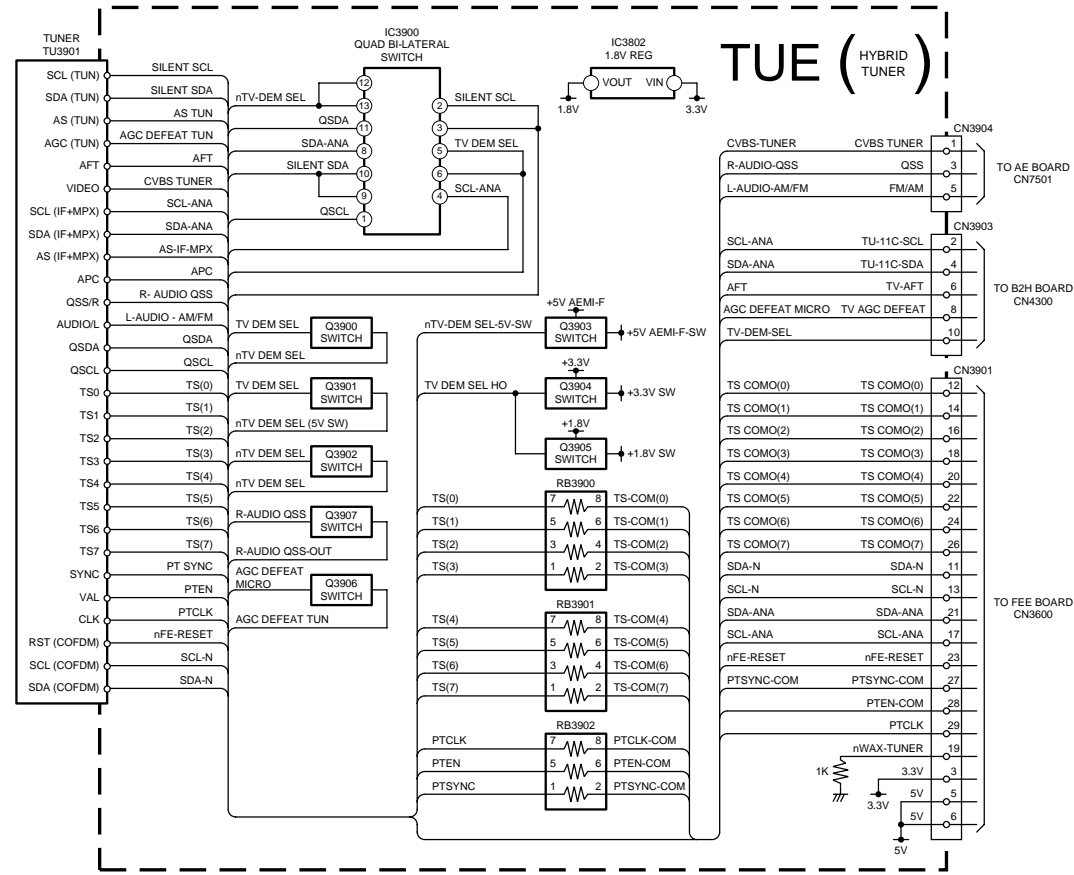

4-1. BLOCK DIAGRAMS (5)

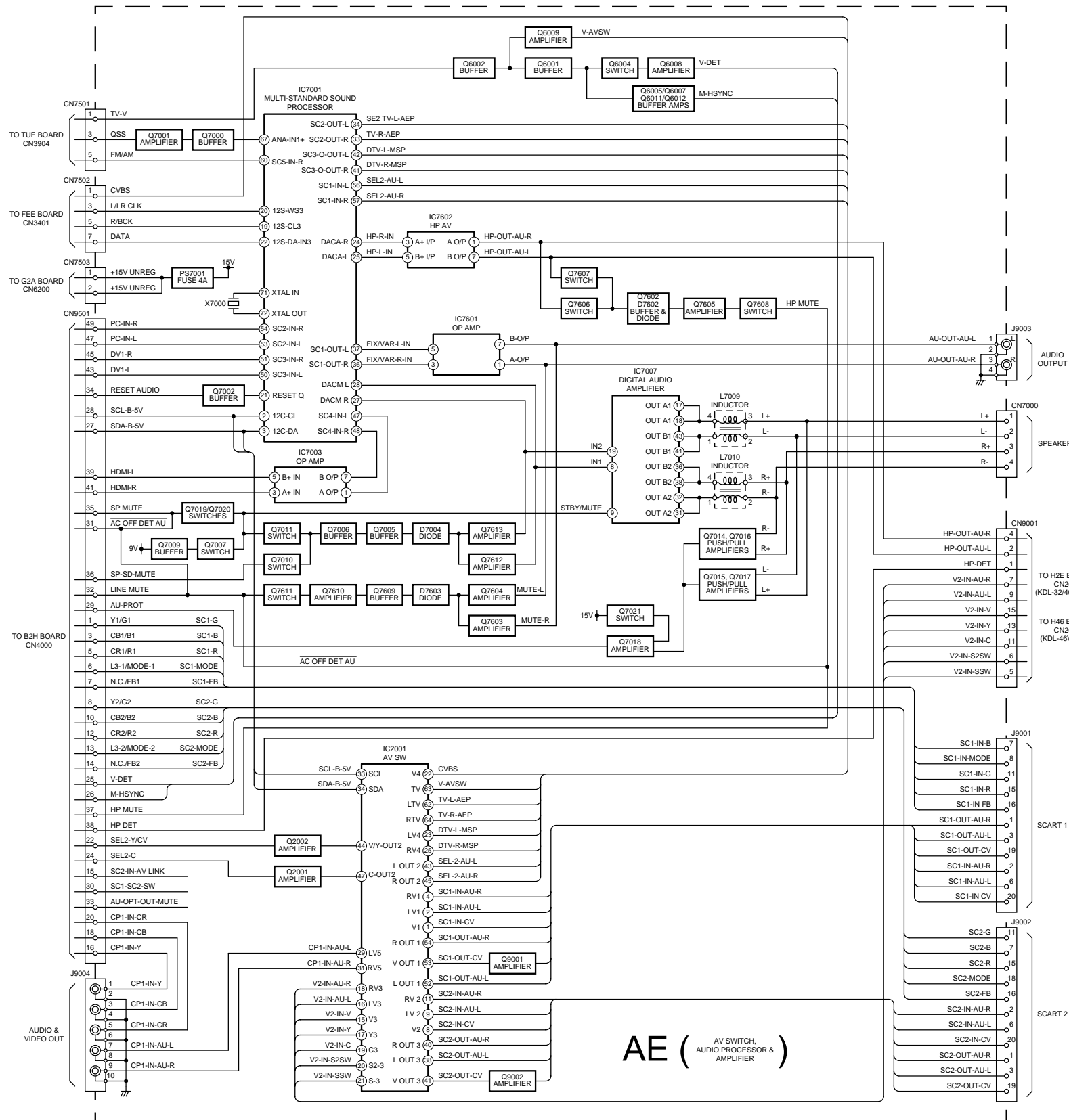

4-2. CIRCUIT BOARD LOCATION

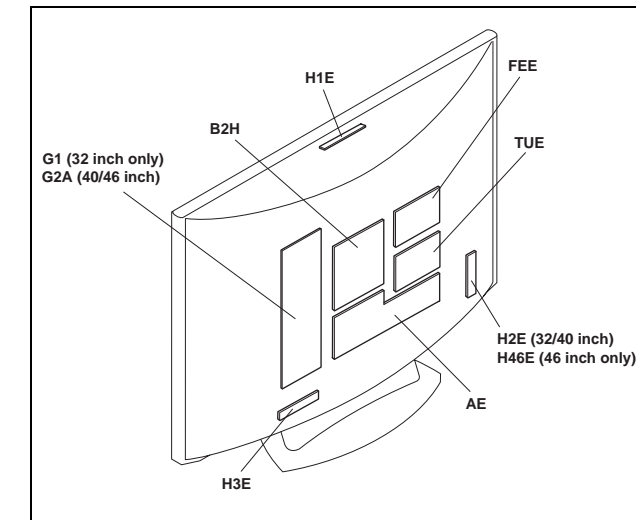

4-3. SCHEMATIC DIAGRAMS AND PRINTED WIRING BOARDS

- Note :**
- All capacitors are in μF unless otherwise noted.
 - pF : μF 50WV or less are not indicated except for electrolytic types.
 - Indication of resistance, which does not have one for rating electrical power, is as follows.

Pitch : 5mm
Electrical power rating : 1/4W

- Chip resistors are 1/10W
- All resistors are in ohms.
k = 1000 ohms, M = 1000,000 ohms
- : nonflammable resistor.
- : fusible resistor.
- : internal component.
- : panel designation or adjustment for repair.
- All variable and adjustable resistors have characteristic curve B, unless otherwise noted.
- All voltages are in Volts.
- Readings are taken with a 10Mohm digital multimeter.
- Readings are taken with a color bar input signal.
- Voltage variations may be noted due to normal production tolerances.
- : B + bus.
- : B - bus.
- : RF signal path.
- : earth - ground.
- : earth - chassis.

Reference Information

RESISTOR	RN	: METAL FILM
	RC	: SOLID
	FPRD	: NON FLAMMABLE CARBON
	FUSE	: NON FLAMMABLE FUSIBLE
	RS	: NON FLAMMABLE METAL OXIDE
	RB	: NON FLAMMABLE CEMENT
	RW	: NON FLAMMABLE WIREWOUND
		: ADJUSTMENT RESISTOR
COIL	LF-8L	: MICRO INDUCTOR
CAPACITOR	TA	: TANTALUM
	PS	: STYROL
	PP	: POLYPROPYLENE
	PT	: MYLAR
	MPS	: METALIZED POLYESTER
	MPP	: METALIZED POLYPROPYLENE
	ALB	: BIPOLAR
	ALT	: HIGH TEMPERATURE
	ALR	: HIGH RIPPLE

Note : The components identified by shading and marked Δ are critical for safety. Replace only with the part numbers specified in the parts list.

Note : Les composants identifiés par une trame et par une marque Δ sont d'une importance critique pour la sécurité. Ne les remplacer que par des pièces de numéro spécifié.

Note : The components identified by mark \square contain confidential information. Strictly follow the instructions whenever the components are repaired and/or replaced.

A B C D E F G H I J K L M N O

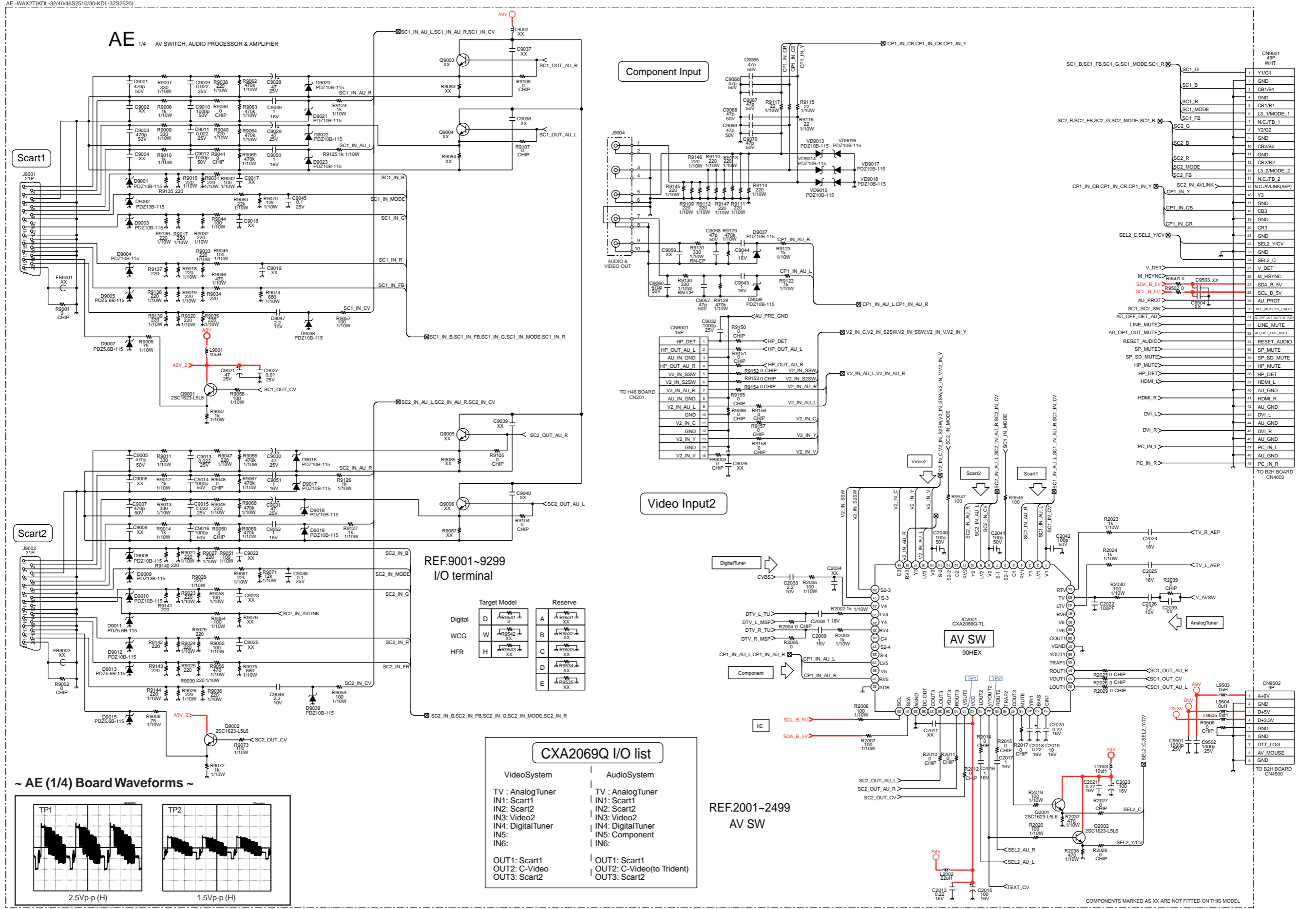

Component Input

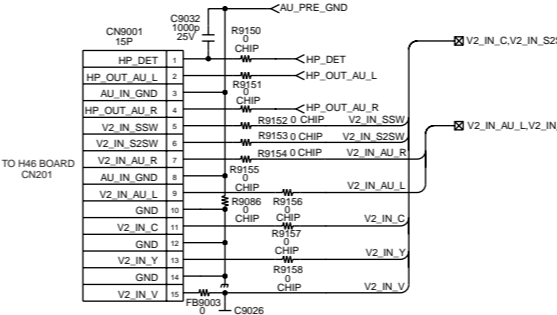
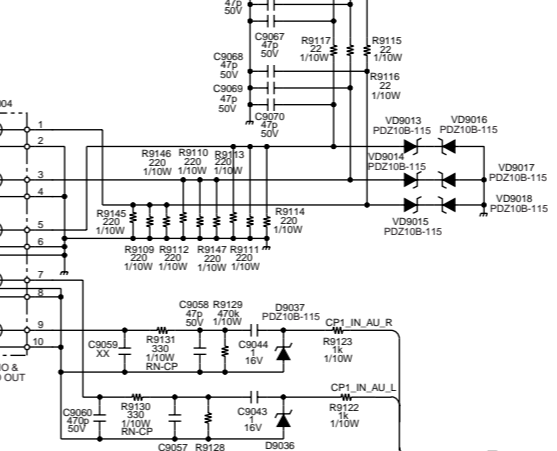

Video Input2

REF.9001-9299 I/O terminal

	Target Model	Reserve
Digital	D R9541	A R9531
WCG	W R9542	B R9532
HFR	H R9543	C R9533
		D R9534
		E R9535

CXA2069Q I/O list

VideoSystem	AudioSystem
TV : AnalogTuner	TV : AnalogTuner
IN1: Scart1	IN1: Scart1
IN2: Scart2	IN2: Scart2
IN3: Video2	IN3: Video2
IN4: DigitalTuner	IN4: DigitalTuner
IN5:	IN5: Component
IN6:	IN6:
OUT1: Scart1	OUT1: Scart1
OUT2: C-Video	OUT2: C-Video(to Trident)
OUT3: Scart2	OUT3: Scart2

REF.2001-2499 AV SW

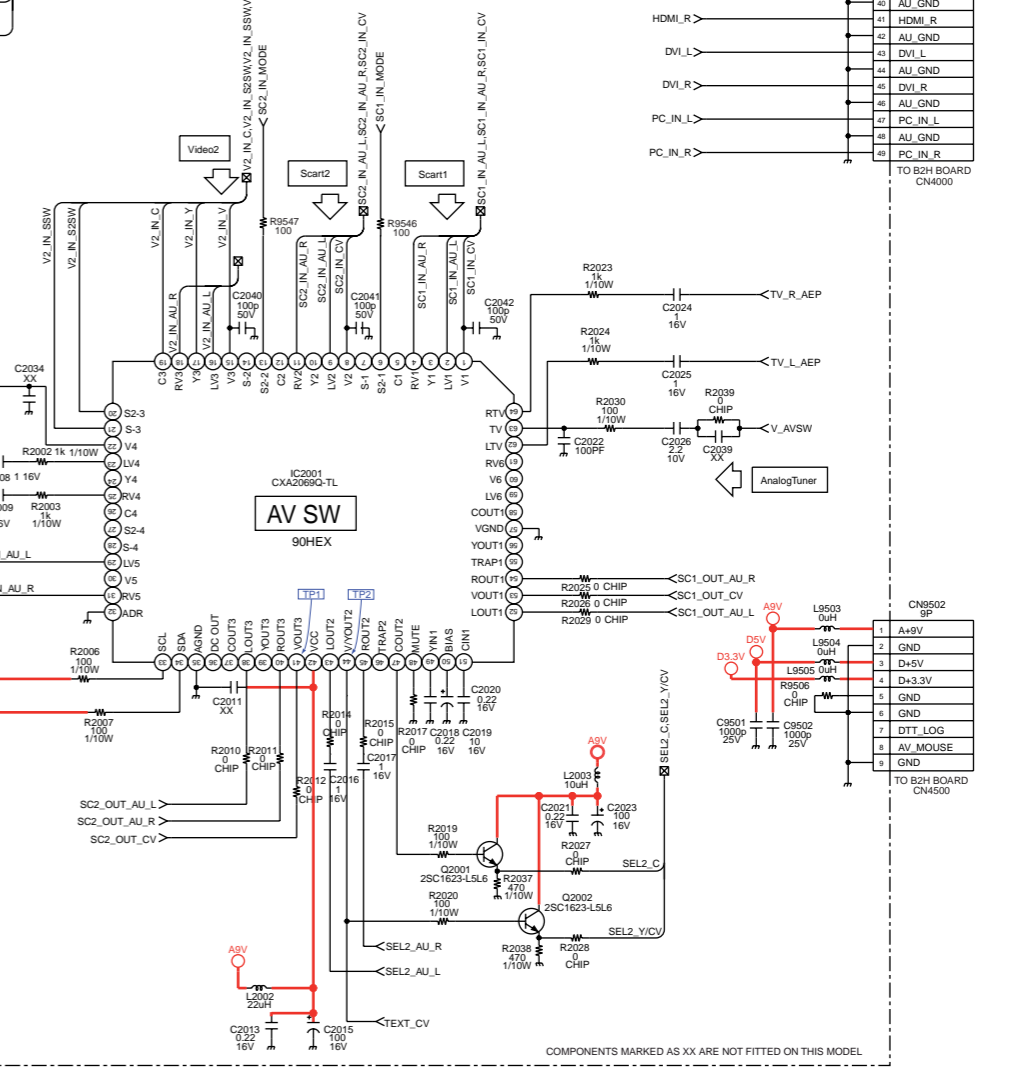

~ AE (1/4) Board Waveforms ~

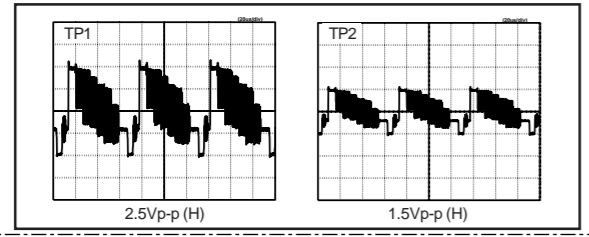

COMPONENTS MARKED AS XX ARE NOT FITTED ON THIS MODEL

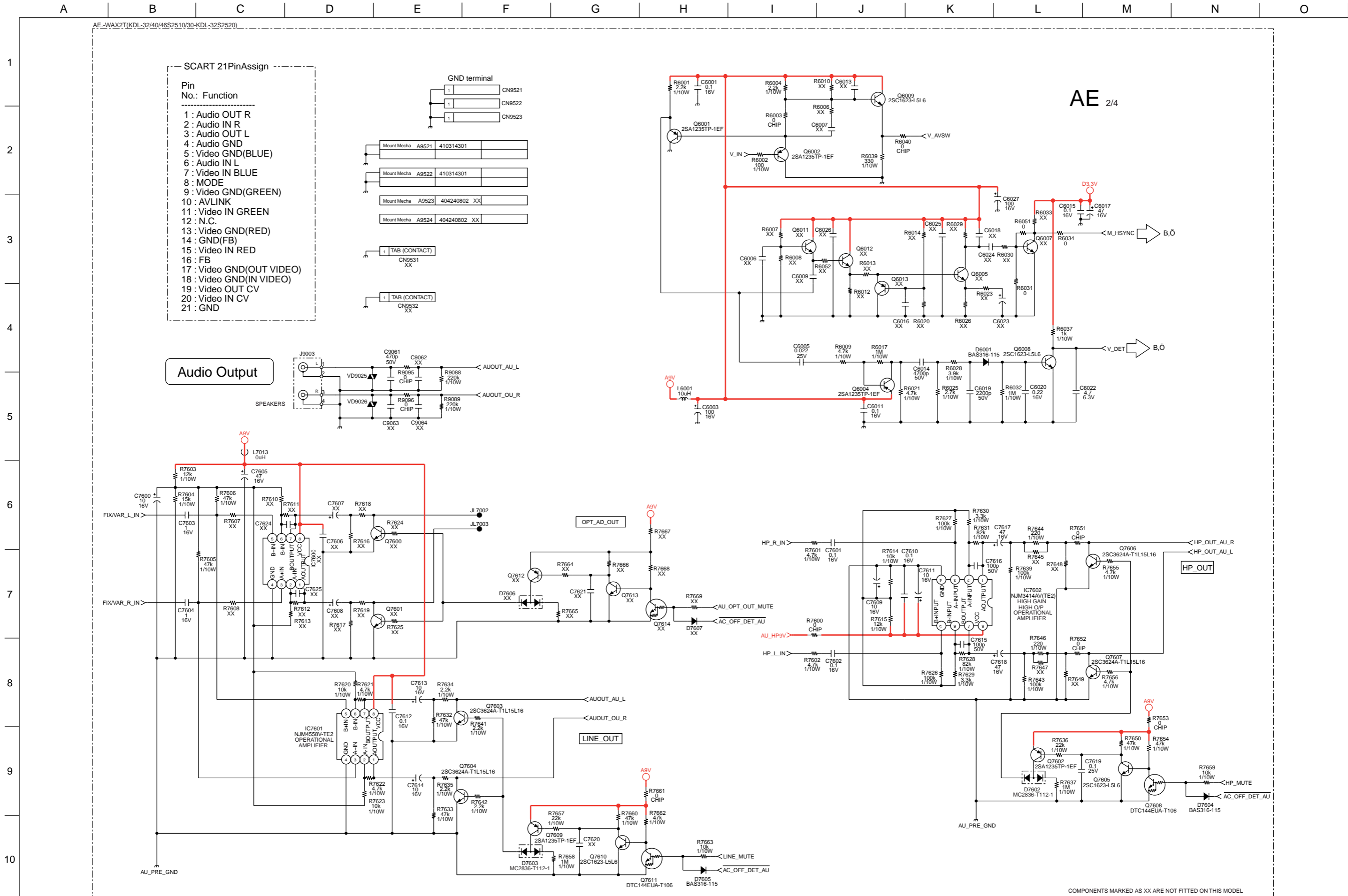

~ AE Board Schematic Diagram [AV Switch, Audio Processor & Amplifier] Page 2/4 ~

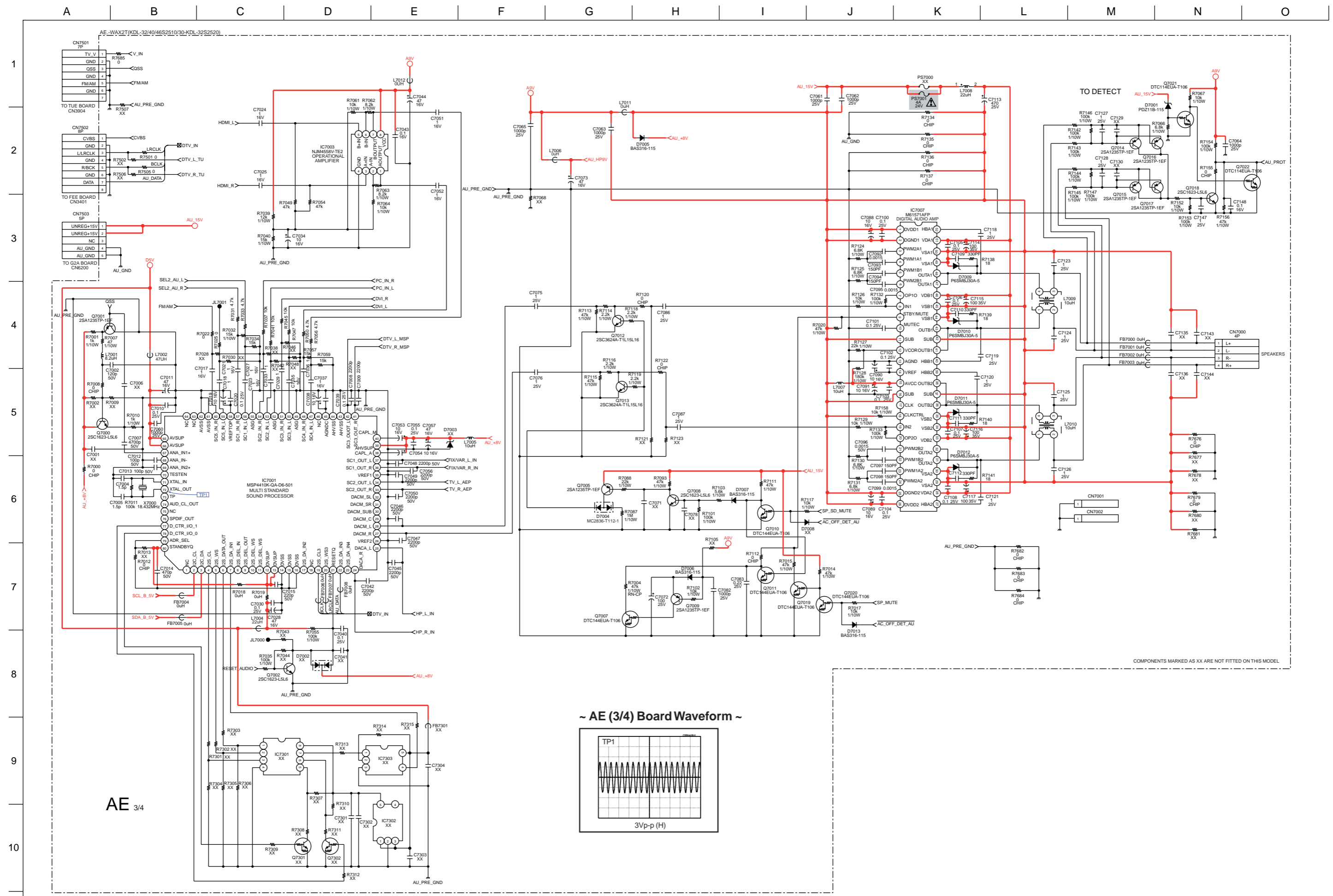

~ AE (3/4) Board Waveform ~

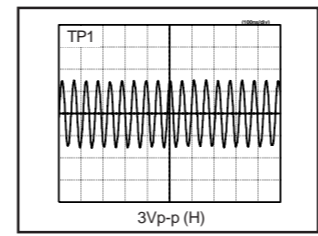

A B C D E F G H I J K L M N O

1
2
3
4
5
6
7
8
9
10
11

~ AE Printed Wiring Board Conductor Side A ~

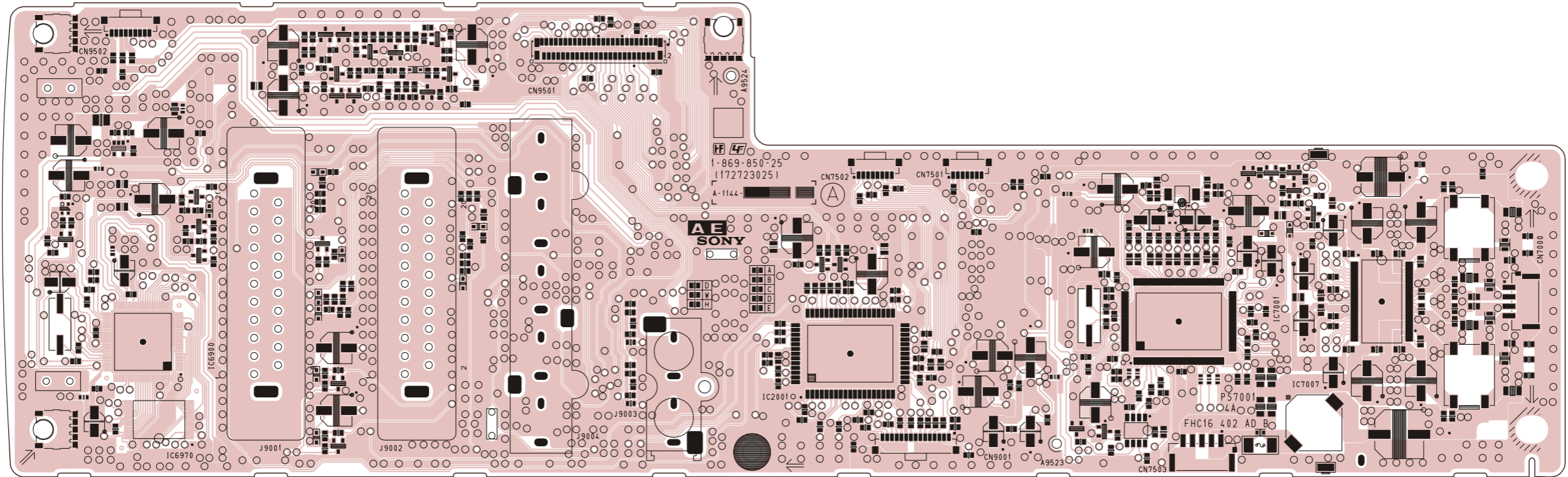

~ AE Board IC Voltage Table Side A ~

Ref No	Pin No	Volts (V)	Ref No	Pin No	Volts (V)	Ref No	Pin No	Volts (V)	Ref No	Pin No	Volts (V)	Ref No	Pin No	Volts (V)	Ref No	Pin No	Volts (V)	Ref No	Pin No	Volts (V)	Ref No	Pin No	Volts (V)						
IC2001	1	3.9	IC2001	11	4.3	IC2001	22	4.2	IC2001	33	4.5	IC2001	44	4.1	IC2001	55	3.6	IC7001	2	4.5	IC7001	23-32	0	IC7001	46	0	IC7001	61-64	0
	2	4.4		12	4.4		23	4.4		34	4.4		45	4.5		56	3.1		3	4.4		33-34	3.8		47-48	3.8		65-66	4.9
	3	3.9		13	0		24	3.9		35-36	0		46	3.6		57	0		4-5	2.5		35	0		49	0		67-68	1.5
	4	4.3		14	4.9		25-26	4.4		37	4.4		47	4.4		58	4.3		6	4.5		36-37	3.8		50-51	3.8		69-70	0
	5	4.4		15	3.9		27	0		38	4.5		48	0		59	4.4		7-11	0		38	7.3		52	0		71	2.4
	6	0		16	4.4		28	4.9		39	3.6		49	3.9		60	3.9		12-13	4.9		39	8.2		53-54	3.8		72	2.3
	7	4.9		17	3.9		29	4.4		40	4.5		50	4.7		61-62	4.4		14-17	0		40	7.3		55	0		73	0
	8	3.9		18-19	4.4		30	3.9		41	4.2		51-52	4.4		63	3.9		18-19	1.7		41-42	3.8		56-57	3.82		74	2.5
	9	4.4		20	0		31	4.4		42	9.0		53	4.2		64	4.4		20-21	4.6		43-44	0		58	2.7		75-79	0
	10	3.9		21	4.9		32	0		43	4.5		54	4.5		IC7001	1		0	22		1.7	45		3.8	59-60		3.8	80

A B C D E F G H I J K L M N O

1
2
3
4
5
6
7
8
9
10
11

~ AE Printed Wiring Board Conductor Side B ~

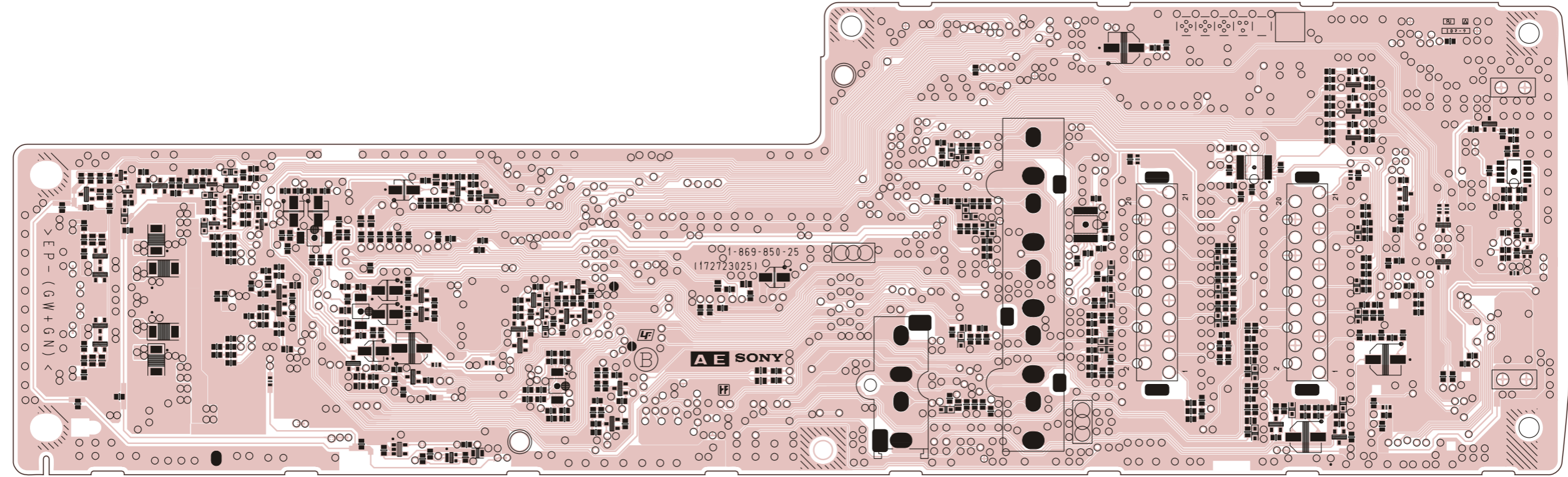

A B C D E F G H I J K L M N O

B2H-WAX2T(KDL-32/40/46S2510/30-KDL-32S2520)

1
2
3
4
5
6
7
8
9
10
11

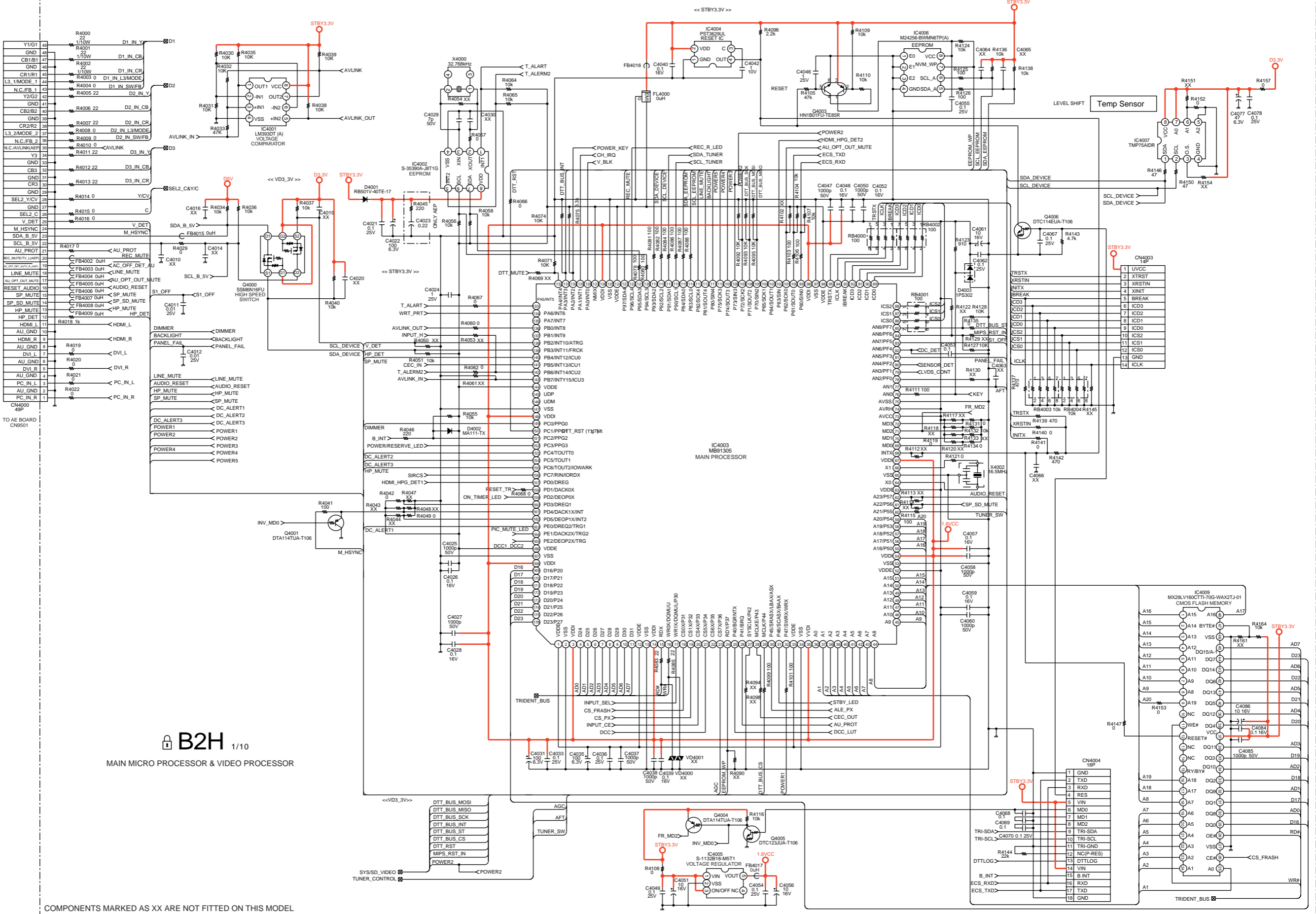

B2H 1/10
MAIN MICRO PROCESSOR & VIDEO PROCESSOR

COMPONENTS MARKED AS XX ARE NOT FITTED ON THIS MODEL

A B C D E F G H I J K L M N O

1
2
3
4
5
6
7
8
9
10
11

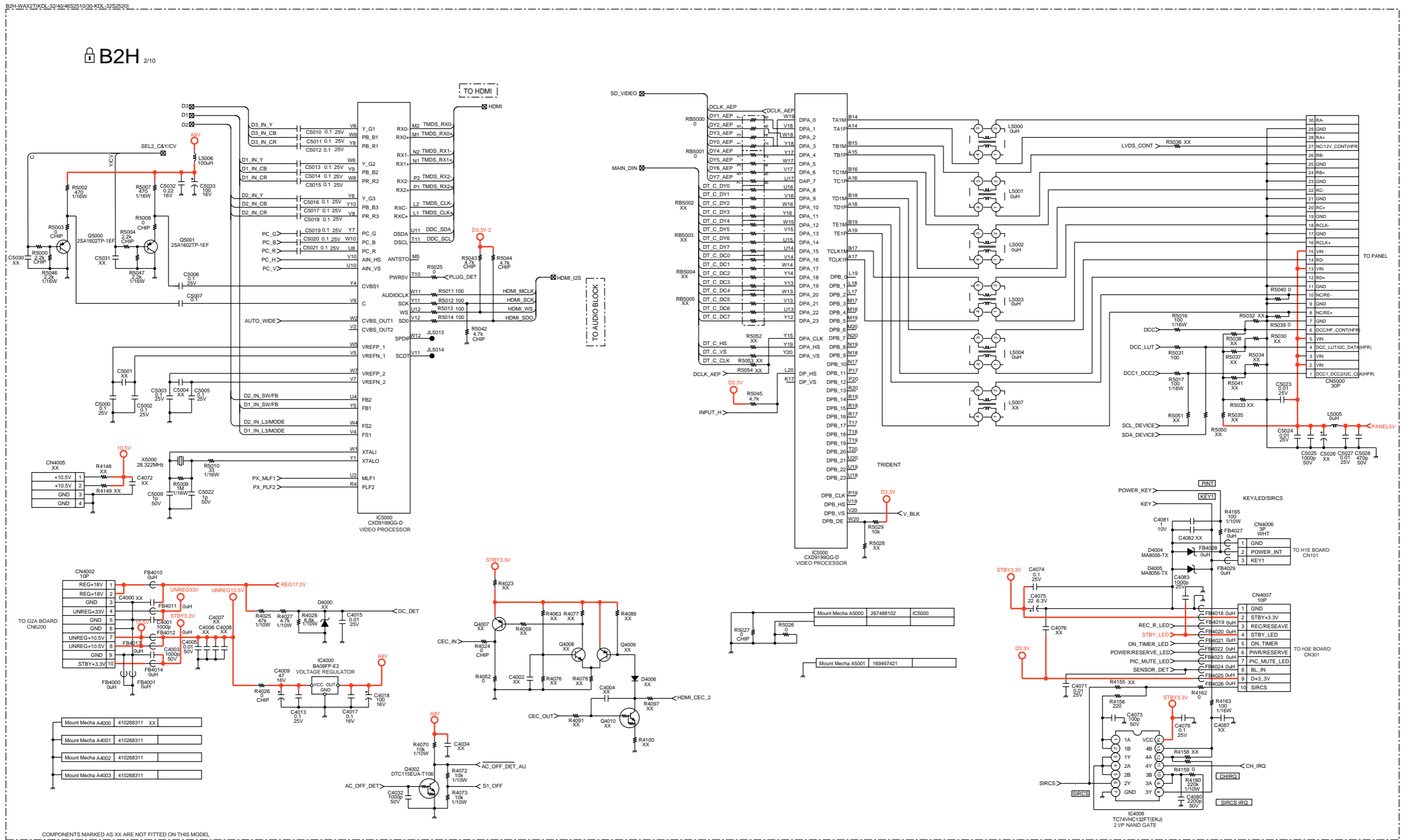

~ B2H Board Schematic Diagram [Main Micro Processor & Video Processor] Page 2/10 ~

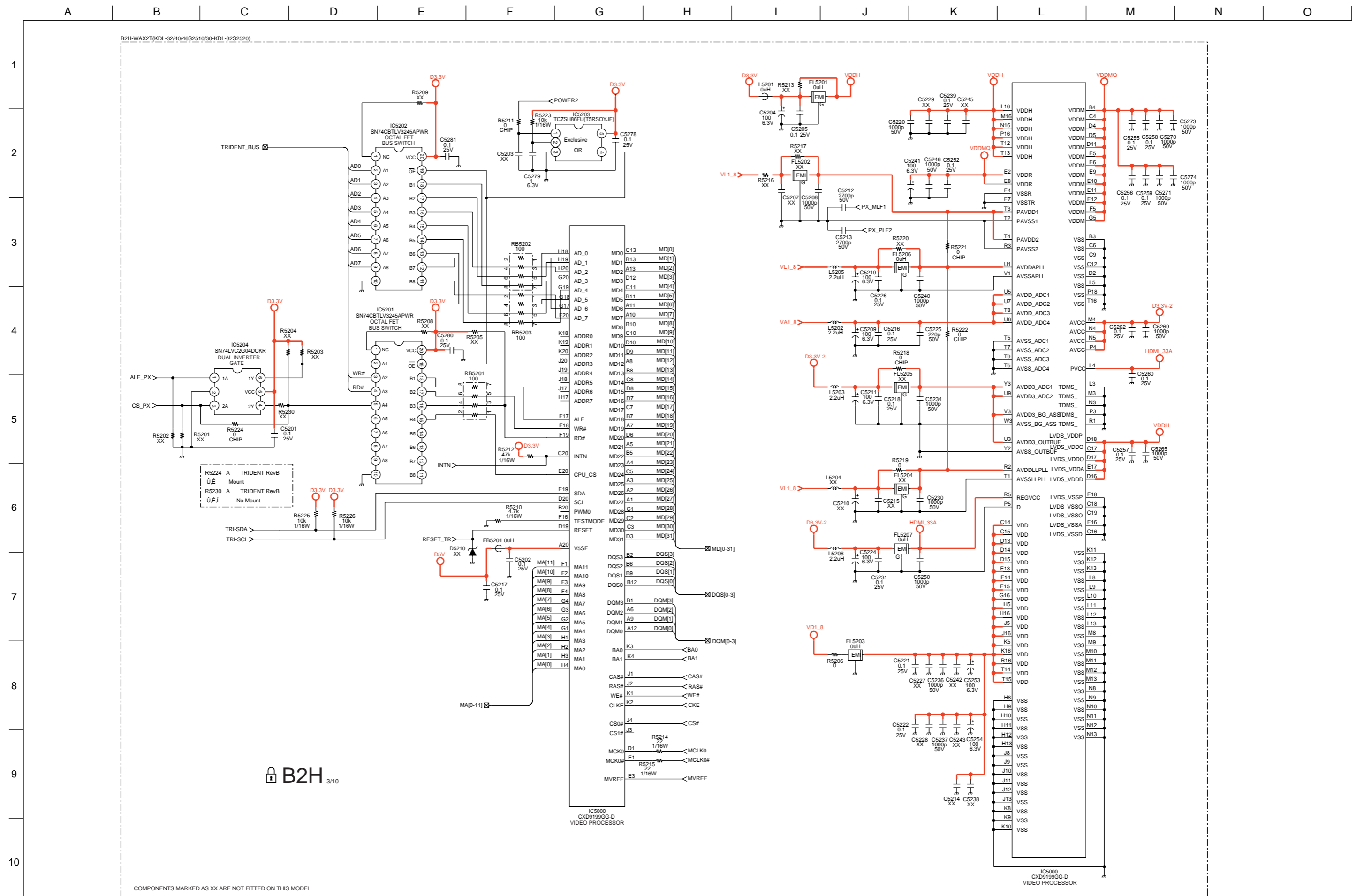

B2H 3/10

A B C D E F G H I J K L M N O

1
2
3
4
5
6
7
8
9
10
11

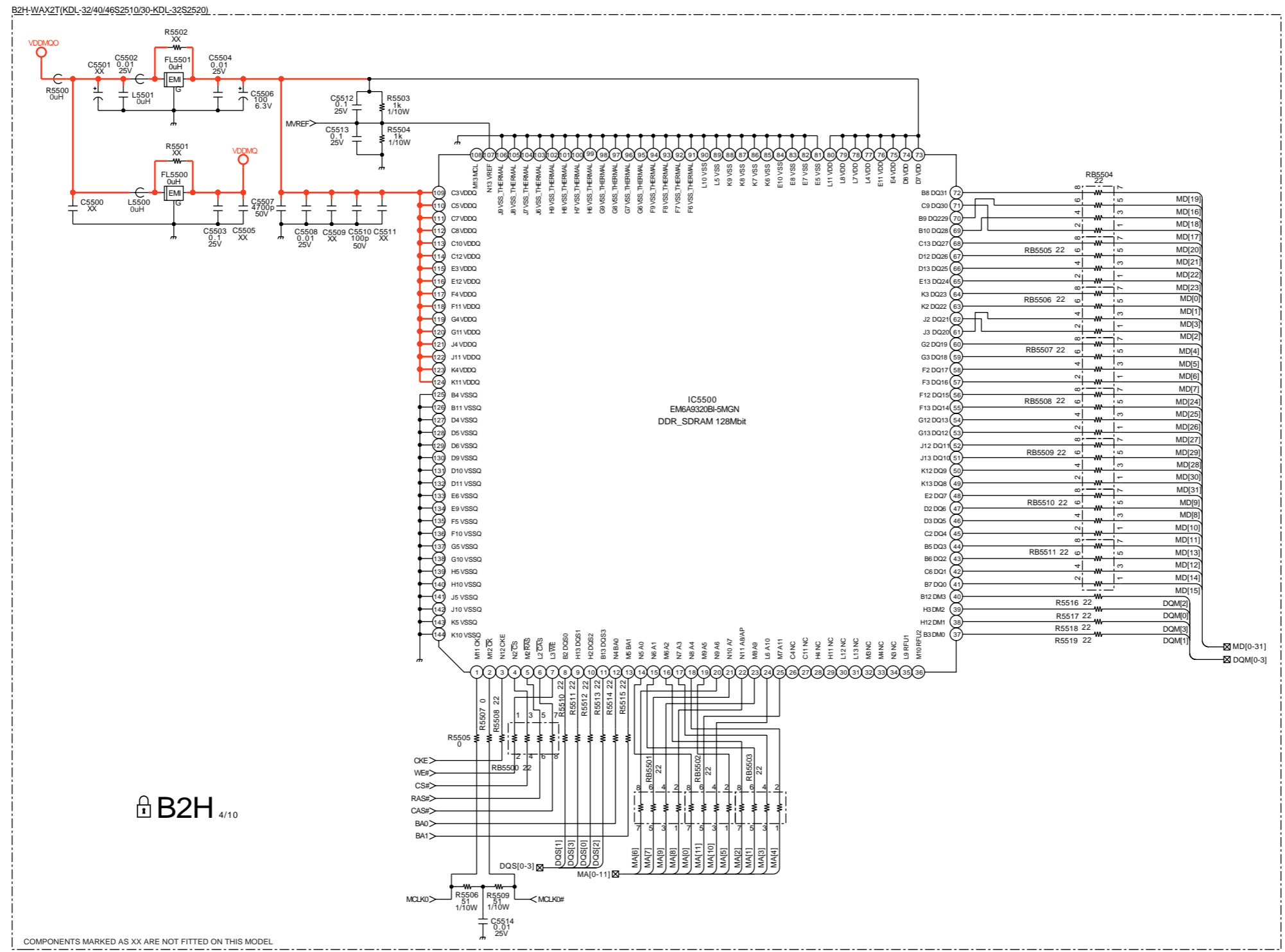

A B C D E F G H I J K L M N O

1
2
3
4
5
6
7
8
9
10
11

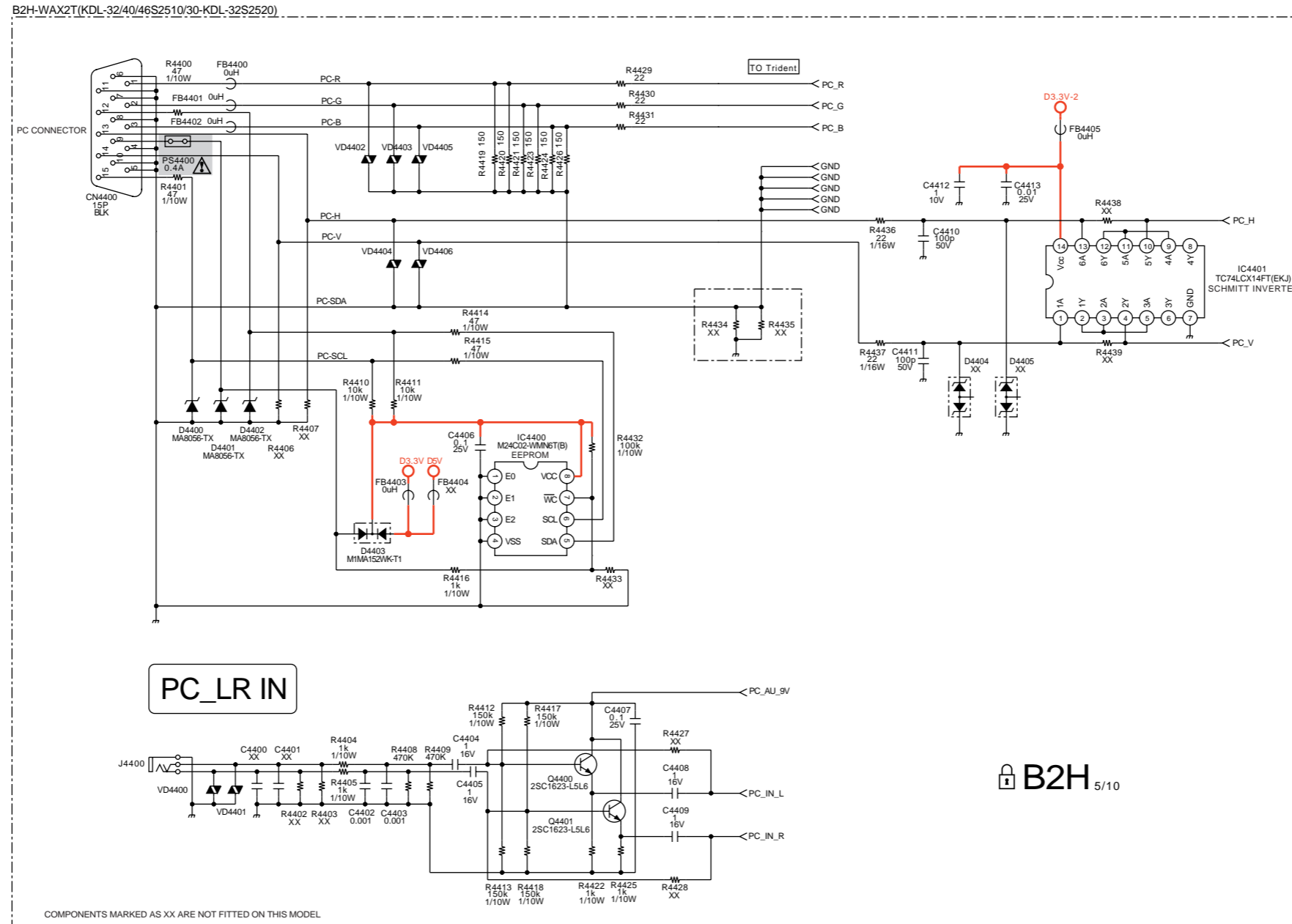

A B C D E F G H I J K L M N O

B2H-WAX2T(KDL-32/40/46S2510/30-KDL-32S2520)

AUDIO IN

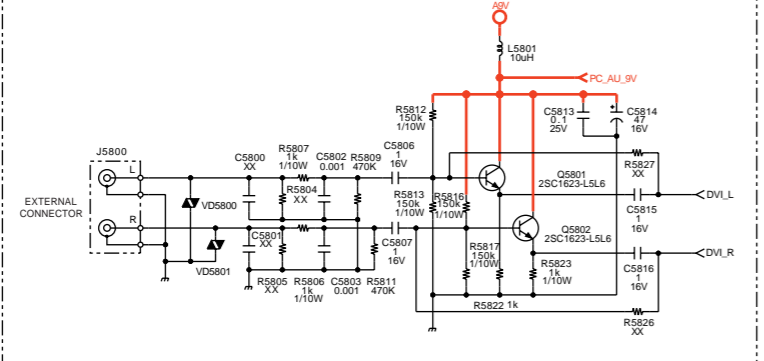

HDMI_D/A

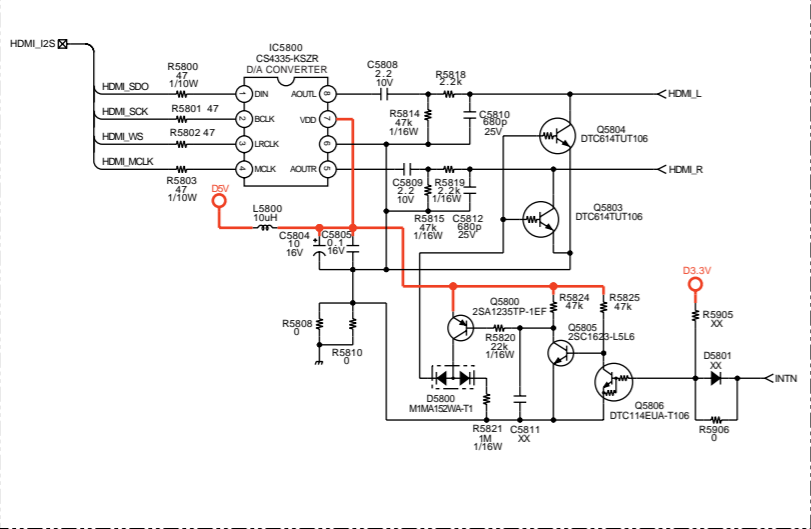

B2H 6/10

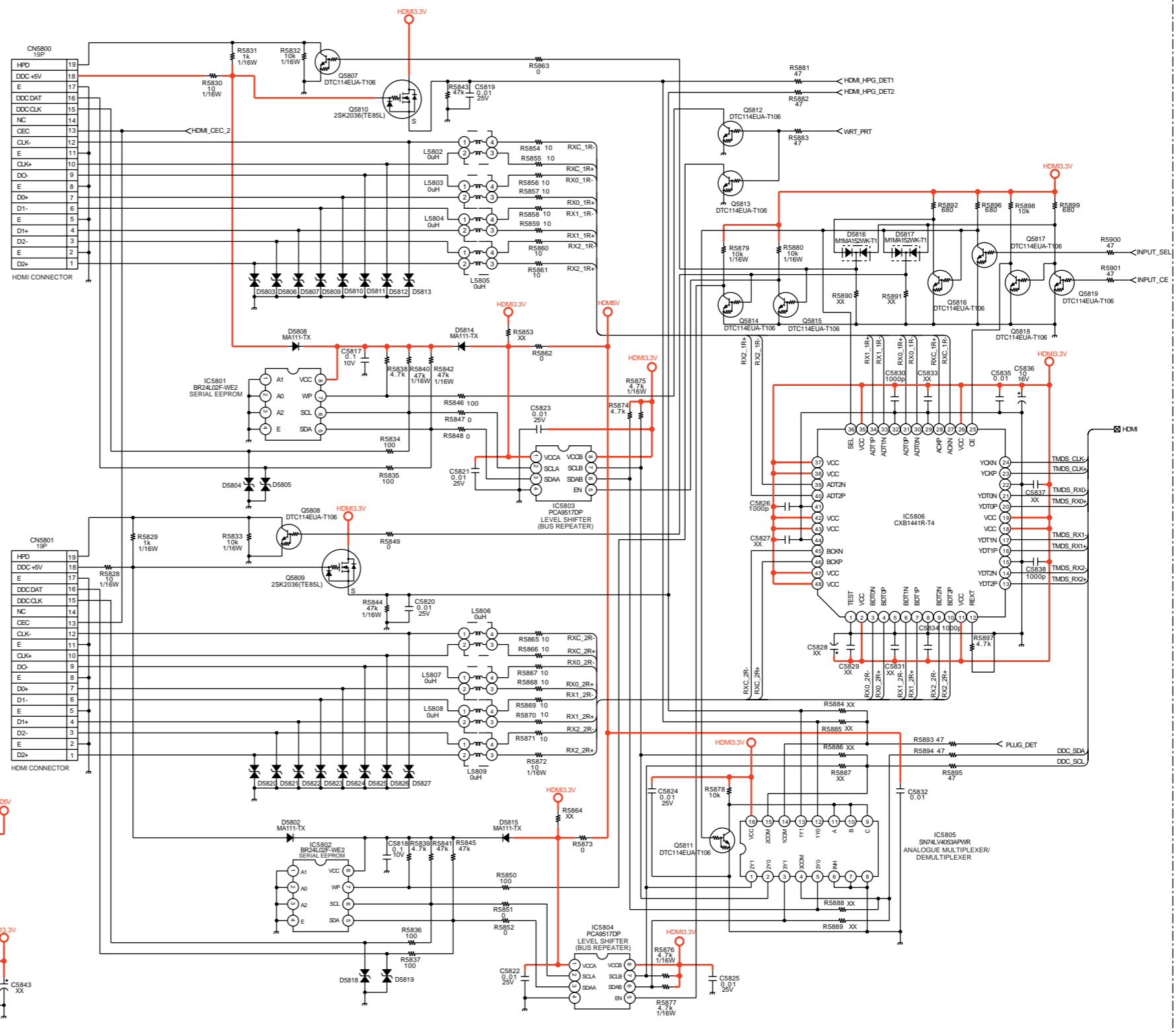
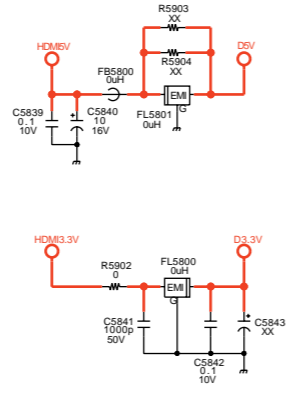

COMPONENTS MARKED AS XX ARE NOT FITTED ON THIS MODEL

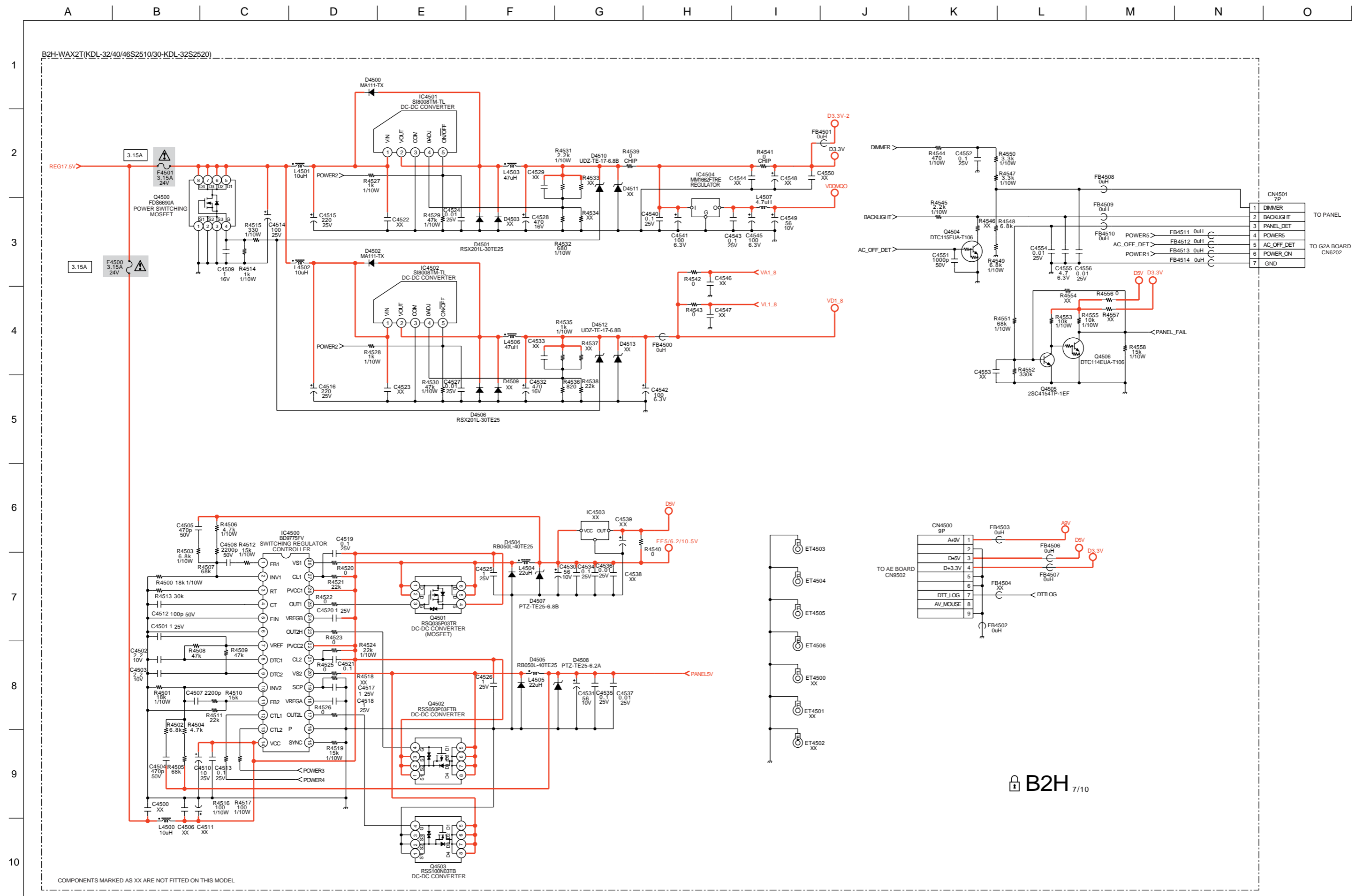

B2H 7/10

A B C D E F G H I J K L M N O

1
2
3
4
5
6
7
8
9
10
11

B2H-WAX2T(KDL-32/40/46S2510/30-KDL-32S2520)

J	AEP	U/C
C4574 XX	C4570 0.001 50V	C4560 XX
1	2	
C4561 XX	C4562 XX	C4563 XX

B2H 8/10

COMPONENTS MARKED AS XX ARE NOT FITTED ON THIS MODEL

DC_ALERT

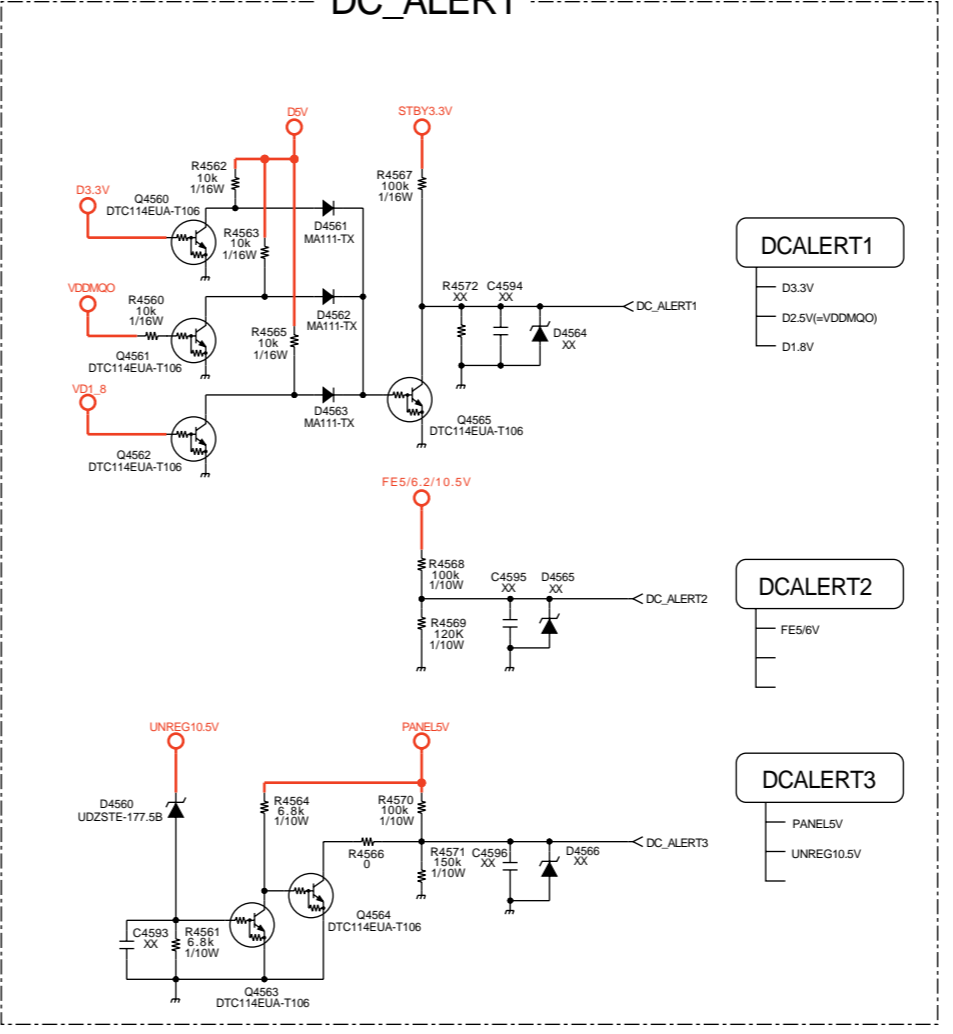

DC_ALERT1

DC_ALERT2

DC_ALERT3

A B C D E F G H I J K L M N O

1
2
3
4
5
6
7
8
9
10
11

B2H-WAX2T(KDL-32/40/46S2510/30-KDL-32S2520)

SYSTEM(J)/SD_VIDEO(UK)

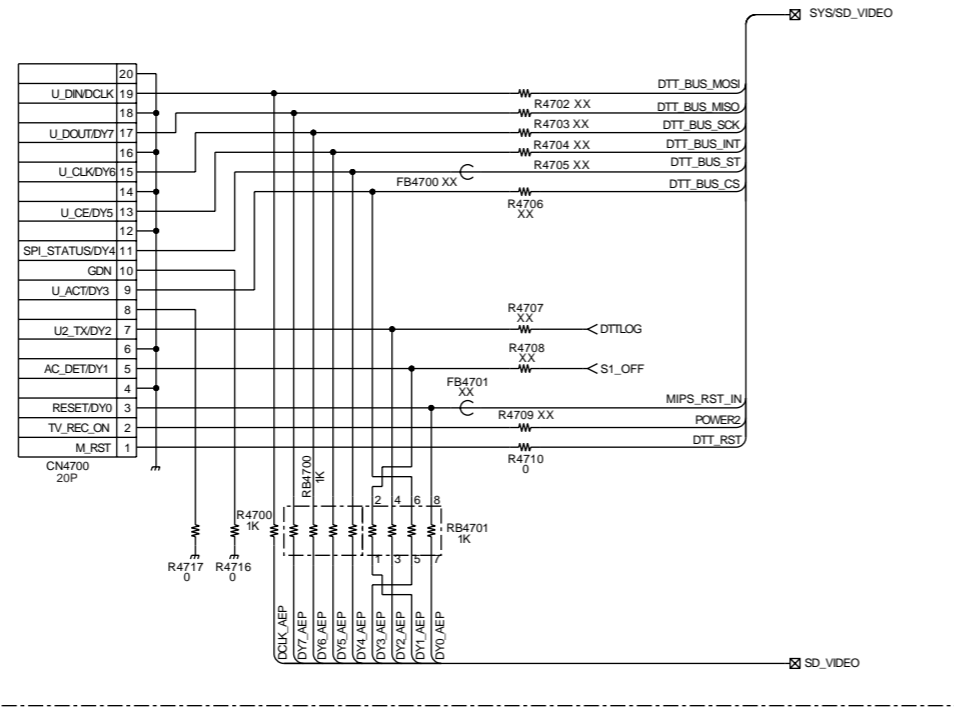

FROM F/E HD VIDEO(DIGITAL)

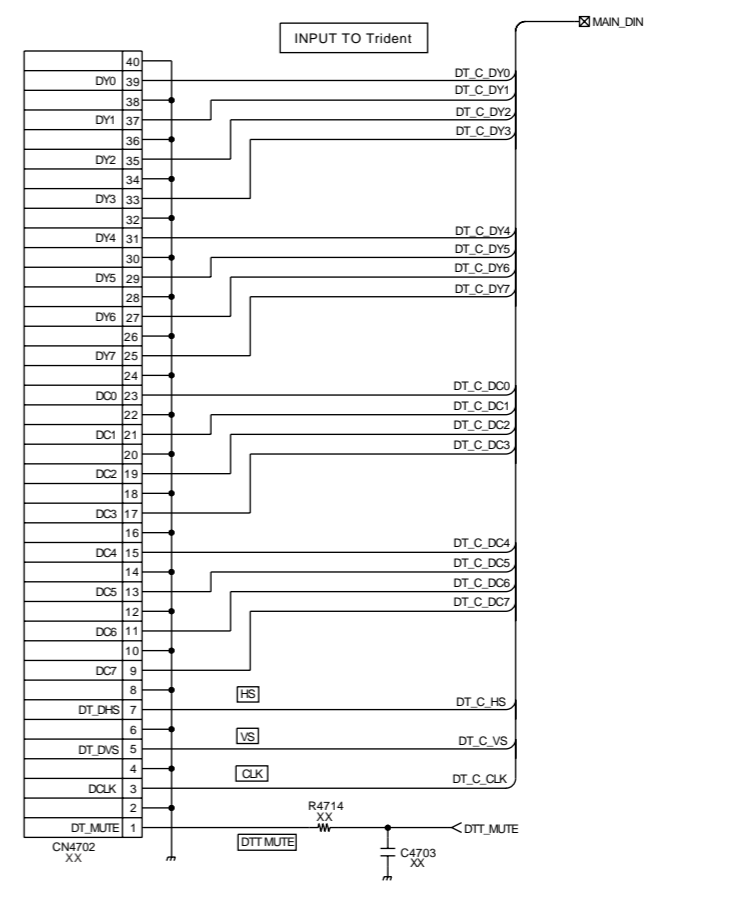

TO F/E POWER(J&U/C)

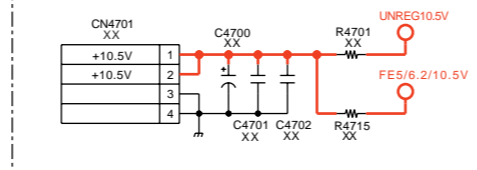

B2H 9/10

COMPONENTS MARKED AS XX ARE NOT FITTED ON THIS MODEL

A B C D E F G H I J K L M N O

1
2
3
4
5
6
7
8
9
10
11

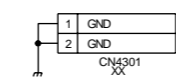
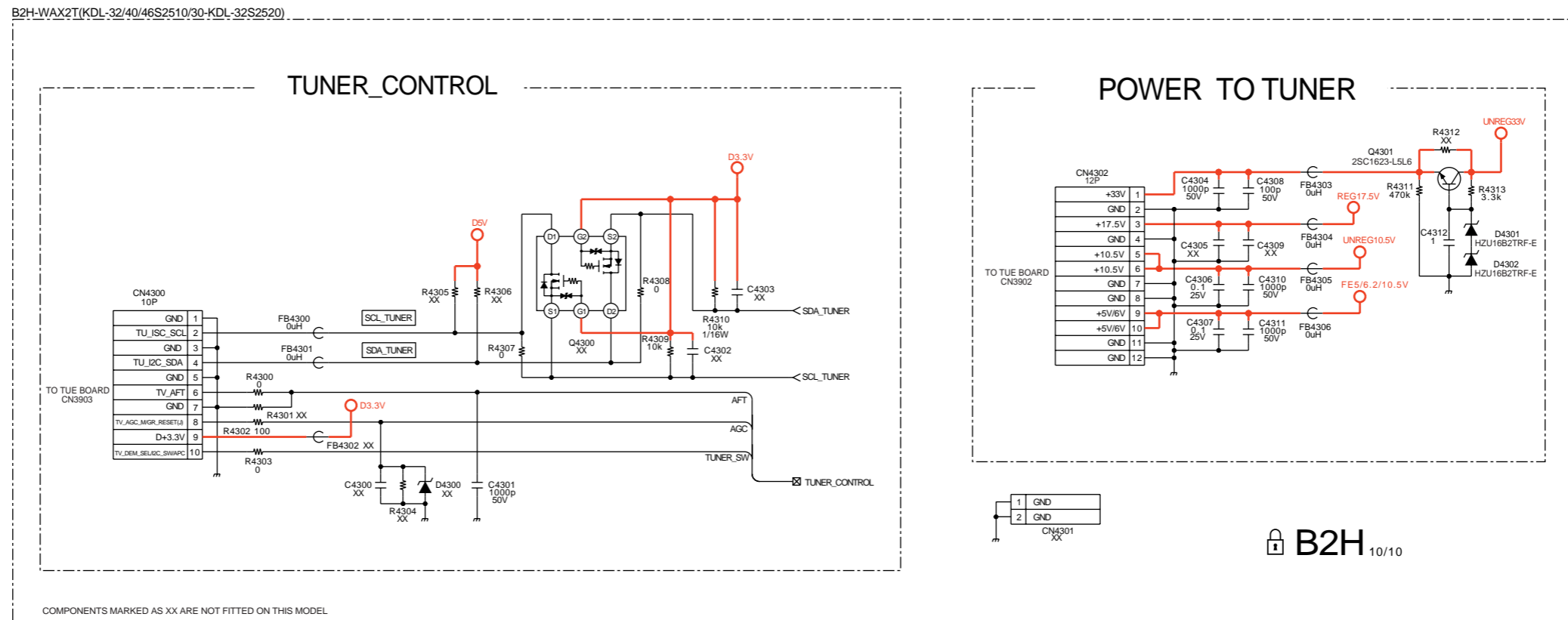

B2H 10/10

A B C D E F G H I J K L M N O

1
2
3
4
5
6
7
8
9
10
11

~ B2H Printed Wiring Board Conductor Side A ~

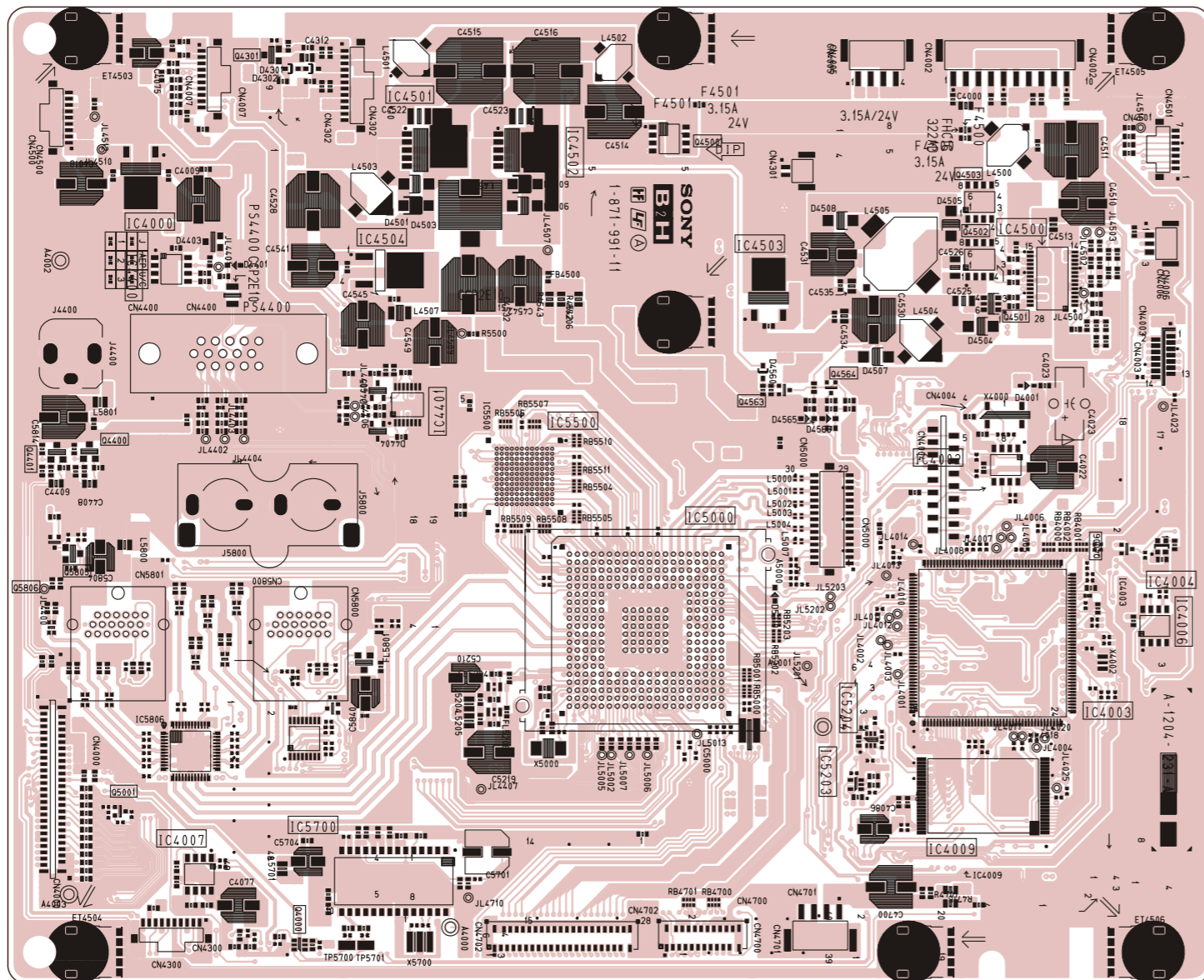

~ B2H Board Semiconductor Location Table Side A ~

DIODE		D4508	G - 4	IC4009	H - 8	IC5204	G - 7	Q4500	F - 3
D4001	H - 5	D4560	F - 5	IC4400	B - 4	IC5500	E - 5	Q4501	H - 5
D4301	C - 3	IC		IC4401	D - 5	IC5806	B - 7	Q4502	H - 4
D4302	C - 3	IC4000	B - 4	IC4500	H - 4	TRANSISTOR		Q4503	H - 4
D4401	C - 4	IC4002	G - 5	IC4501	D - 3	Q4000	C - 9	Q4563	F - 5
D4403	C - 4	IC4003	H - 7	IC4502	E - 4	Q4006	H - 6	Q4564	G - 5
D4501	D - 4	IC4004	I - 6	IC4504	D - 4	Q4301	C - 3	Q5001	B - 8
D4505	H - 4	IC4006	I - 7	IC5000	E - 5	Q4400	B - 5	Q5805	B - 6
D4507	G - 5	IC4007	C - 8	IC5203	G - 8	Q4401	B - 5	Q5806	B - 6

A B C D E F G H I J K L M N O

1
2
3
4
5
6
7
8
9
10
11

~ B2H Printed Wiring Board Conductor Side B ~

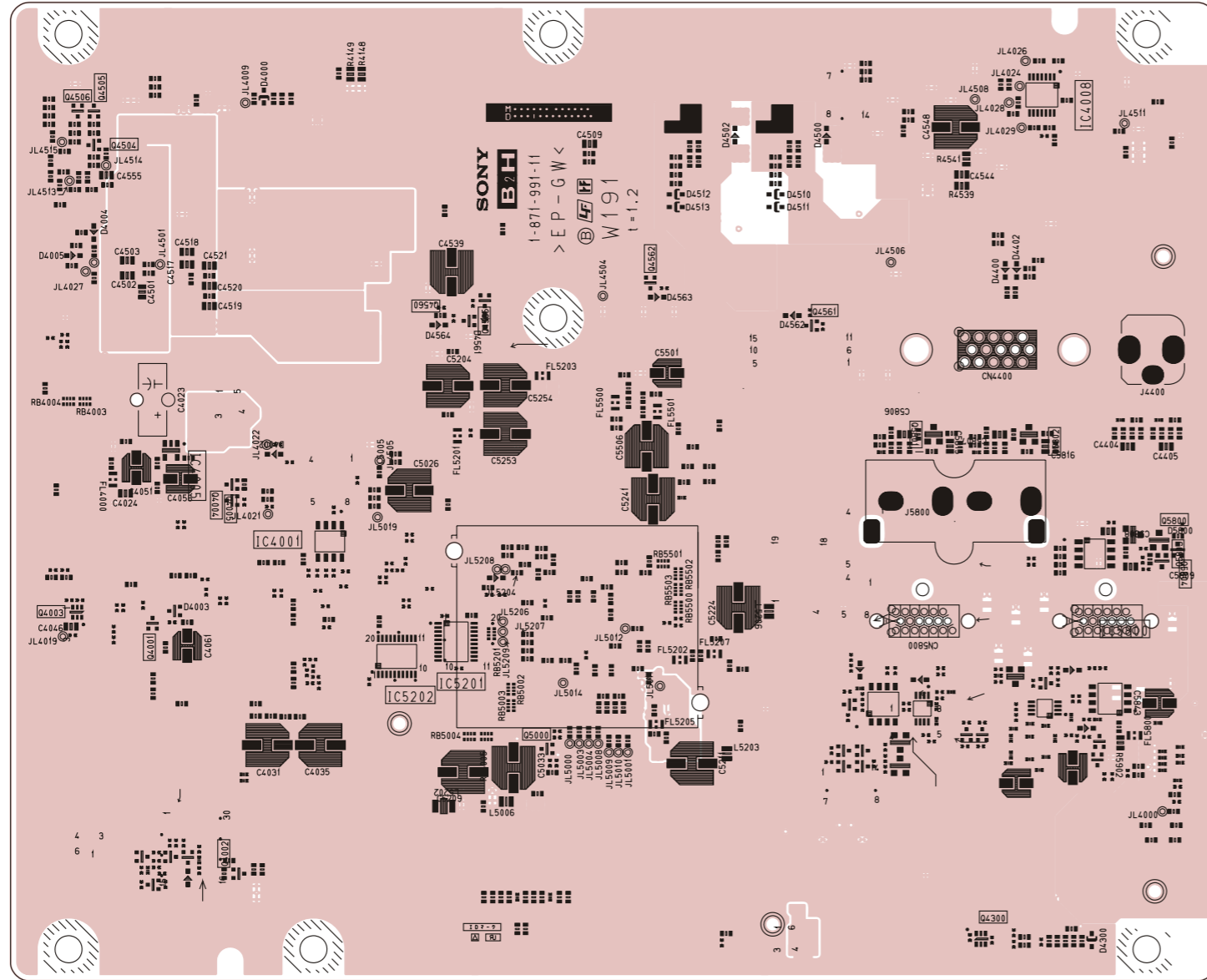

~ B2H Board Semiconductor Location Table Side B ~

DIODE		D4512	F - 4	IC5202	D - 7	Q4560	D - 5
D4002	C - 6	D4561	D - 5	TRANSISTOR		Q4561	G - 5
D4003	C - 7	D4562	F - 5	Q4001	B - 7	Q4562	F - 4
D4004	B - 4	D4563	F - 5	Q4002	C - 8	Q4565	D - 5
D4005	B - 4	D5800	I - 6	Q4003	B - 7	Q5000	E - 7
D4400	H - 4	IC		Q4004	C - 6	Q5800	I - 6
D4500	G - 4	IC4001	C - 6	Q4005	C - 6	Q5801	G - 5
D4502	F - 4	IC4005	C - 6	Q4504	B - 4	Q5802	H - 5
D4510	F - 4	IC4008	H - 3	Q4505	B - 3	Q5803	I - 6
		IC5201	D - 7	Q4506	B - 3	Q5804	I - 6

A B C D E F G H I J K L M N O

1
2
3
4
5
6
7
8
9
10
11

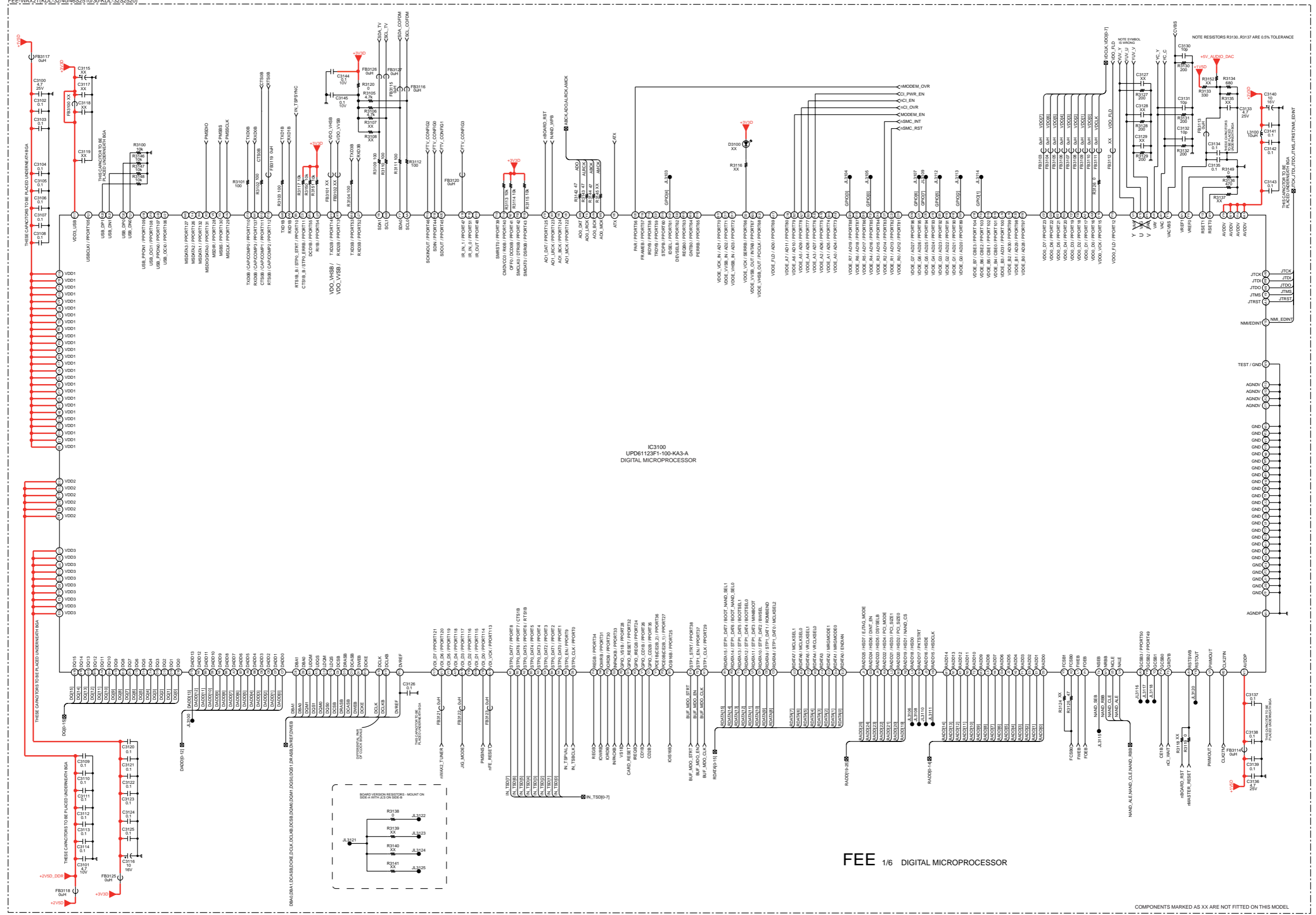

FEE 1/6 DIGITAL MICROPROCESSOR

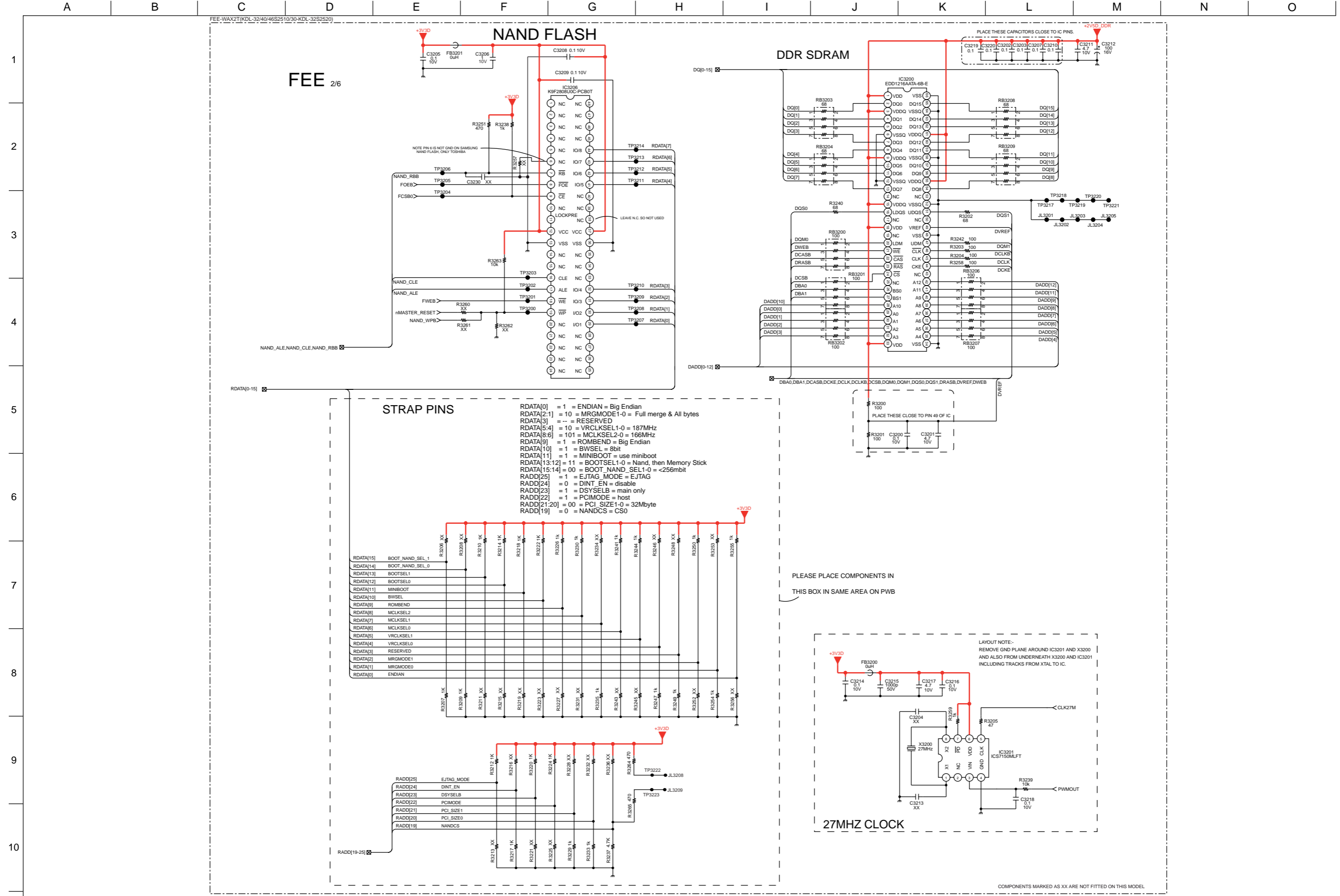

A B C D E F G H I J K L M N O

FEE-WAX2T(KDL-3240/46S2510/30-KDL-32S2520)

FEE 4/6

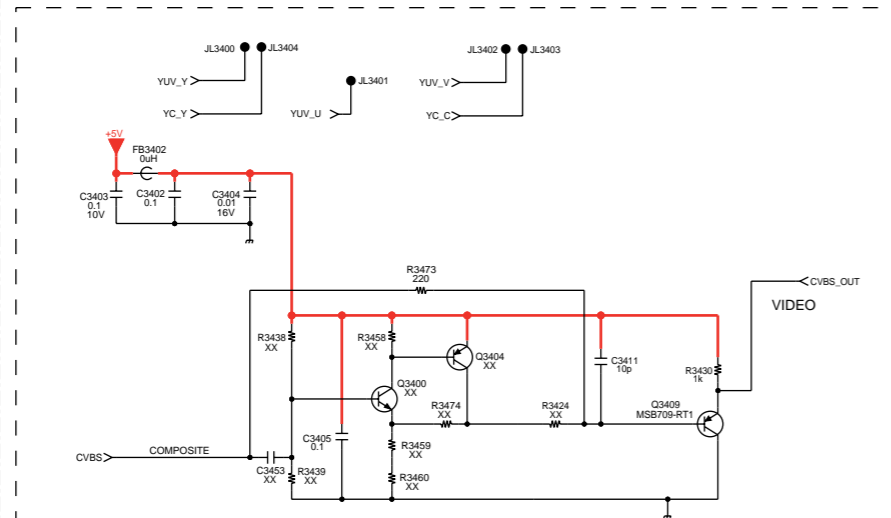

VIDEO AMPS/BUFFERS

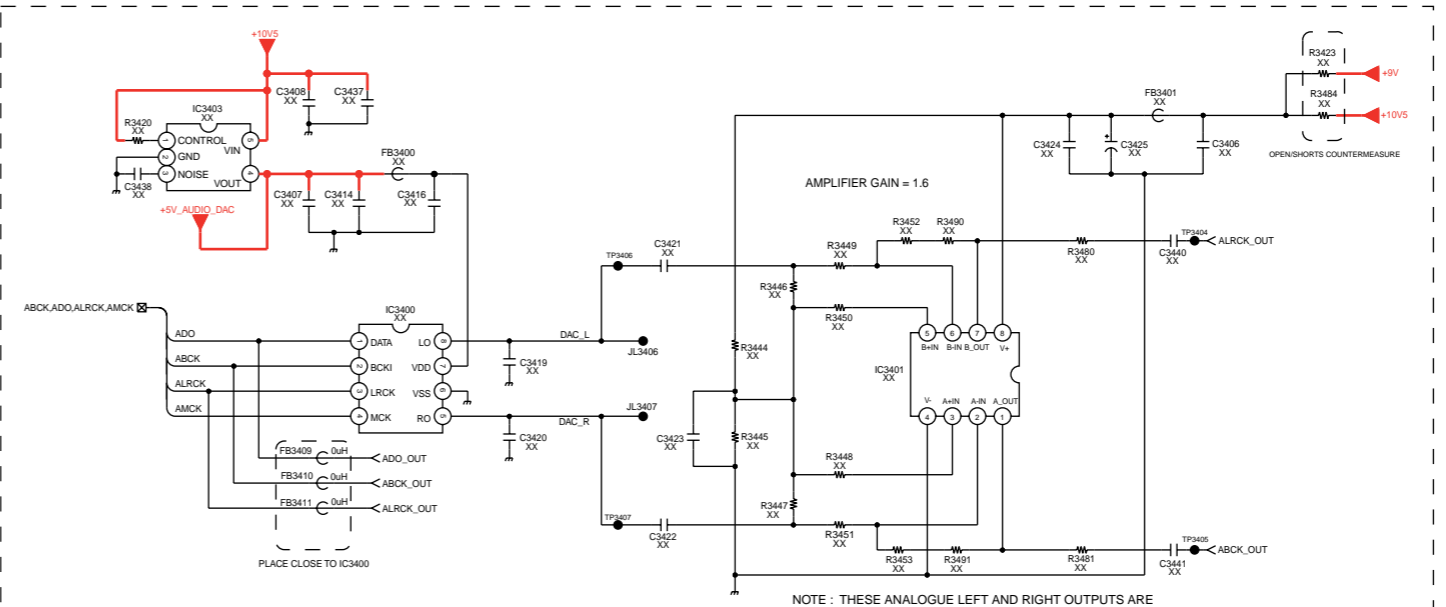

AUDIO DAC & AMP

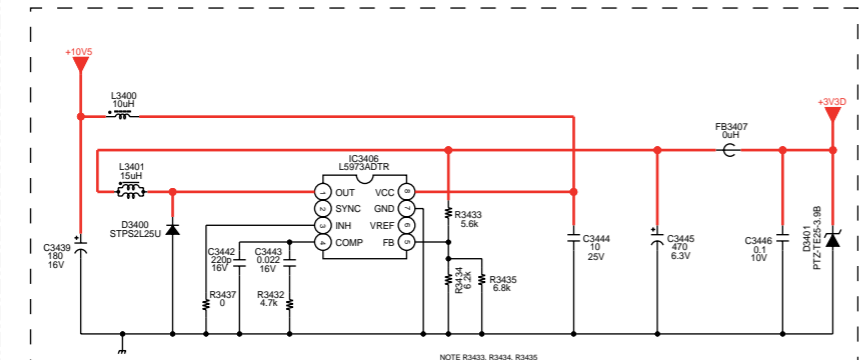

EMMA 3V3 REG

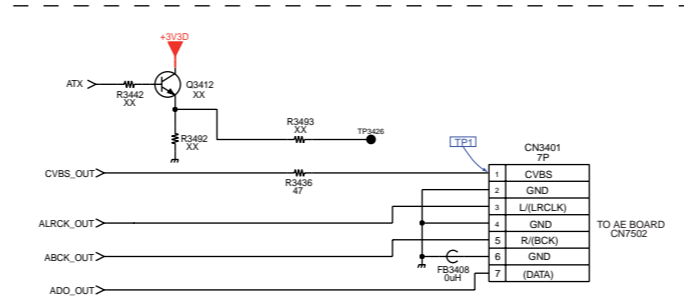

SYSTEM & I2S AUDIO & VIDEO

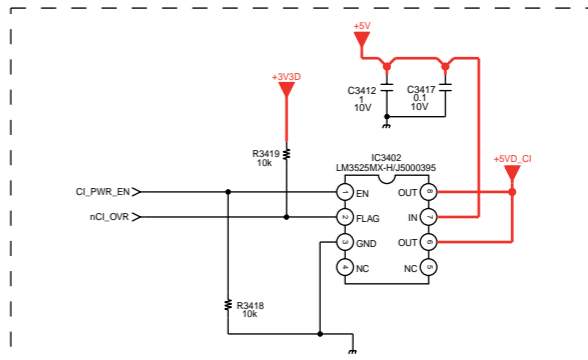

CI POWER SWITCH

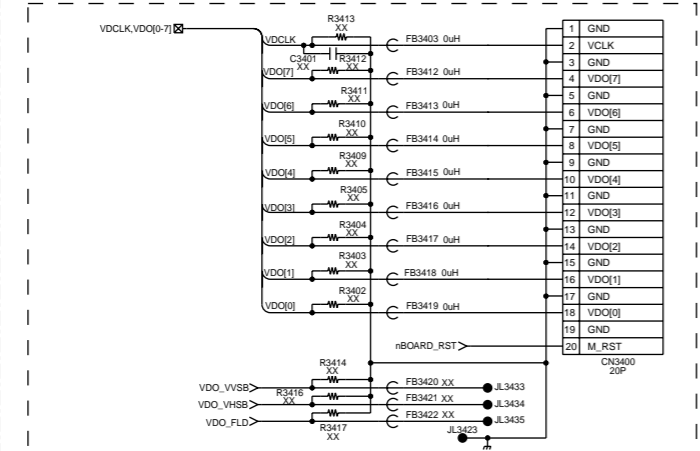

DIGITAL VIDEO OUT

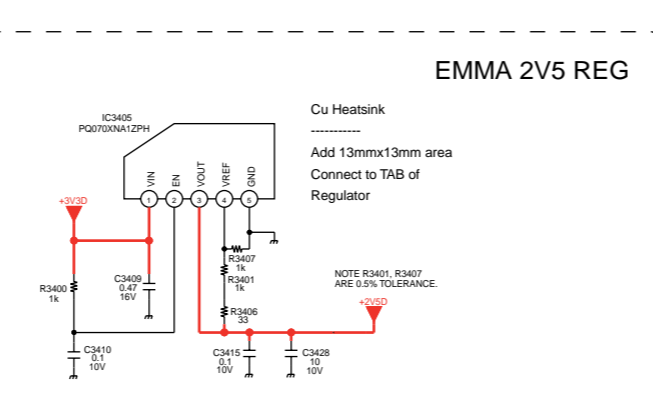

EMMA 2V5 REG

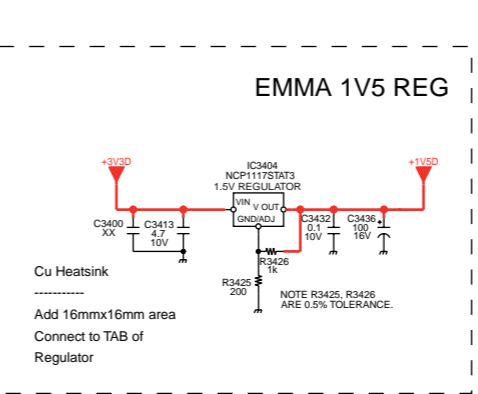

EMMA 1V5 REG

~ FEE (4/6) Board Waveform ~

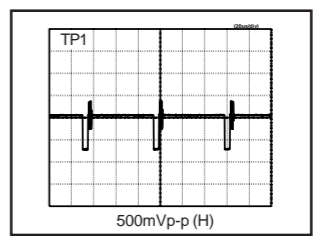

COMPONENTS MARKED AS XX ARE NOT FITTED ON THIS MODEL

A B C D E F G H I J K L M N O

1
2
3
4
5
6
7
8
9
10
11

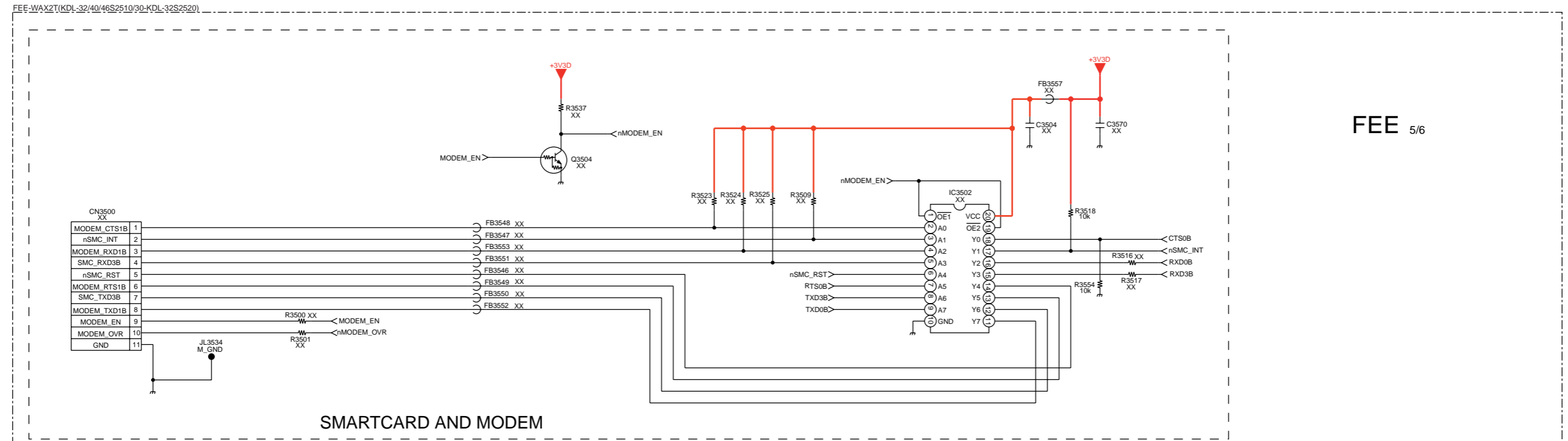

FEE 5/6

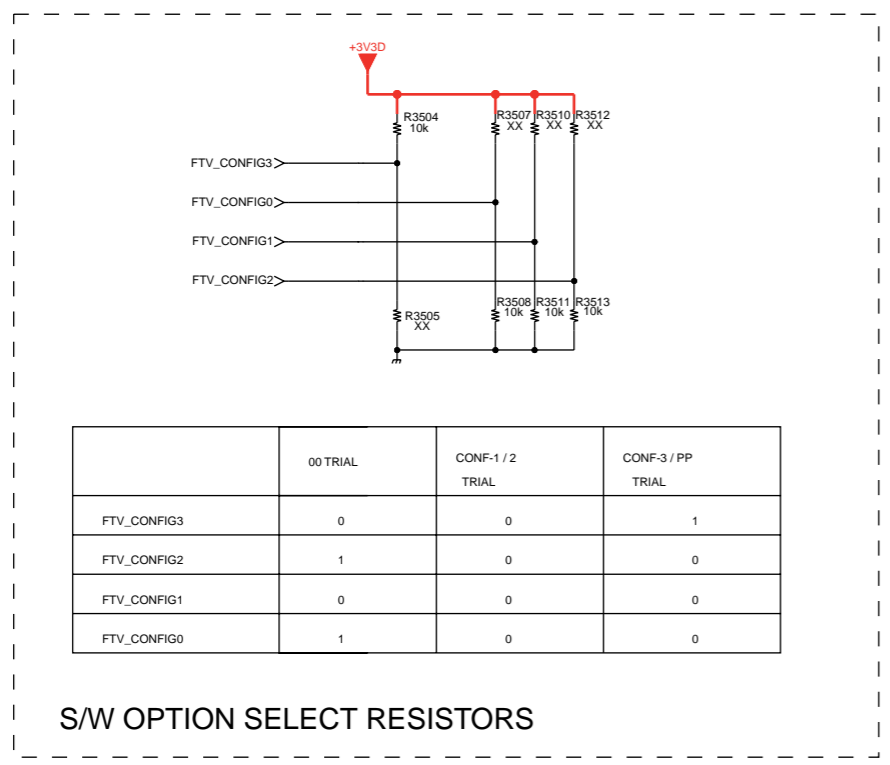

	00 TRIAL	CONF-1 / 2 TRIAL	CONF-3 / PP TRIAL
FTV_CONFIG3	0	0	1
FTV_CONFIG2	1	0	0
FTV_CONFIG1	0	0	0
FTV_CONFIG0	1	0	0

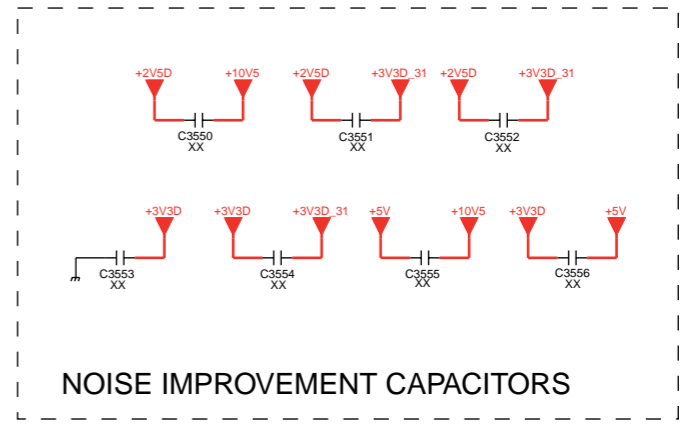
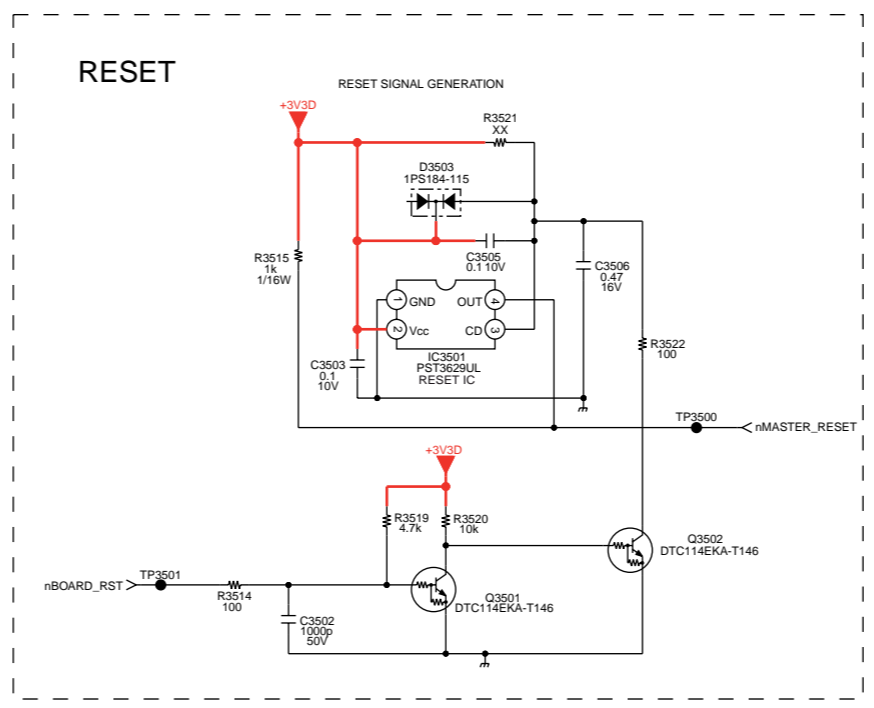

COMPONENTS MARKED AS XX ARE NOT FITTED ON THIS MODEL

A B C D E F G H I J K L M N O

1
2
3
4
5
6
7
8
9
10
11

FEE-WAX2T(KDL-32/40/46S2510/30-KDL-32S2520)

FEE 6/6

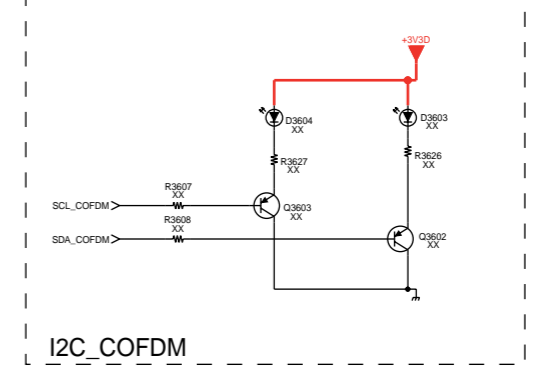
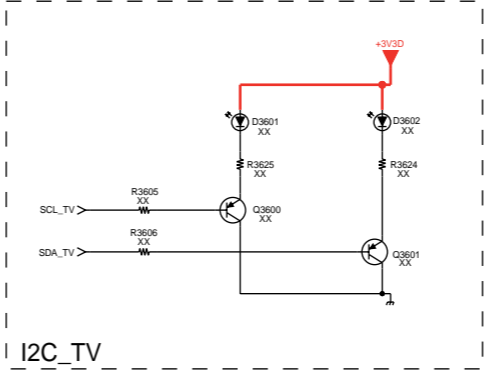
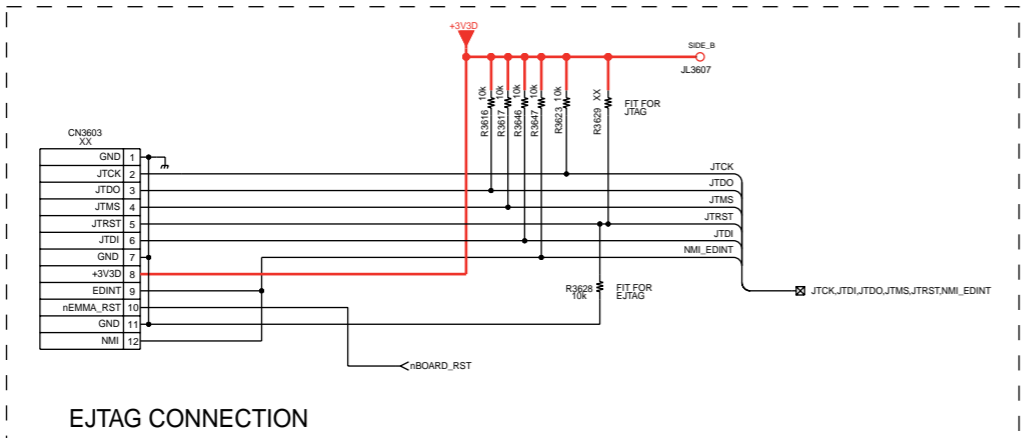
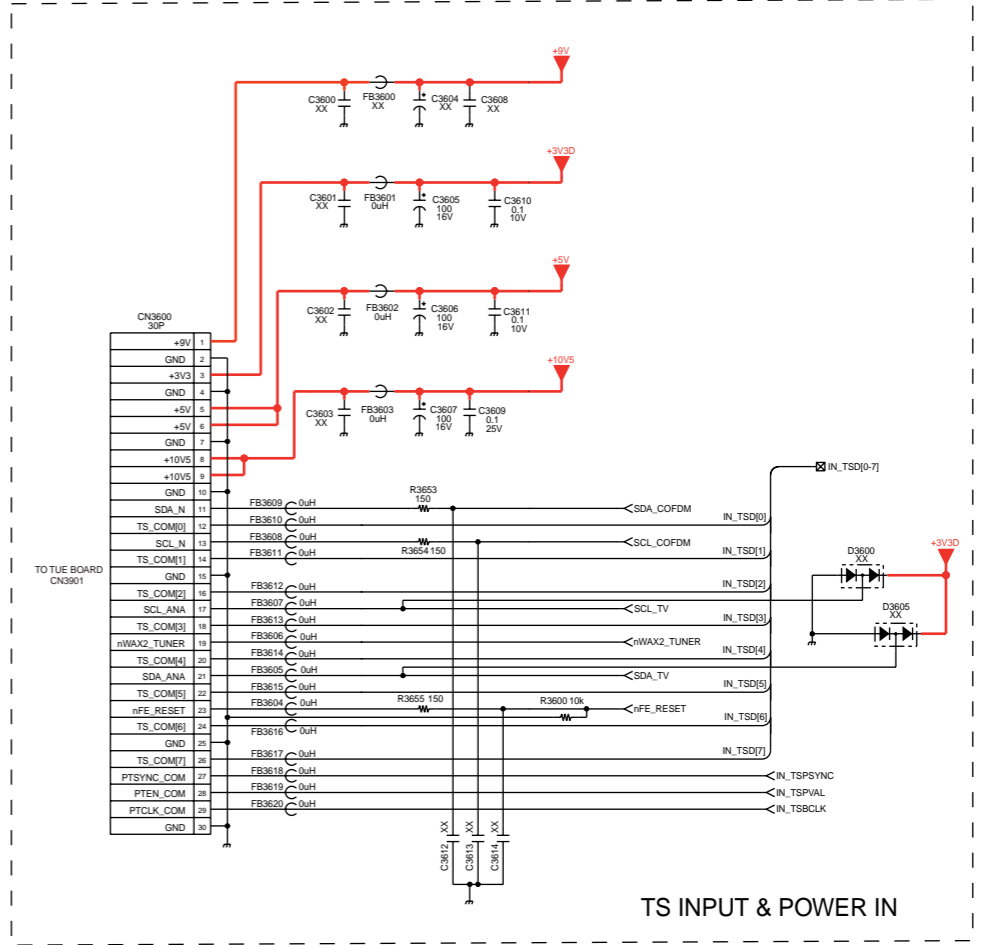
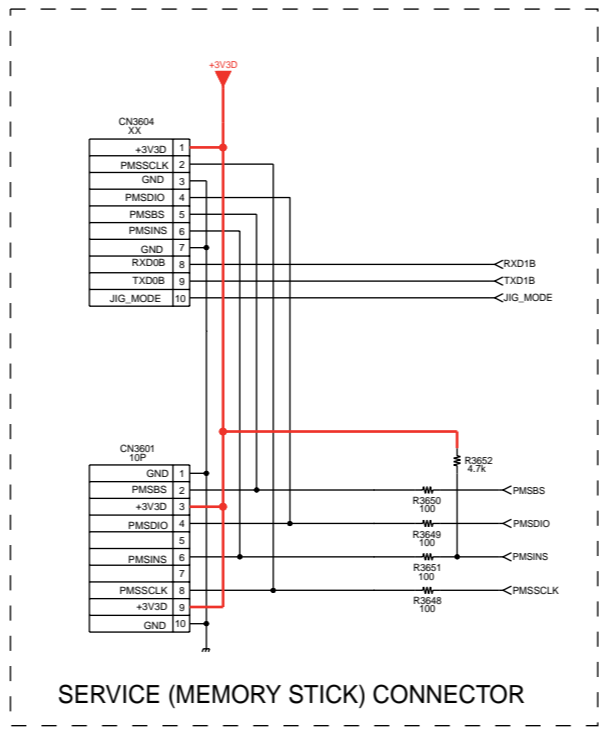
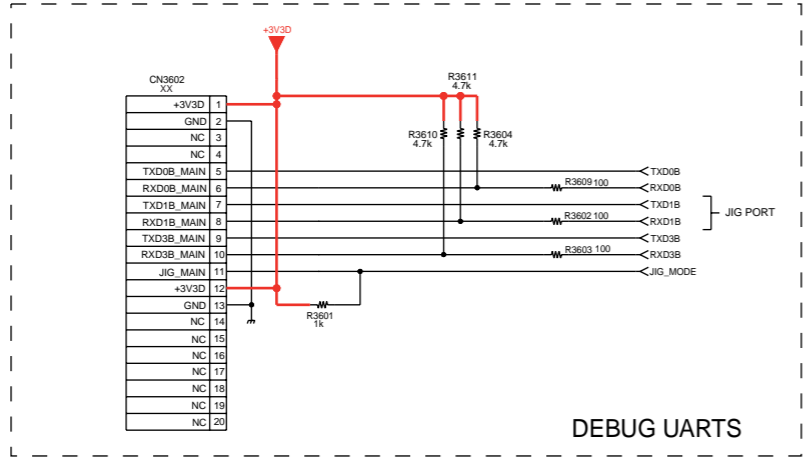
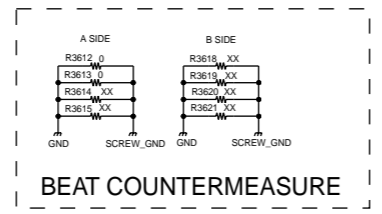
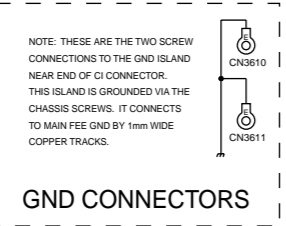

COMPONENTS MARKED AS XX ARE NOT FITTED ON THIS MODEL

A B C D E F G H I J K L M N O

~ FEE Printed Wiring Board Conductor Side A ~

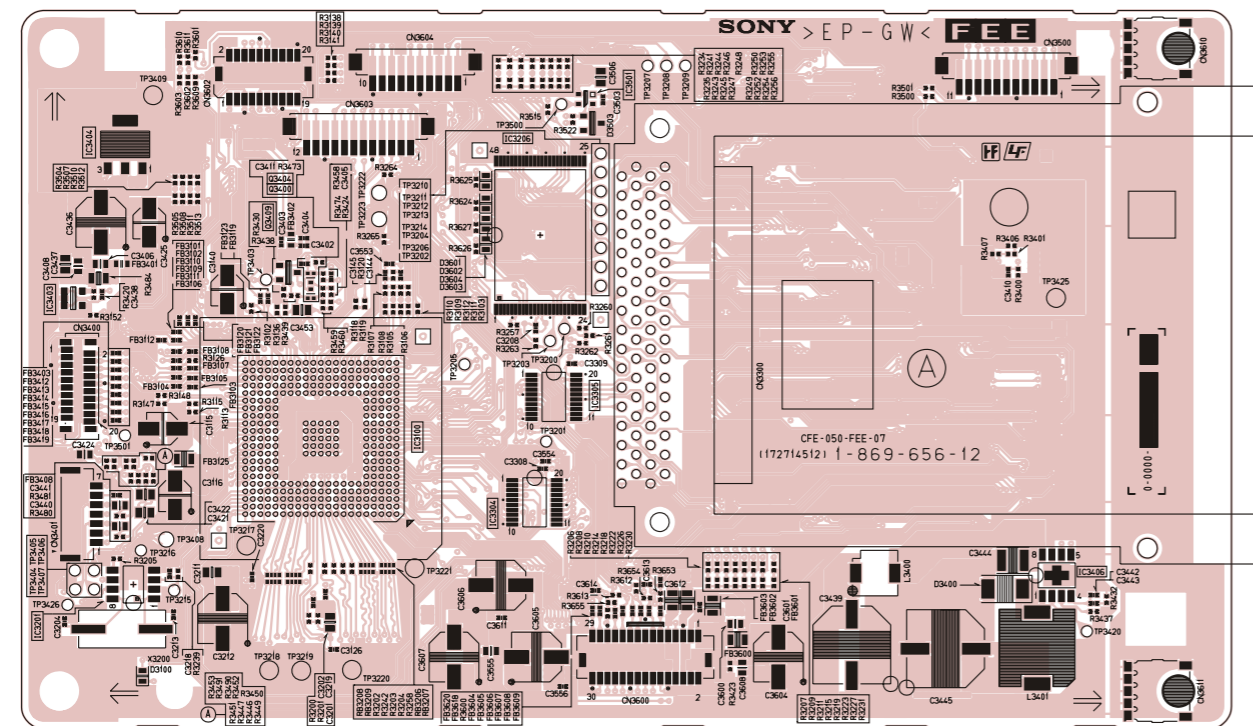

~ FEE Board Semiconductor Voltage Table Side A ~

Ref	(e)(s)	(b)(g)	(c)(d)
Q3409	1.0	0.3	0

~ FEE Board Semiconductor Location Table Side A ~

DIODE	IC	IC3206	C - 2	IC3403	A - 3	IC3501	D - 2
D3400	F - 4	IC3100	C - 3	IC3304	C - 4	TRANSISTOR	
D3503	D - 2	IC3201	A - 4	IC3305	D - 3	IC3406	F - 4
						Q3409	B - 2

~ FEE Board IC Voltage Table Side A ~

Ref No	Pin No	Volts (V)	Ref No	Pin No	Volts (V)	Ref No	Pin No	Volts (V)	Ref No	Pin No	Volts (V)	Ref No	Pin No	Volts (V)			
IC3201	1	1.3	IC3201	4	0	IC3201	8	1.9	IC3404	3	0	IC3406	3	0			
	2	0		5	1.7		IC3404	1		3.3	IC3406		4	1.0	IC3406	7	0
	3	1.7		6-7	3.3			2		1.5			5	1.2		8	13.0

~ FEE Printed Wiring Board Conductor Side B ~

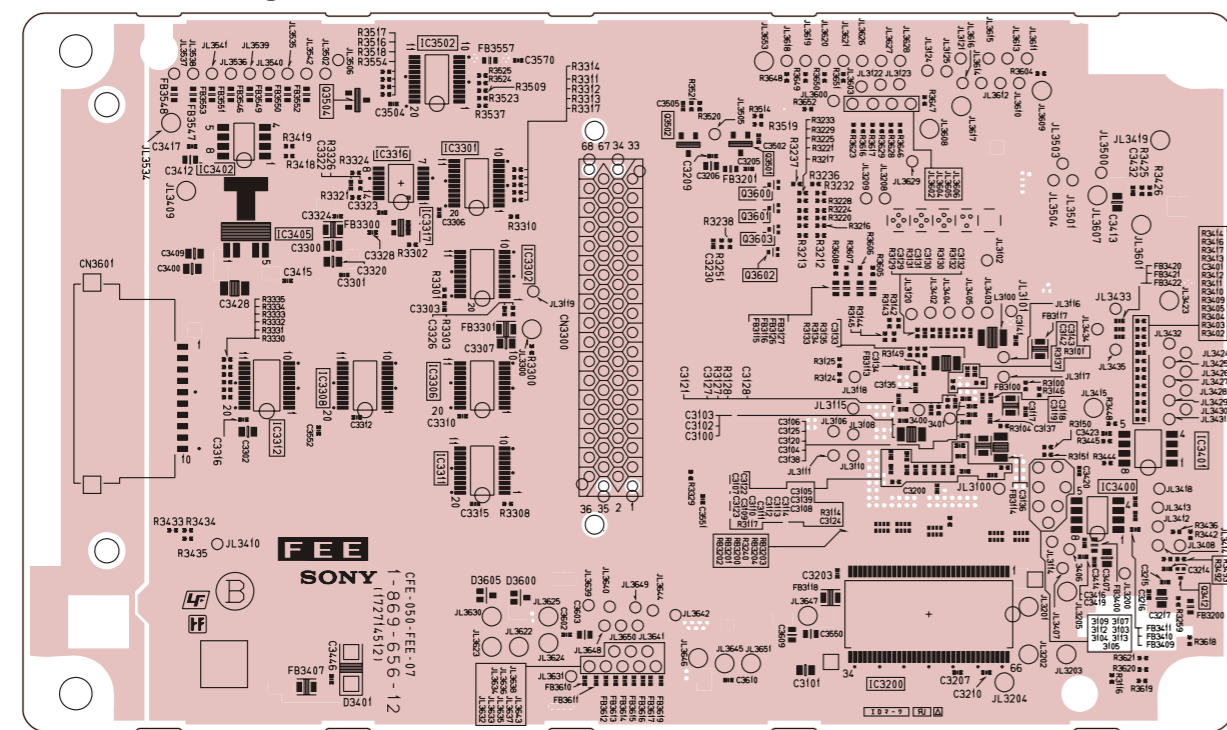

~ FEE Board Semiconductor Location Table Side B ~

DIODE	IC	IC3306	C - 8	IC3316	C - 7	IC3405	B - 8
D3401	B - 10	IC3200	E - 10	IC3308	B - 8	TRANSISTOR	
D3600	C - 10	IC3301	C - 7	IC3311	C - 9	IC3400	F - 9
D3605	C - 10	IC3302	C - 8	IC3312	B - 8	IC3402	B - 7
						Q3501	E - 7
						Q3502	D - 7

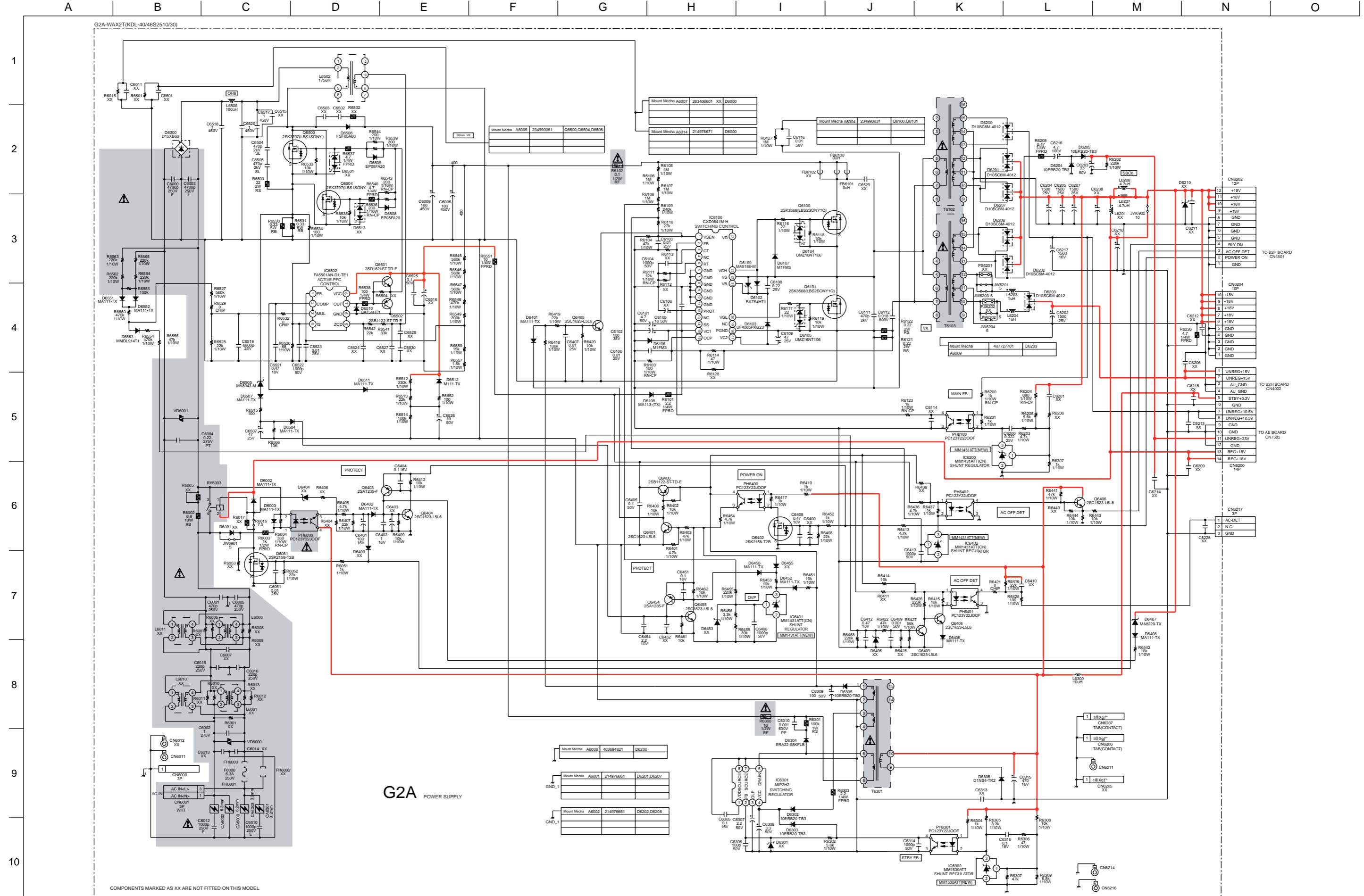

COMPONENTS MARKED AS XX ARE NOT FITTED ON THIS MODEL

G2A POWER SUPPLY

Mount Mecha	A6008	4038094821	D6200
Mount Mecha	A6001	214978661	D6201, D6207
Mount Mecha	A6002	214978661	D6202, D6208

~ G2A Board Schematic Diagram [Power Supply] ~

A B C D E F G H I J K L M N O

~ G2A Printed Wiring Board Conductor Side A ~

~ G2A Board Semiconductor Location Table Side A ~

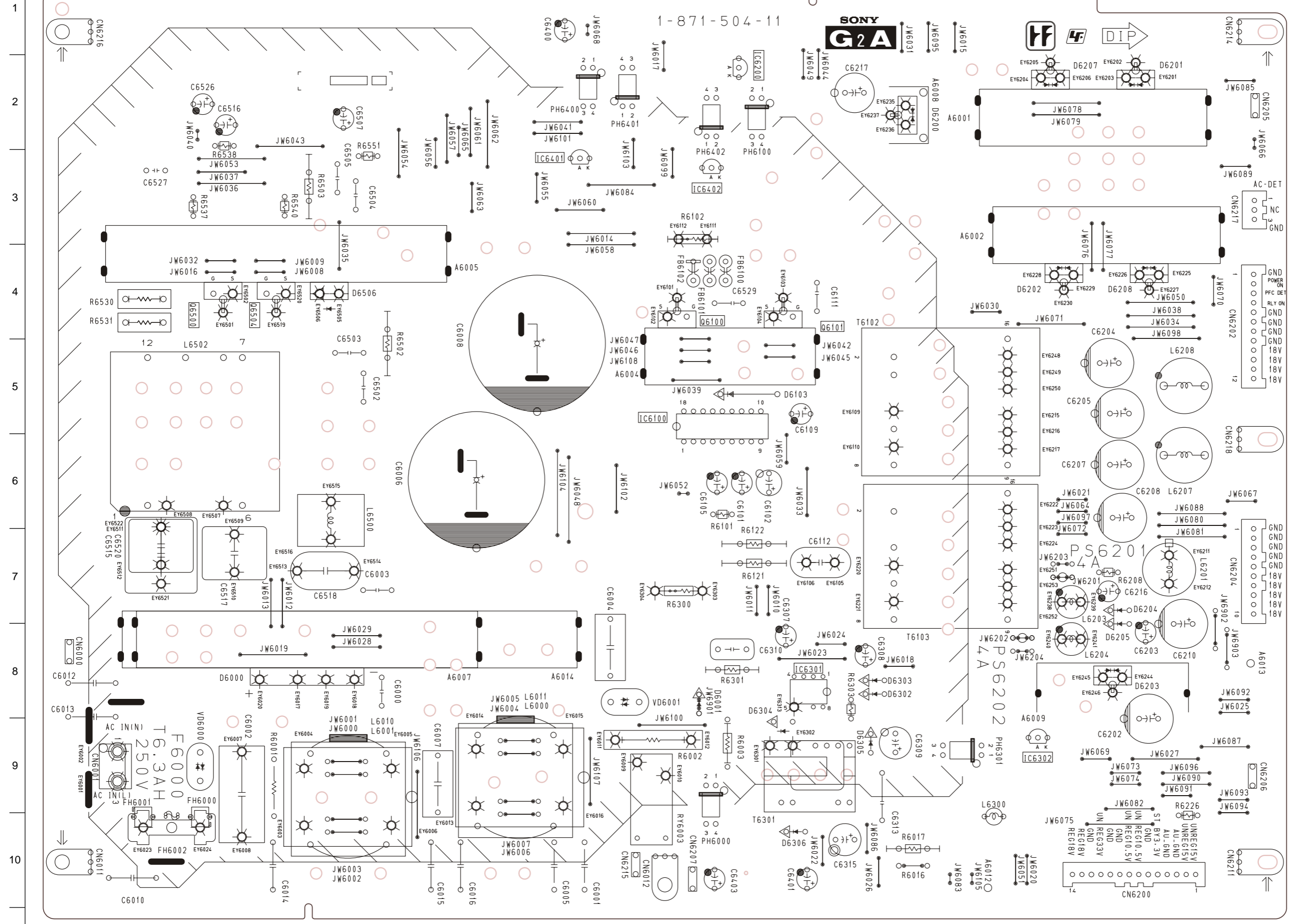

DIODE		IC		TRANSISTOR	
D6000	C - 8	D6305	I - 9	Q6100	H - 4
D6103	H - 5	D6306	H - 10	Q6101	I - 4
D6200	J - 2	D6506	D - 4	Q6500	B - 4
D6201	M - 2			Q6504	C - 4
D6202	K - 4				
D6203	L - 8				
D6204	L - 7				
D6205	K - 8				
D6207	L - 2				
D6208	L - 8				
D6302	J - 8				
D6303	J - 8				
D6304	H - 8				

11

A B C D E F G H I J K L M N O

~ G2A Printed Wiring Board Conductor Side B ~

~ G2A Board Semiconductor Location Table Side B ~

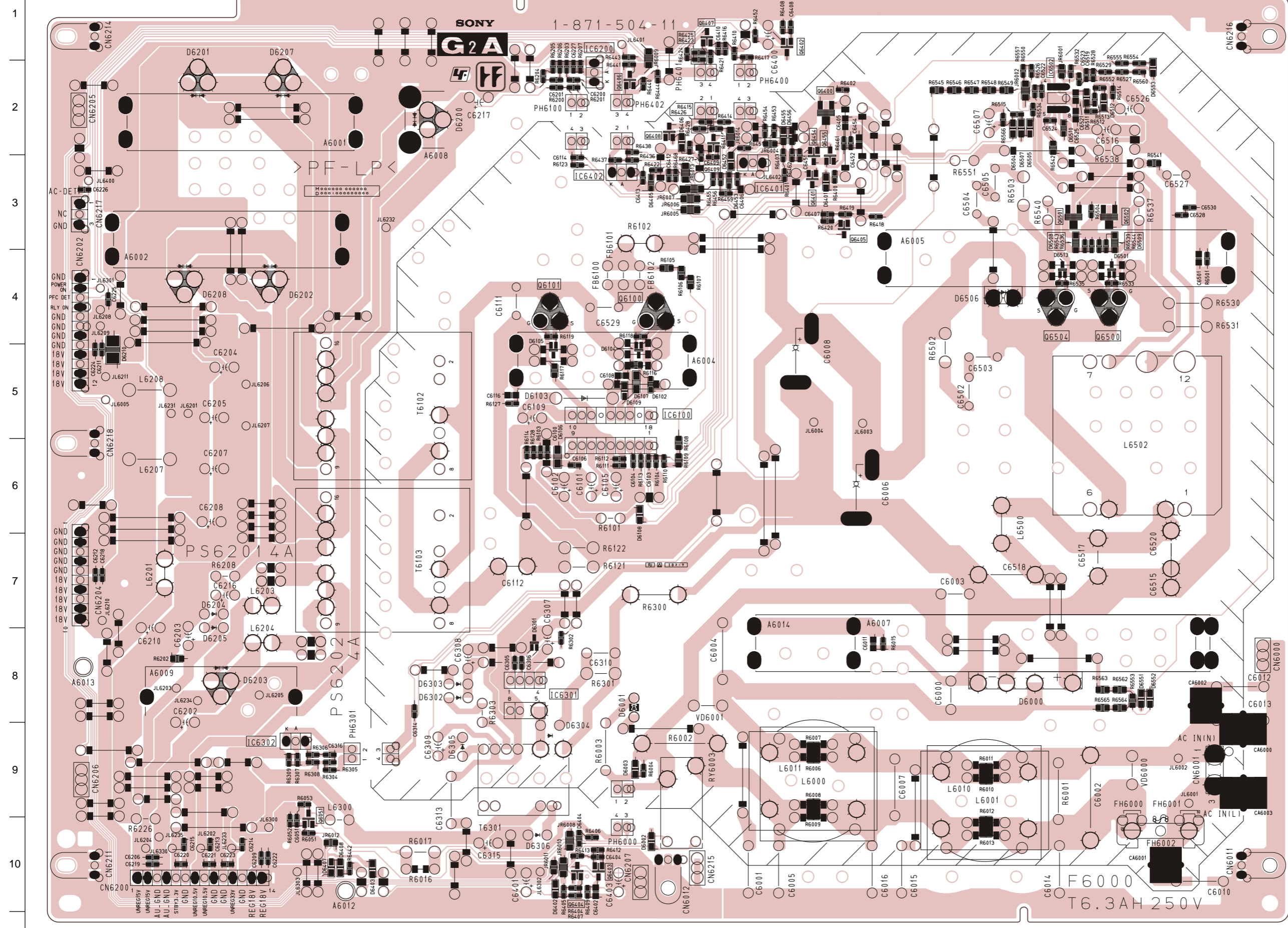

DIODE			
D6000	K - 8	D6507	K - 3
D6002	G - 10	D6508	K - 3
D6003	G - 9	D6509	L - 3
D6102	G - 5	D6510	L - 2
D6103	F - 5	D6511	L - 2
D6104	G - 5	D6512	L - 2
D6105	F - 5	D6551	L - 8
D6106	F - 5	D6552	L - 8
D6107	G - 5	IC	
D6108	G - 6	IC6100	G - 5
D6200	E - 2	IC6200	G - 2
D6201	B - 2	IC6301	F - 8
D6202	C - 4	IC6302	C - 9
D6203	C - 8	IC6401	H - 3
D6204	B - 7	IC6402	F - 3
D6205	B - 8	IC6502	K - 2
D6207	C - 2	TRANSISTOR	
D6208	B - 4	Q6051	C - 10
D6302	E - 8	Q6100	G - 4
D6303	E - 8	Q6101	F - 4
D6304	F - 9	Q6400	I - 2
D6305	E - 9	Q6401	I - 3
D6306	F - 10	Q6402	I - 2
D6401	I - 3	Q6403	F - 10
D6402	F - 10	Q6404	F - 10
D6407	D - 10	Q6405	I - 3
D6408	D - 10	Q6406	G - 2
D6452	H - 3	Q6454	I - 2
D6456	I - 2	Q6455	I - 2
D6504	K - 3	Q6500	L - 4
D6505	K - 3	Q6501	K - 3
D6506	J - 4	Q6502	L - 3
		Q6504	K - 4

A B C D E F G H I J K L M N O

1
2
3
4
5
6
7
8
9
10
11

~ H1E Board Schematic Diagram [Switch Panel] ~

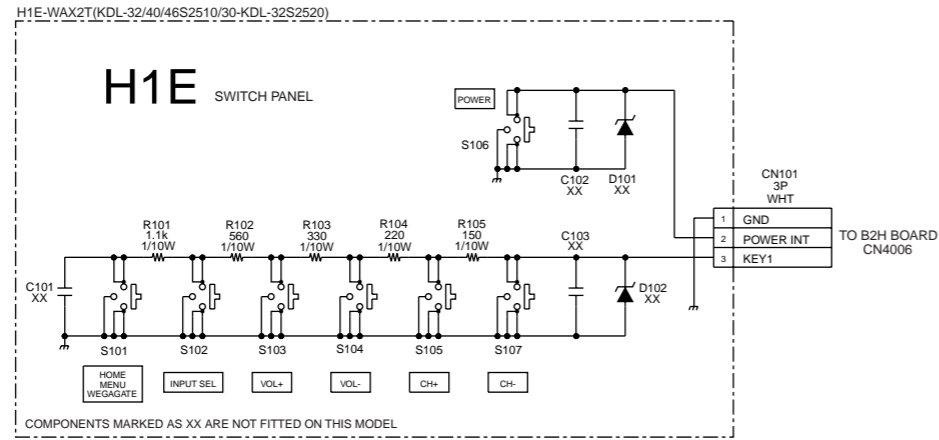

~ H2E Board Schematic Diagram [AV I/O] ~

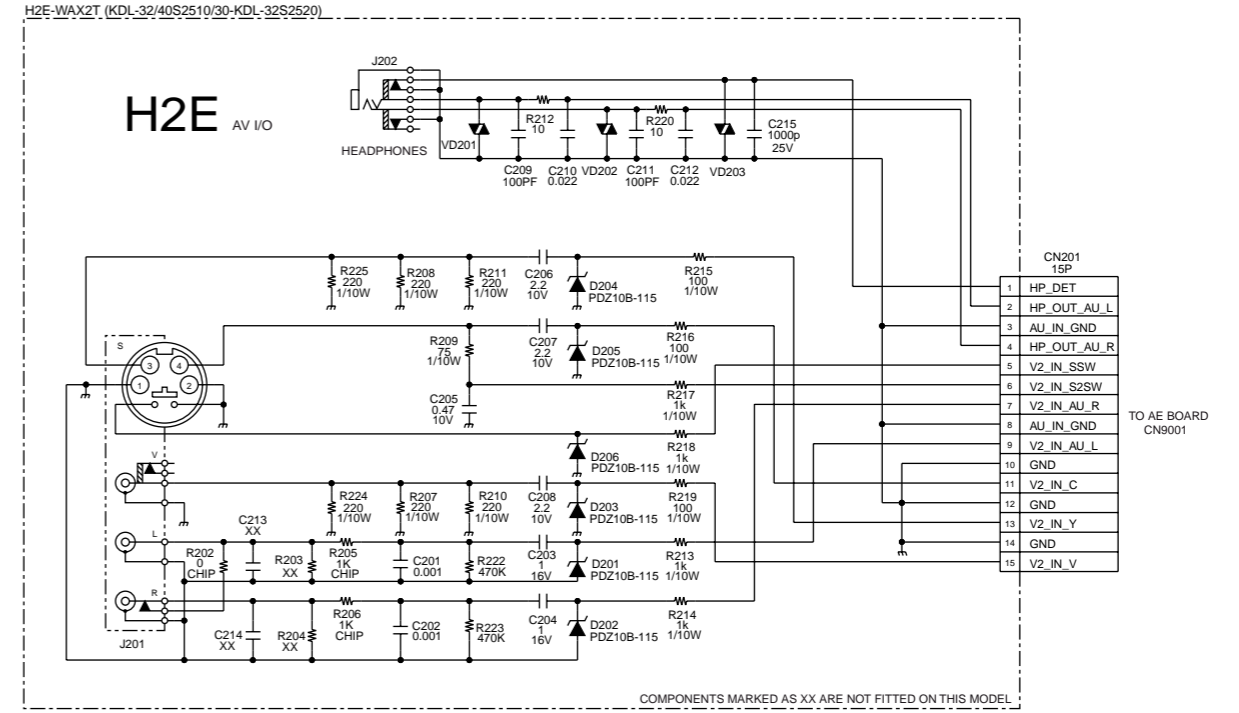

~ H3E Board Schematic Diagram [Led, Sircs] ~

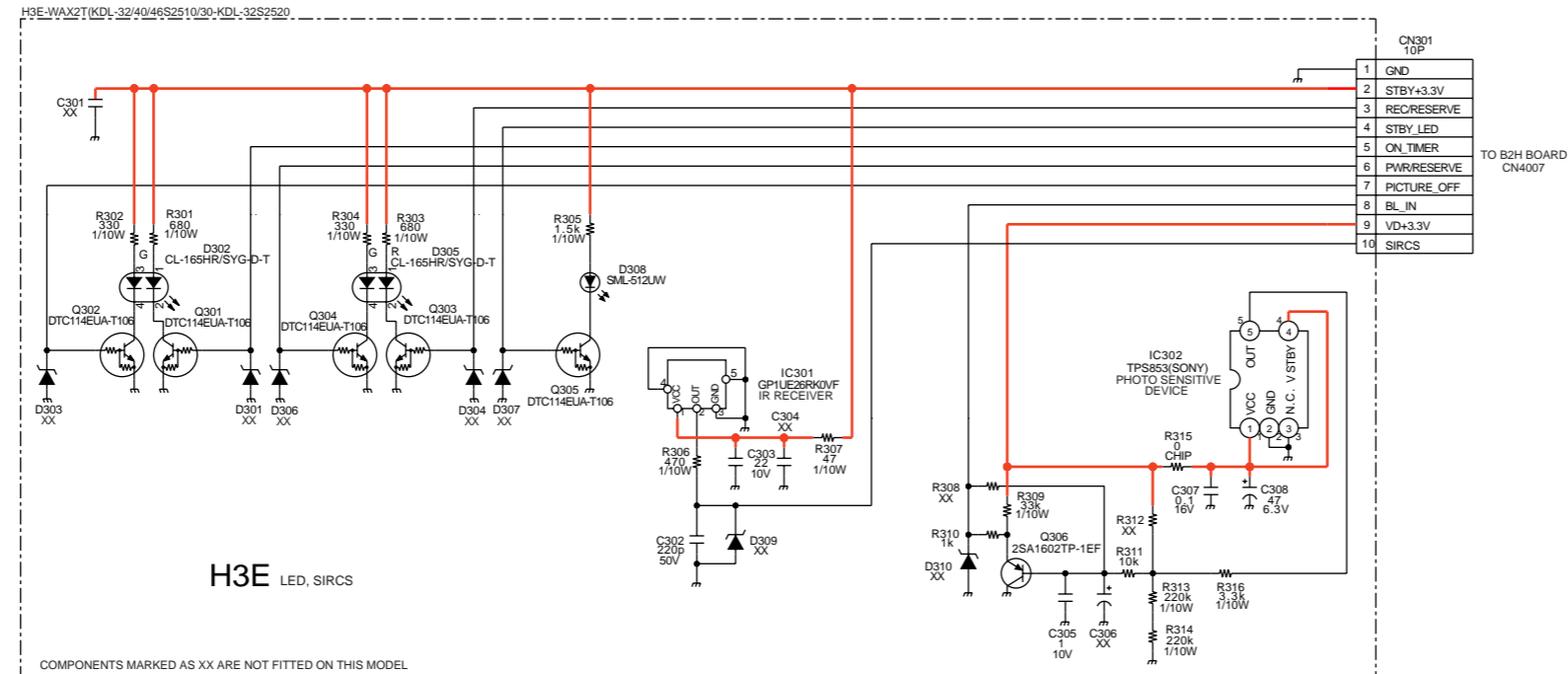

A B C D E F G H I J K L M N O

1
2
3
4
5
6
7
8
9
10
11

~ H46E Board Schematic Diagram [AV I/O] ~

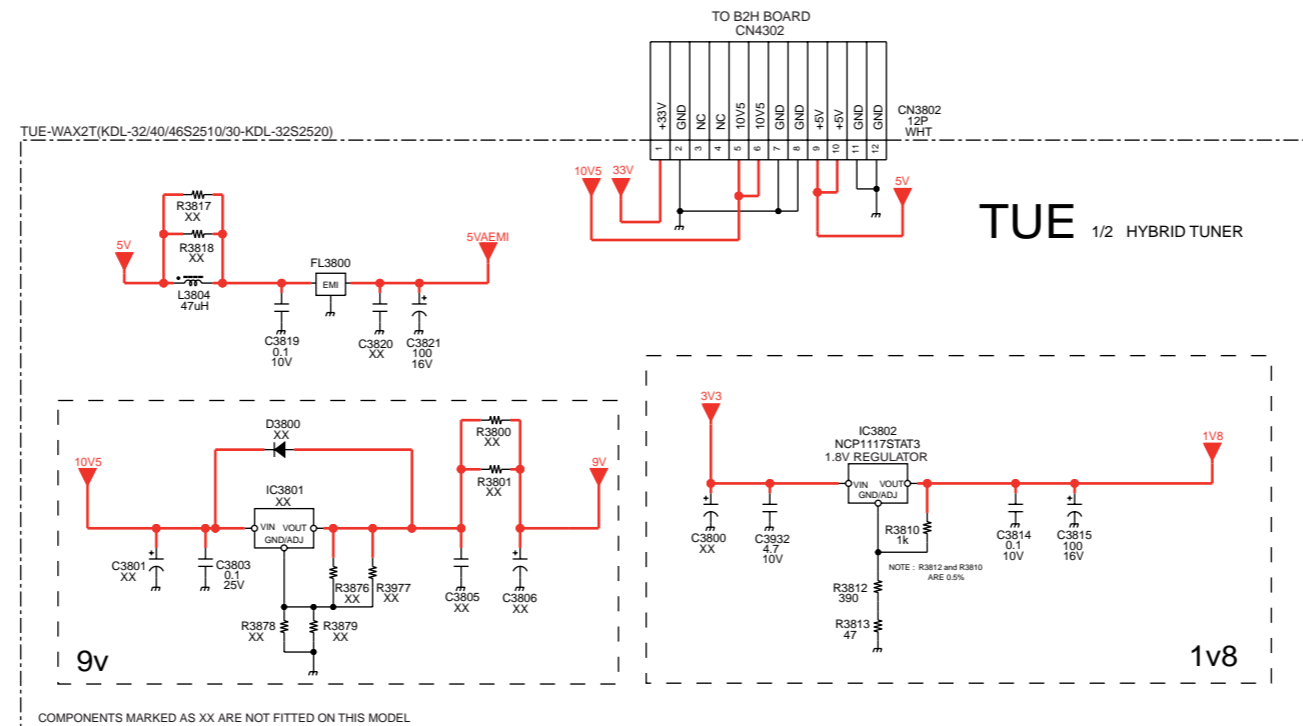
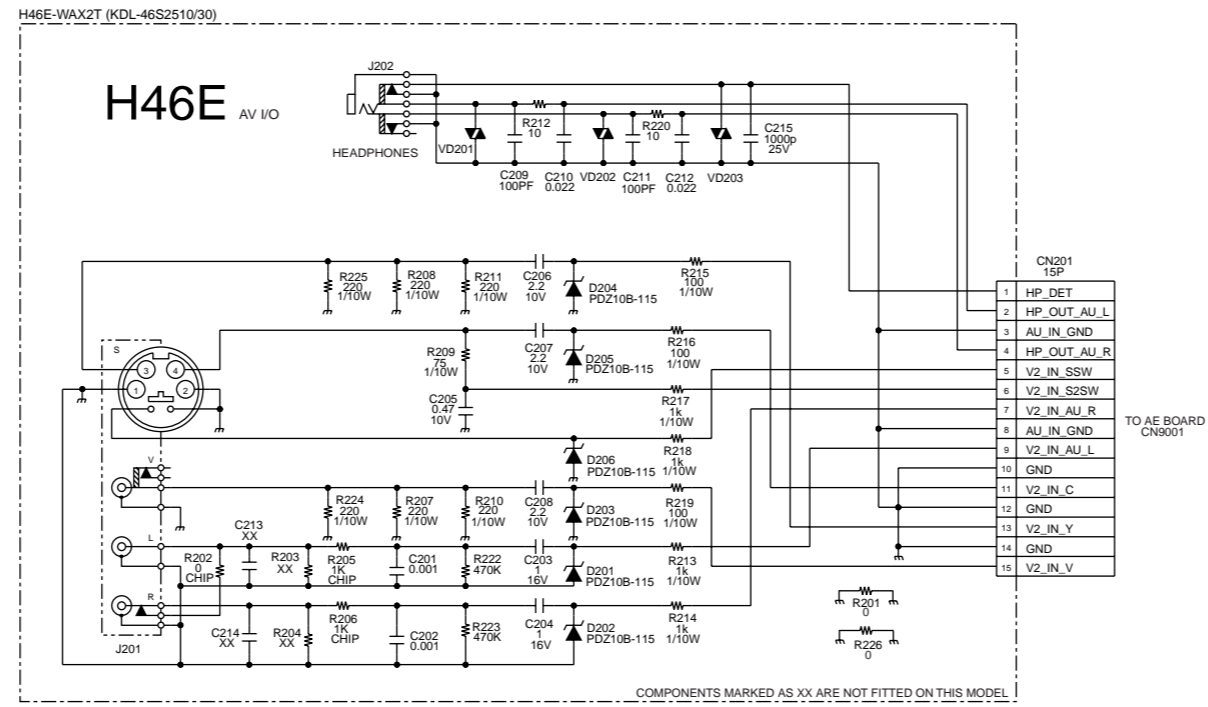

~ TUE Board Schematic Diagram [Hybrid Tuner] Page 1/2 ~

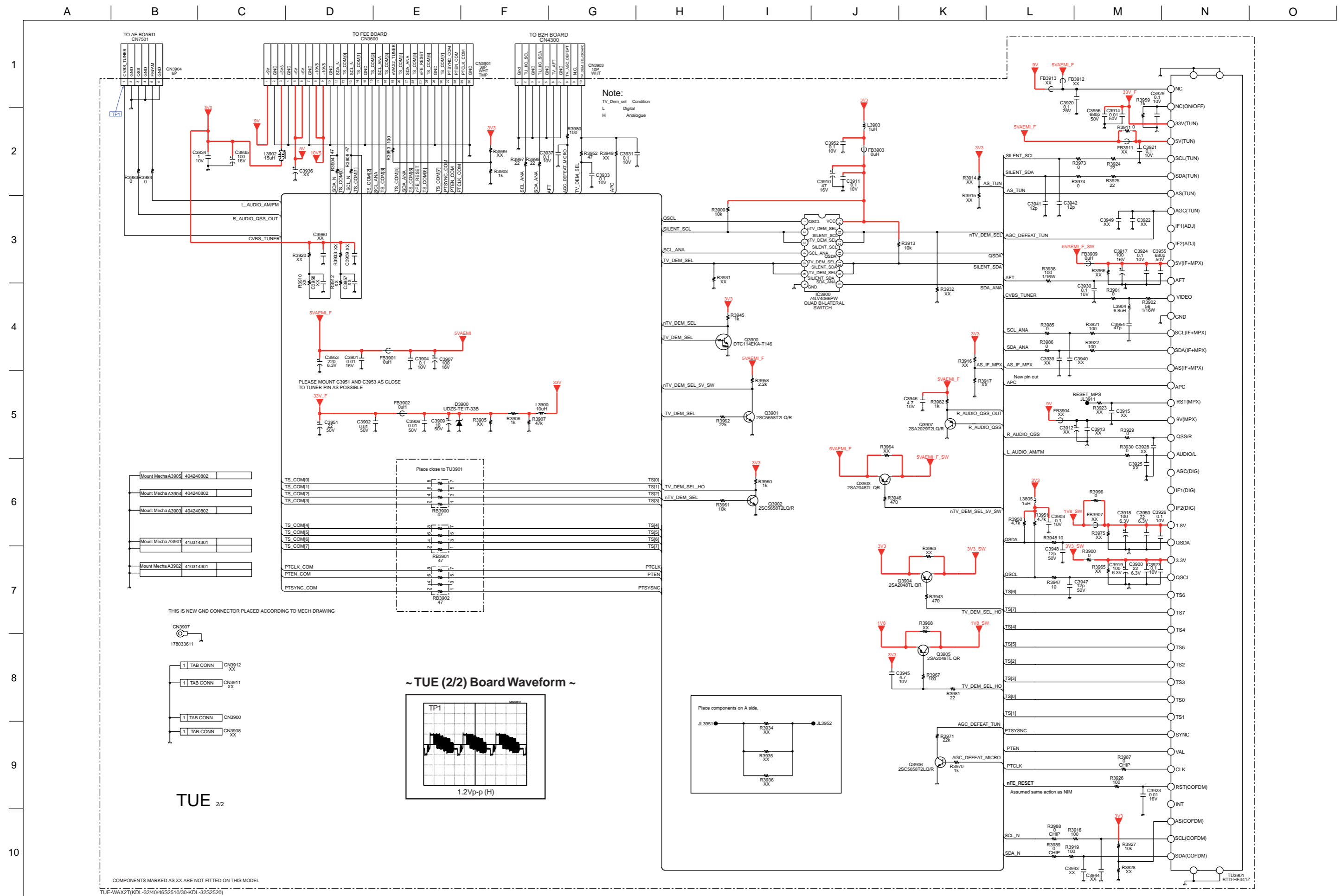

A B C D E F G H I J K L M N O

1
2
3
4
5
6
7
8
9
10
11

~ TUE Printed Wiring Board Conductor Side A ~

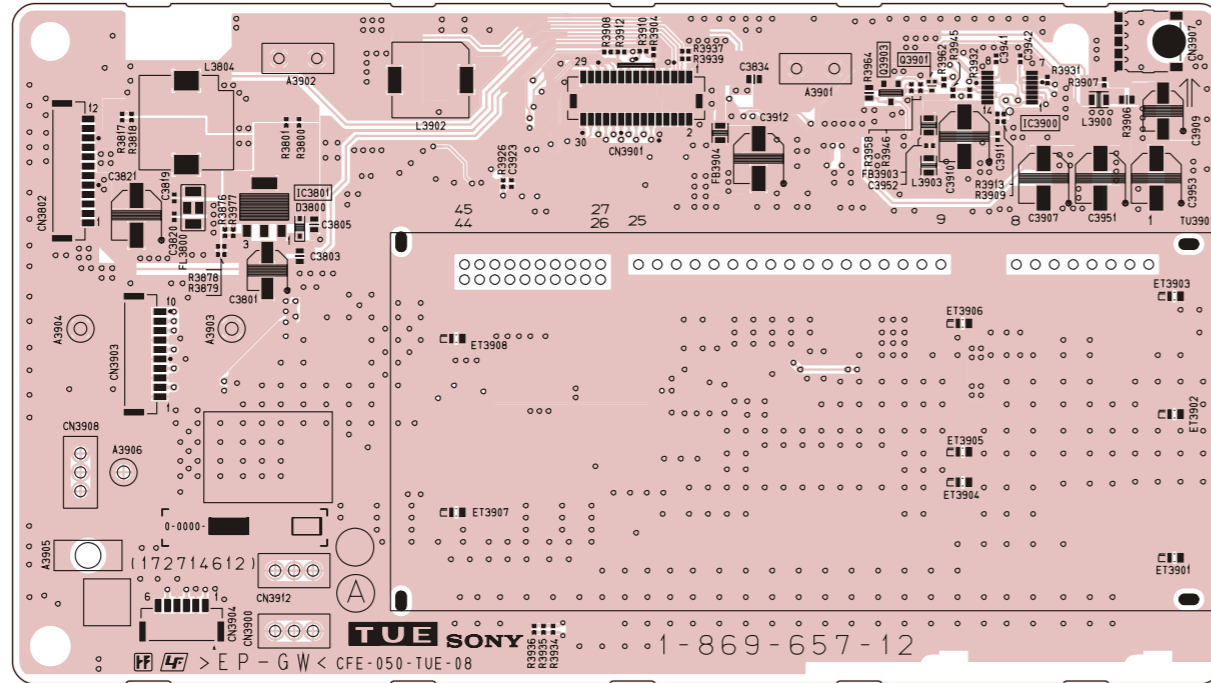

~ TUE Board Semiconductor Location Table Side A ~

IC		TRANSISTOR	
IC3900	G - 3	Q3901	G - 2
		Q3903	F - 2

~ TUE Board Semiconductor Voltage Table Side A ~

Ref	(e)(s)	(b)(g)	(c)(d)
Q3900	0	3.2	0
Q3901	0	0.7	0
Q3903	4.9	4.2	4.9

~ TUE Board IC Voltage Table Side A ~

Ref No	Pin No	Volts (V)	Ref No	Pin No	Volts (V)
IC3900	1-4	3.3	IC3900	8-11	3.3
	5-6	3.2		12-13	0
	7	0		14	3.3

~ TUE Printed Wiring Board Conductor Side B ~

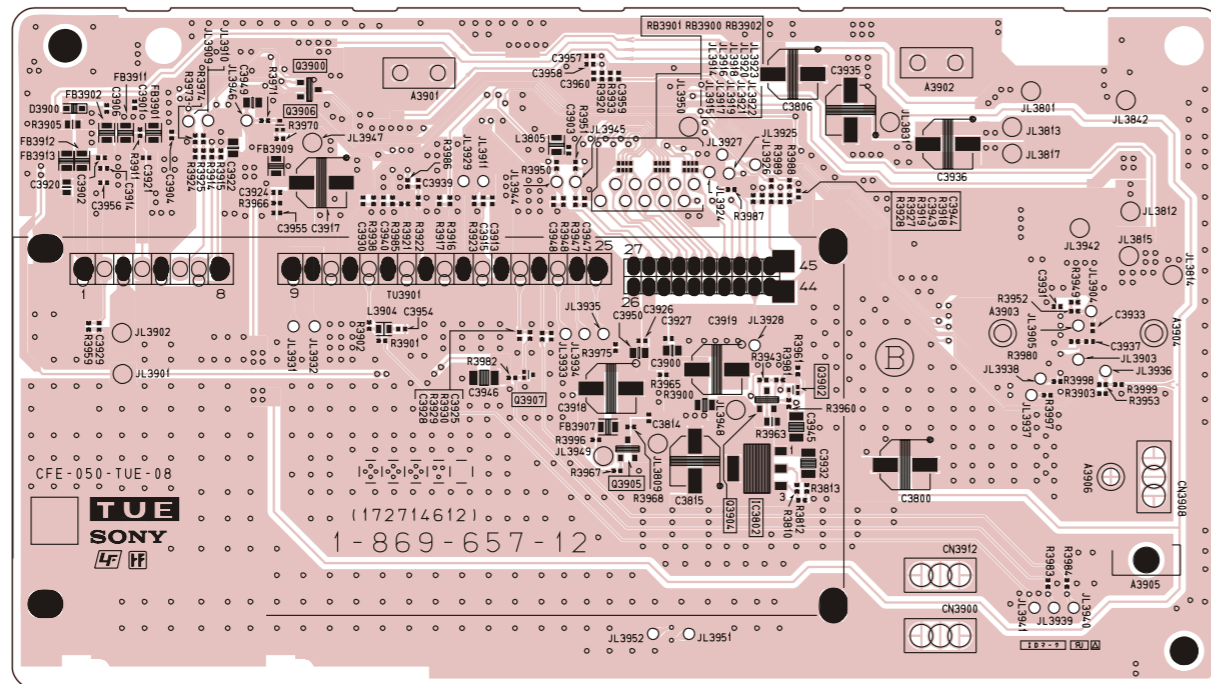

~ TUE Board Semiconductor Location Table Side B ~

DIODE		TRANSISTOR			
D3900	B - 8	Q3900	C - 8	Q3905	E - 10
		Q3902	F - 9	Q3906	C - 8
				Q3907	D - 9
IC3802	F - 10	Q3904	F - 10		

4-4. SEMICONDUCTORS

74LVC14APW
74LVC4066PW
74LVC541APW

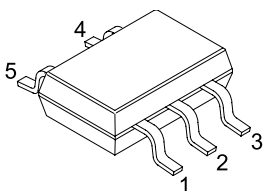

CXD9199GG-D

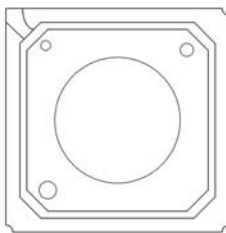

LM3525MX-H/J5000395

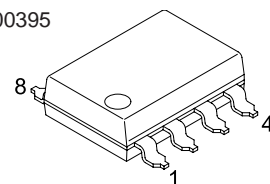

74LVT245PW-T

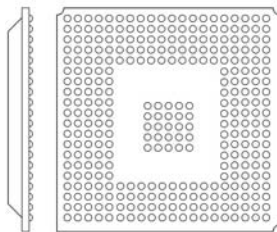

LM393DT (A)

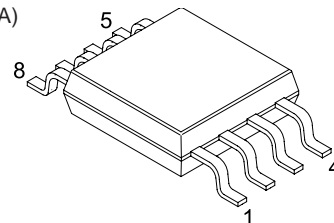

BA09FP-E2

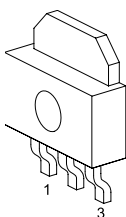

CXD9841M

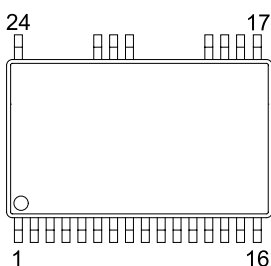

M24256-BWMN6T

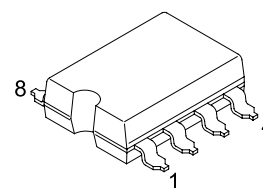

BD9775FV

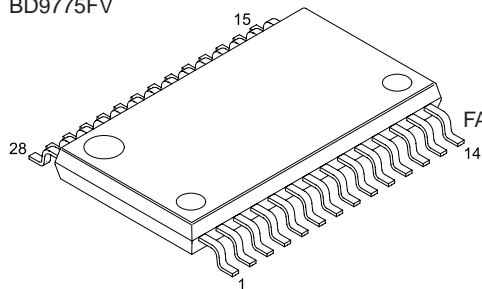

FA5501AN-D1-TE1

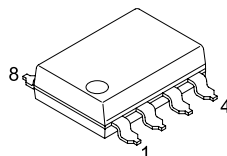

M24C02-WMN6T(B)

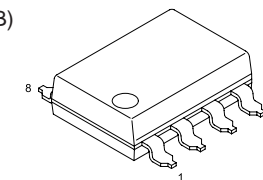

M61571AFP-DF0T

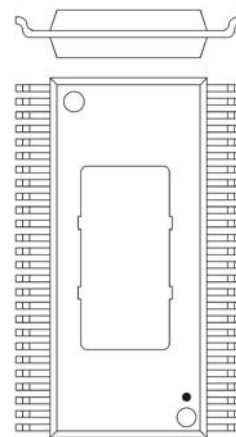

BR24L02F-WE2

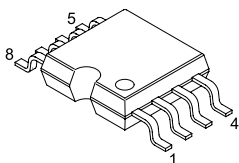

GP1UE26RK0VF

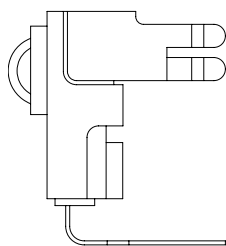

CS4335-KSZR

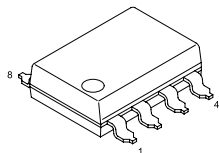

ICS7150MLFT

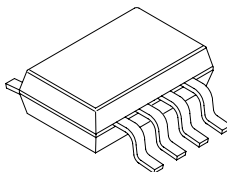

MB91305PMC-G-BNDE1

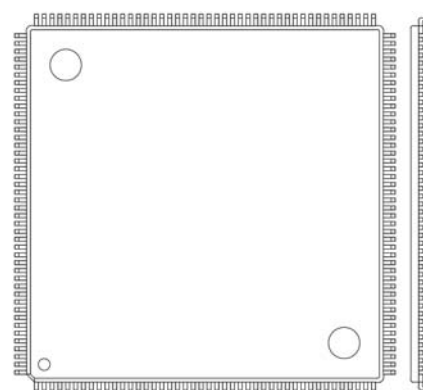

CXA2069Q-TL

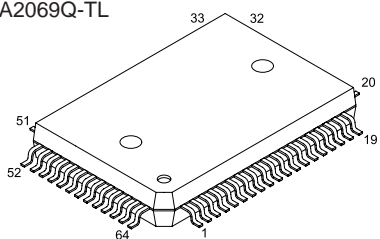

K9F2808U0C-PCB0T

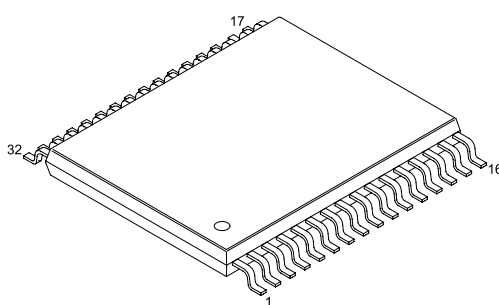

MIP2H2

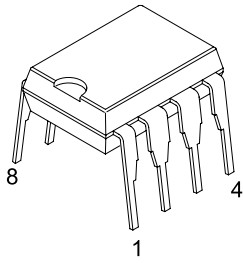

PCA9517DP.118

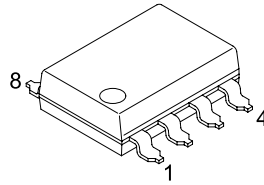

SI8008TM-TL

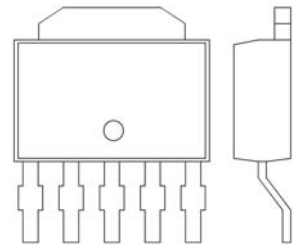

MM1431ATT(CN)
MM1530ATT

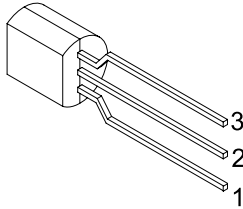

PQ070XNA1ZPH

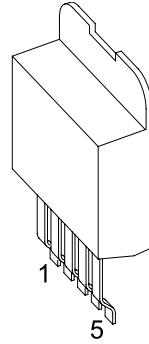

SN74CBTLV3245APWR

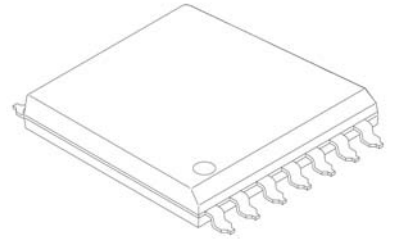

MM1662FTRE

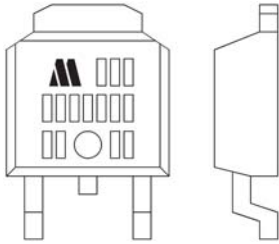

PST3629UL

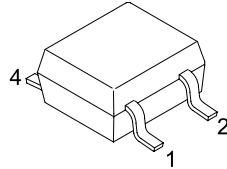

SN74LV132APWR
SN74LVC2G04DCKR

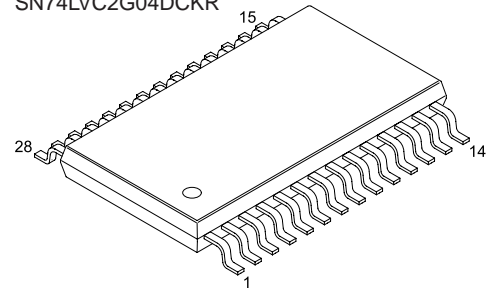

MSP4410K-QA-D6-501

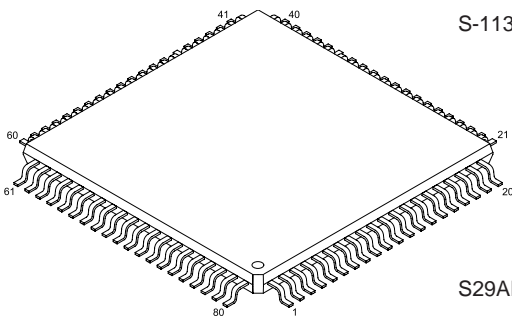

S-1132B18-M5T1G

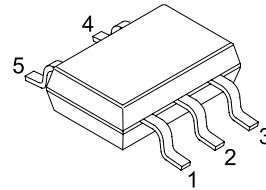

TC7SH00FU (T5RSOYJF)
TC7SH86FU (T5RSOYJF)

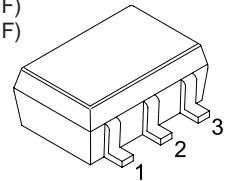

NCP1117STAT3

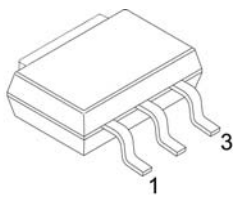

S29AL016D70TFIO10-WAX2E1

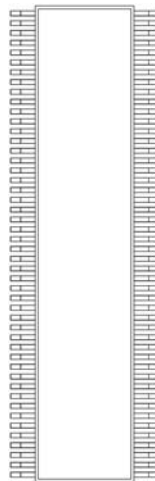

TMP75AIDR

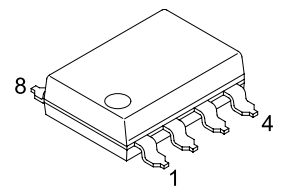

NJM3414AV(TE2)

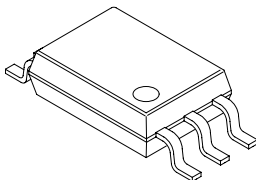

UDP61123F1-100-KA3-A

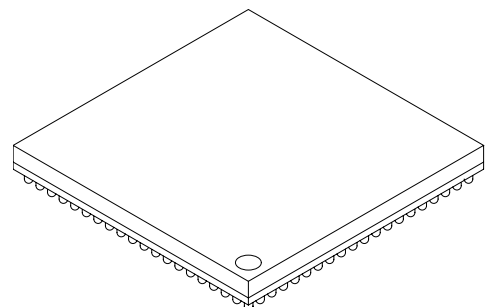

NJM4558V-TE2

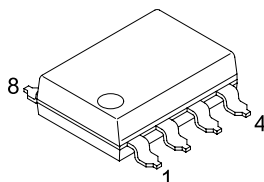

S-35390A-J8T1G

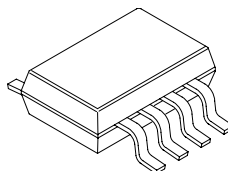

SECTION 5 EXPLODED VIEWS

NOTE :

- Items with no part number and no description are not stocked because they are seldom required for routine service.
- The construction parts of an assembled part are indicated with a collation number in the remarks column.
- Items marked “*” are not stocked since they are seldom required for routine service. Some delay should be anticipated when ordering these items.

Note : Les composants identifiés par une trame et par une marque Δ sont d'une importance critique pour la sécurité. Ne les remplacer que par des pièces du numéro spécifié.

Note : The components identified by shading and marked Δ are critical for safety. Replace only with the part numbers specified in the parts list.

5-1. CHASSIS

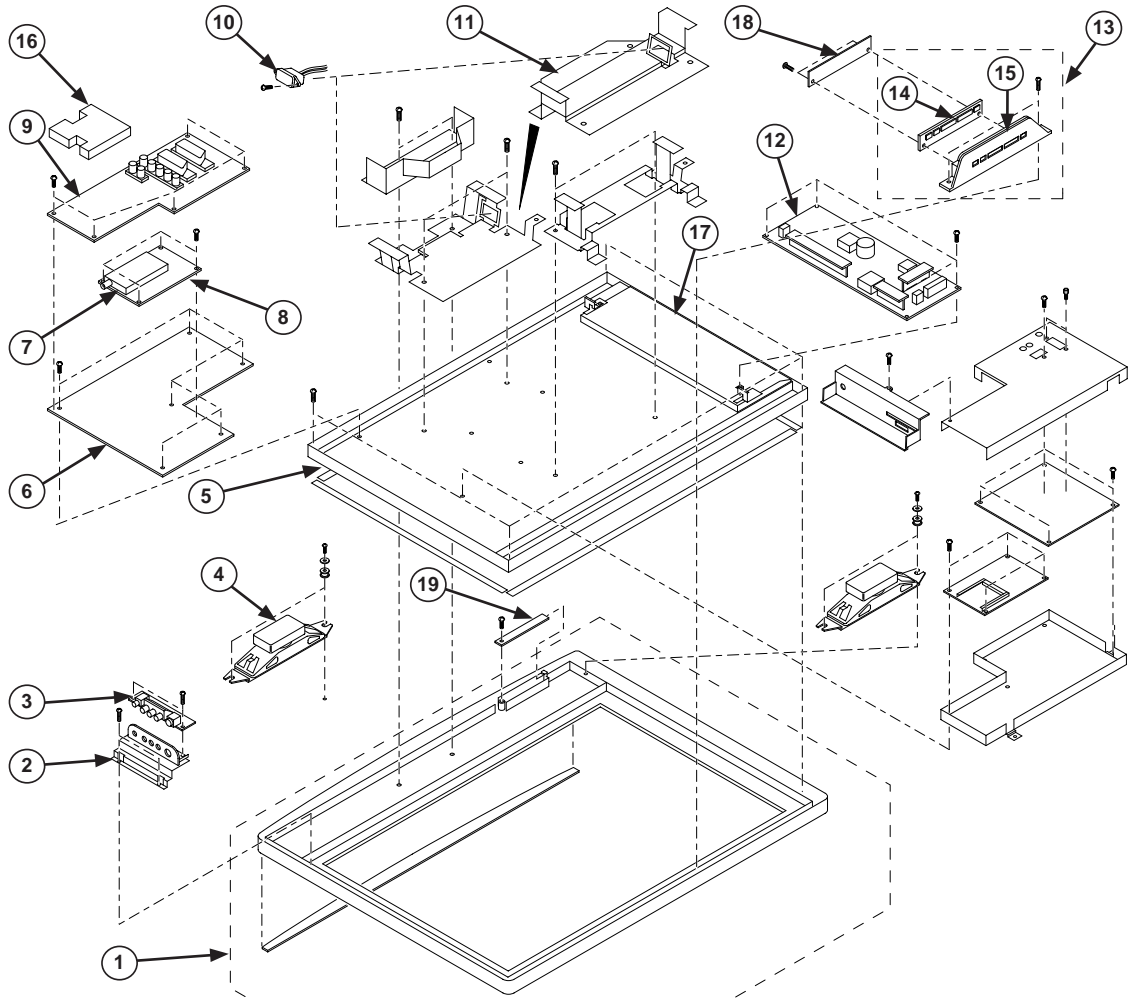

REF.NO.	PART.NO	DESCRIPTION	REMARK	REF.NO.	PART.NO	DESCRIPTION	REMARK
1	X-2148-708-2	BEZEL ASSY (32) (32S2510 UK/AEP)		6	*X-2109-046-4	BRACKET, (A, TU) (C) ASSY	
	X-2148-707-2	BEZEL ASSY (32) (32S2520 UK/AEP)		7	8-597-598-00	TUNER UNIT, DIGITAL BTD-HF441Z	
	X-2159-783-1	BEZEL ASSY (32) (32S2530 UK/AEP)		8	*A-1173-184-C	TUE BOARD COMPLETE WAX2	
	X-2109-271-5	BEZEL ASSY (40) (40S2510 UK/AEP)		9	*A-1144-539-D	AE BOARD COMPLETE	
	X-2159-784-1	BEZEL ASSY (40) (40S2530 UK/AEP)		10	Δ 1-819-729-14	INLET, AC (WITH NOISE FILTER)	
	X-2109-262-5	BEZEL ASSY (46) (46S2510 UK/AEP)		11	X-2109-168-4	BOTTOM FRAME (L) ASSY (40/46S2510/S2530 UK/AEP)	
	X-2159-785-1	BEZEL ASSY (46) (46S2530 UK/AEP)		12	*1-468-980-21	G1 BOARD COMPLETE	
2	*2-663-985-71	HOLDER, SIDE JACK (M)	(32S2510/S2520/S2530 UK/AEP)		*A-1184-357-B	G2A BOARD COMPLETE (40/46S2510/S2530 UK/AEP)	
	*2-663-986-21	HOLDER, SIDE JACK (L) (40/46S2510/S2530 UK/AEP)		13	X-2109-049-3	BUTTON, MULTI (C) ASSY	14, 15
3	*A-1152-233-D	H2E BOARD COMPLETE (KDL-32S2510/S2520/S2530/40S2510/S2530 UK/AEP)		14	2-663-977-01	BUTTON, MULTI	
	*A-1192-084-B	H46E BOARD COMPLETE (KDL-46S2510/S2530 UK/AEP)		15	2-663-978-22	COVER, BUTTON	
4	1-826-363-11	LOUDSPEAKER (4.2X15CM)	(32S2510/S2520/S2530UK/AEP)	16	*2-672-470-21	SHIELD, (A, TUNER)	
	1-826-362-11	LOUDSPEAKER (5.5X15.5CM) (40S2510/S2530 UK/AEP)		17	*2-672-348-12	BRACKET, G1 (32S2510/S2520/S2530 UK/AEP)	
	1-826-435-11	LOUDSPEAKER (13X7CM) (46S2510/S2530 UK/AEP)			*2-664-617-11	BRACKET, G2 (40/46S2510/S2530 UK/AEP)	
5	1-802-261-11	LCD PANEL (32S2510/S2520/S2530 UK/AEP)		18	*A-1172-590-D	H1E BOARD COMPLETE	
	1-802-267-11	LCD PANEL (40S2510/S2530 UK/AEP)		19	*A-1172-592-D	H3E BOARD COMPLETE	
	1-802-133-41	LCD PANEL (46S2510/S2530 UK/AEP)					

Note : The components identified by mark  contain confidential information. Strictly follow the instructions when ever the components are repaired and/or replaced.

5-1. CHASSIS Cont.

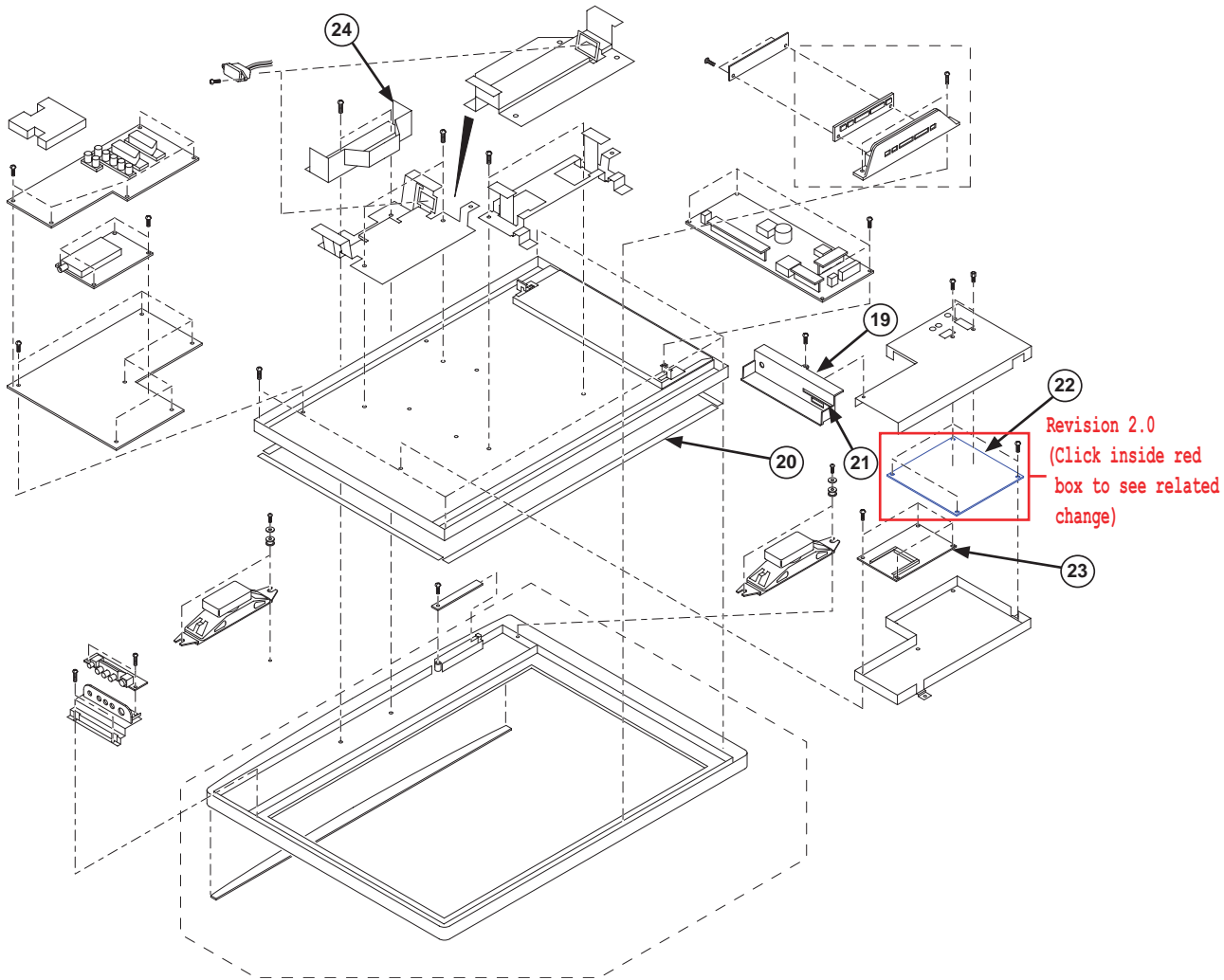

REF.NO.	PART.NO	DESCRIPTION	REMARK	REF.NO.	PART.NO	DESCRIPTION	REMARK
19	*2-696-147-01	SIDE, TERMINAL BKT (C)					
20	4-660-752-01	TAPE (LCD) (32S2510/S2520/S2530 UK/AEP)					
21	2-667-975-01	COVER, PCMCIA					
22	 *A-1214-950-A	B2H BOARD COMPLETE	Revision 2.0 (Click inside red box to see related change)				
23	*A-1173-179-K	FEE BOARD COMPLETE					
24	2-660-802-11	COVER, UNDER (M) (32S2510/S2520/S2530 UK/AEP)					
	2-660-801-12	COVER, UNDER (L) (40/46S2510/S2530 UK/AEP)					

5-2. REAR COVER, STAND and VESA BRACKET

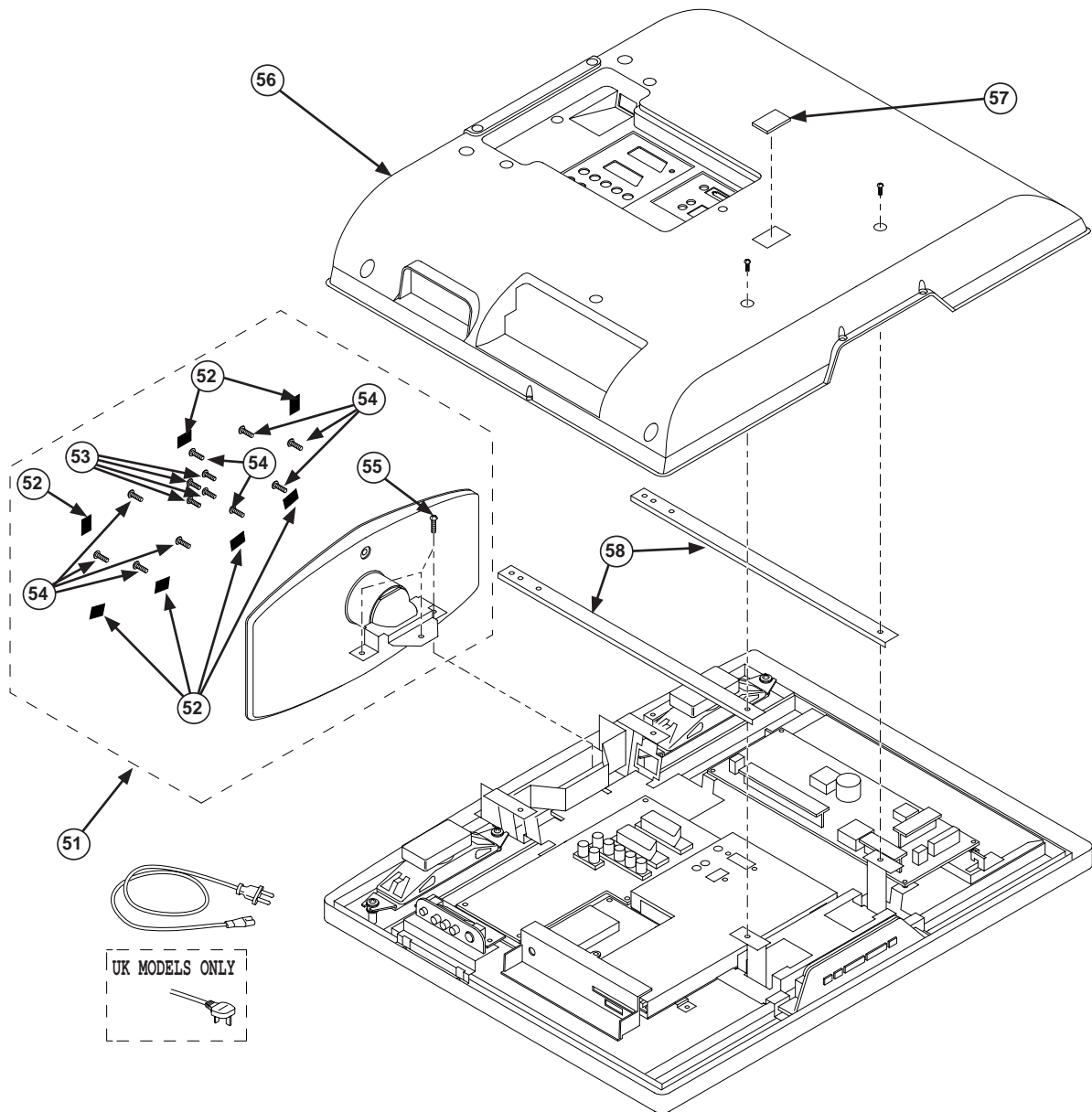

REF.NO.	PART.NO	DESCRIPTION	REMARK	REF.NO.	PART.NO	DESCRIPTION	REMARK
51	X-2148-360-1	STAND ASSY (M) (32S2510 UK/AEP)	52-55		2-689-628-01	SCREW, (B) 5X30 (40/46S2510/S2530 UK/AEP)	
	X-2109-668-1	STAND ASSY (M) (32S2520 UK/AEP)	52-55	56	2-679-157-31	COVER, REAR (32) (32S2510/S2520/S2530 UK/AEP)	
	X-2149-692-1	STAND ASSY (M) (32S2530 UK/AEP)	52-55		2-672-439-51	COVER, REAR (40) (40S2510/S2530 UK/AEP)	
	X-2149-790-1	STAND ASSY (ML)S (40S2510 UK/AEP)	52-55		2-679-182-61	COVER, REAR (46) (46S2510/S2530 UK/AEP)	
	X-2149-932-1	STAND ASSY (ML) (40S2530 UK/AEP)	52-55	57	2-664-636-11	COVER, ECS	
	X-2109-667-3	STAND ASSY (L) (46S2510 UK/AEP)	52-55	58	X-2109-236-2	BRACKET,VESA (32) ASSY (32S2510/S2520/S2530 UK/AEP)	
	X-2148-378-2	STAND ASSY (L)B (46S2530 UK/AEP)	52-55		X-2109-058-3	VESA BRACKET (40) L ASSY (40S2510/S2530 UK/AEP)	
52	2-675-191-02	FOOT			X-2109-059-3	VESA BRACKET (40) R ASSY (40S2510/S2530 UK/AEP)	
53	2-580-602-01	SCREW, +PSW M4X12			X-2109-250-5	ARM, VESA (46) L ASSY (46S2510/S2530 UK/AEP)	
	2-580-608-01	SCREW, +PSW M5X16			X-2109-251-5	ARM, VESA (46) R ASSY (46S2510/S2530 UK/AEP)	
54	2-580-644-01	SCREW, +KTP2 3X8 (32S2510/S2520/S2530 UK/AEP)					
	2-580-647-01	SCREW, +KTP2 4X12 (40/46S2510/S2530 UK/AEP)					
55	2-689-629-01	SCREW, (B) 4X25 (32S2510/S2520/S2530 UK/AEP)					

Note : Les composants identifiés par une trame et par une marque Δ sont d'une importance critique pour la sécurité. Ne les remplacer que par des pièces du numéro spécifié.

Note : The components identified by shading and marked Δ are critical for safety. Replace only with the part numbers specified in the parts list.

5-2. REAR COVER, STAND and VESA BRACKET Cont.

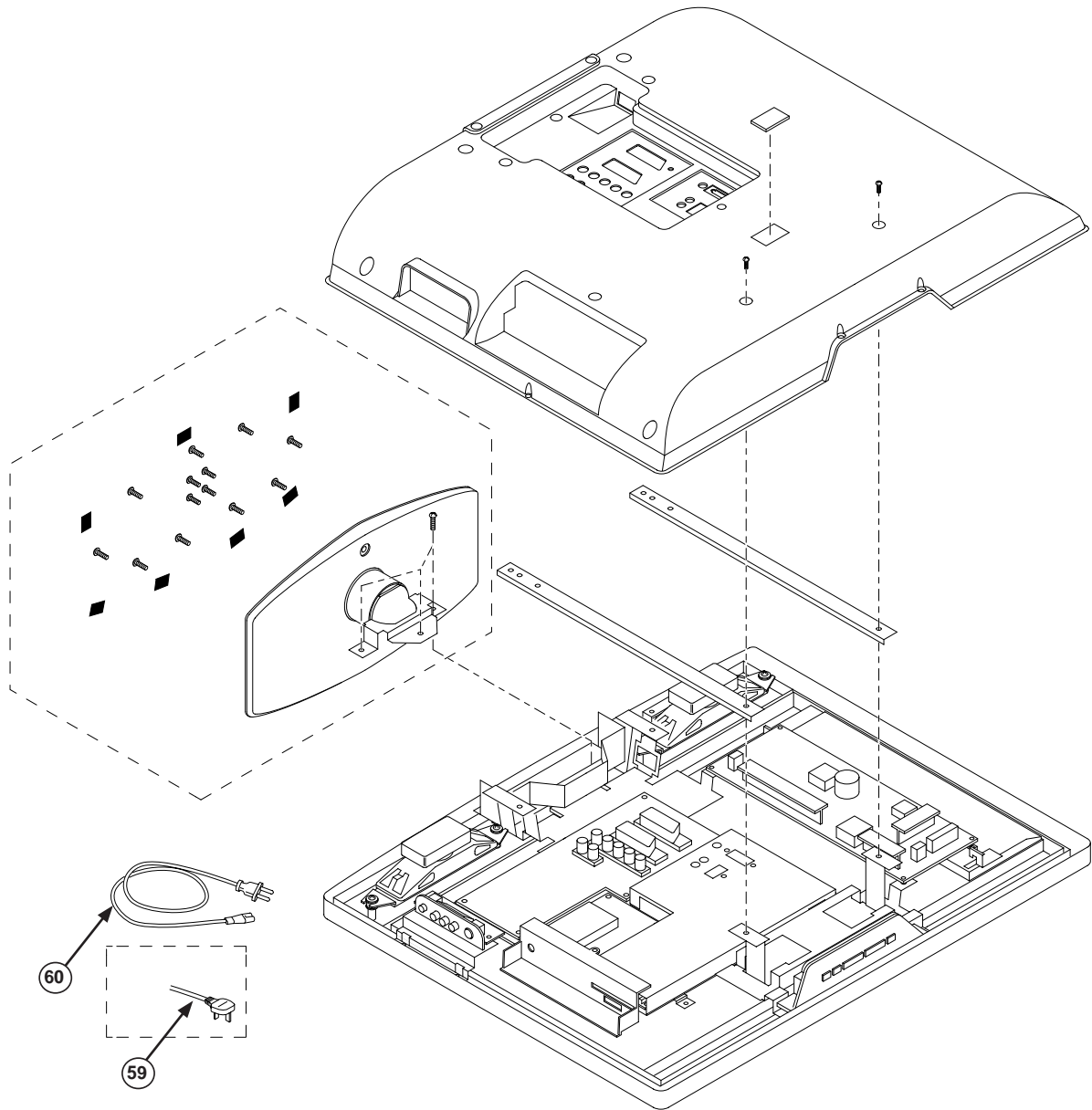

REF.NO.	PART.NO	DESCRIPTION	REMARK	REF.NO.	PART.NO	DESCRIPTION	REMARK
59	Δ 1-832-210-11	POWER-SUPPLY CORD SET (32S2510/S2520/S2530 & 40/46S2510/S2530 UK)					
60	Δ 1-832-211-11	POWER-SUPPLY CORD SET (32S2510/S2520/S2530 & 40/46S2510/S2530 AEP)					

SECTION 6 ELECTRICAL PARTS LIST

PARTS LISTING TABLE OF CONTENTS

	<u>Page</u>
FEE BOARD COMPLETE Parts List :	74
TUE BOARD COMPLETE Parts List :	77
H46E BOARD COMPLETE Parts List :	79
G2A BOARD COMPLETE Parts List :	80
B2H BOARD COMPLETE Parts List :	83
AE BOARD COMPLETE Parts List :	92
H1E BOARD COMPLETE Parts List :	99
H3E BOARD COMPLETE Parts List :	99
H2E BOARD COMPLETE Parts List :	100
MISCELLANEOUS :	101
ACCESSORIES AND CONNECTORS :	101
REMOTE COMMANDER :	101

Note : The G1 board (32 inch only) schematic diagram, printed wiring board and parts list are not indicated in this manual as the PWB is regarded as a non service item for exchange only.

Note : Items marked “*” are not stocked since they are seldom required for routine service. Some delay should be anticipated when ordering these items.
Parts indicated (XX) on the Schematic Diagram are not used in this model and therefore do not appear in the Parts List.

REF.NO.	PART.NO	DESCRIPTION	REMARK	REF.NO.	PART.NO	DESCRIPTION	REMARK
*A-1173-179-K FEE Board, Complete							
< CAPACITOR >							
C3100	1-100-911-11	CERAMIC CHIP 4.7UF	10% 25V	C3208	1-100-907-11	CERAMIC CHIP 0.1UF	10% 10V
C3101	1-117-720-11	CERAMIC CHIP 4.7UF	10V	C3209	1-100-907-11	CERAMIC CHIP 0.1UF	10% 10V
C3102	1-100-907-11	CERAMIC CHIP 0.1UF	10% 10V	C3210	1-100-907-11	CERAMIC CHIP 0.1UF	10% 10V
C3103	1-100-907-11	CERAMIC CHIP 0.1UF	10% 10V	C3211	1-117-720-11	CERAMIC CHIP 4.7UF	10V
C3104	1-100-907-11	CERAMIC CHIP 0.1UF	10% 10V	C3212	1-117-681-11	ELECT CHIP 100UF	20.00% 16V
C3105	1-100-907-11	CERAMIC CHIP 0.1UF	10% 10V	C3214	1-100-907-11	CERAMIC CHIP 0.1UF	10% 10V
C3106	1-100-907-11	CERAMIC CHIP 0.1UF	10% 10V	C3215	1-164-937-11	CERAMIC CHIP 0.001UF	10.00% 50V
C3107	1-100-907-11	CERAMIC CHIP 0.1UF	10% 10V	C3216	1-100-907-11	CERAMIC CHIP 0.1UF	10% 10V
C3108	1-100-907-11	CERAMIC CHIP 0.1UF	10% 10V	C3217	1-117-720-11	CERAMIC CHIP 4.7UF	10V
C3109	1-100-907-11	CERAMIC CHIP 0.1UF	10% 10V	C3218	1-100-907-11	CERAMIC CHIP 0.1UF	10% 10V
C3110	1-100-907-11	CERAMIC CHIP 0.1UF	10% 10V	C3219	1-100-907-11	CERAMIC CHIP 0.1UF	10% 10V
C3111	1-100-907-11	CERAMIC CHIP 0.1UF	10% 10V	C3220	1-100-907-11	CERAMIC CHIP 0.1UF	10% 10V
C3112	1-100-907-11	CERAMIC CHIP 0.1UF	10% 10V	C3300	1-117-720-11	CERAMIC CHIP 4.7UF	10V
C3113	1-100-907-11	CERAMIC CHIP 0.1UF	10% 10V	C3301	1-100-907-11	CERAMIC CHIP 0.1UF	10% 10V
C3114	1-100-907-11	CERAMIC CHIP 0.1UF	10% 10V	C3302	1-117-720-11	CERAMIC CHIP 4.7UF	10V
C3116	1-124-779-00	ELECT CHIP 10UF	20.00% 16V	C3303	1-100-907-11	CERAMIC CHIP 0.1UF	10% 10V
C3120	1-100-907-11	CERAMIC CHIP 0.1UF	10% 10V	C3306	1-100-907-11	CERAMIC CHIP 0.1UF	10% 10V
C3121	1-100-907-11	CERAMIC CHIP 0.1UF	10% 10V	C3307	1-117-720-11	CERAMIC CHIP 4.7UF	10V
C3122	1-100-907-11	CERAMIC CHIP 0.1UF	10% 10V	C3308	1-100-907-11	CERAMIC CHIP 0.1UF	10% 10V
C3123	1-100-907-11	CERAMIC CHIP 0.1UF	10% 10V	C3309	1-100-907-11	CERAMIC CHIP 0.1UF	10% 10V
C3124	1-100-907-11	CERAMIC CHIP 0.1UF	10% 10V	C3310	1-100-907-11	CERAMIC CHIP 0.1UF	10% 10V
C3125	1-100-907-11	CERAMIC CHIP 0.1UF	10% 10V	C3312	1-100-907-11	CERAMIC CHIP 0.1UF	10% 10V
C3126	1-100-907-11	CERAMIC CHIP 0.1UF	10% 10V	C3315	1-100-907-11	CERAMIC CHIP 0.1UF	10% 10V
C3130	1-164-850-11	CERAMIC CHIP 10PF	0.50PF 50V	C3316	1-100-907-11	CERAMIC CHIP 0.1UF	10% 10V
C3131	1-164-850-11	CERAMIC CHIP 10PF	0.50PF 50V	C3320	1-117-720-11	CERAMIC CHIP 4.7UF	10V
C3132	1-164-850-11	CERAMIC CHIP 10PF	0.50PF 50V	C3322	1-164-937-11	CERAMIC CHIP 0.001UF	10.00% 50V
C3133	1-100-911-11	CERAMIC CHIP 4.7UF	10% 25V	C3323	1-100-907-11	CERAMIC CHIP 0.1UF	10% 10V
C3134	1-100-907-11	CERAMIC CHIP 0.1UF	10% 10V	C3324	1-100-907-11	CERAMIC CHIP 0.1UF	10% 10V
C3135	1-100-907-11	CERAMIC CHIP 0.1UF	10% 10V	C3326	1-100-907-11	CERAMIC CHIP 0.1UF	10% 10V
C3136	1-100-911-11	CERAMIC CHIP 4.7UF	10% 25V	C3328	1-100-907-11	CERAMIC CHIP 0.1UF	10% 10V
C3137	1-100-907-11	CERAMIC CHIP 0.1UF	10% 10V	C3402	1-100-907-11	CERAMIC CHIP 0.1UF	10% 10V
C3138	1-100-907-11	CERAMIC CHIP 0.1UF	10% 10V	C3403	1-100-907-11	CERAMIC CHIP 0.1UF	10% 10V
C3139	1-100-907-11	CERAMIC CHIP 0.1UF	10% 10V	C3404	1-164-943-81	CERAMIC CHIP 0.01UF	10.00% 16V
C3140	1-124-779-00	ELECT CHIP 10UF	20.00% 16V	C3405	1-100-907-11	CERAMIC CHIP 0.1UF	10% 10V
C3141	1-100-907-11	CERAMIC CHIP 0.1UF	10% 10V	C3409	1-107-823-11	CERAMIC CHIP 0.47UF	10.00% 16V
C3142	1-100-907-11	CERAMIC CHIP 0.1UF	10% 10V	C3410	1-100-907-11	CERAMIC CHIP 0.1UF	10% 10V
C3143	1-100-907-11	CERAMIC CHIP 0.1UF	10% 10V	C3411	1-164-850-11	CERAMIC CHIP 10PF	0.50PF 50V
C3144	1-100-907-11	CERAMIC CHIP 0.1UF	10% 10V	C3412	1-165-908-11	CERAMIC CHIP 1UF	10% 10V
C3145	1-100-907-11	CERAMIC CHIP 0.1UF	10% 10V	C3413	1-117-720-11	CERAMIC CHIP 4.7UF	10V
C3200	1-100-907-11	CERAMIC CHIP 0.1UF	10% 10V	C3415	1-100-907-11	CERAMIC CHIP 0.1UF	10% 10V
C3201	1-117-720-11	CERAMIC CHIP 4.7UF	10V	C3417	1-100-907-11	CERAMIC CHIP 0.1UF	10% 10V
C3202	1-100-907-11	CERAMIC CHIP 0.1UF	10% 10V	C3428	1-112-066-11	CERAMIC CHIP 10UF	10% 10V
C3203	1-100-907-11	CERAMIC CHIP 0.1UF	10% 10V	C3432	1-100-907-11	CERAMIC CHIP 0.1UF	10% 10V
C3205	1-100-907-11	CERAMIC CHIP 0.1UF	10% 10V	C3436	1-117-681-11	ELECT CHIP 100UF	20.00% 16V
C3206	1-165-908-11	CERAMIC CHIP 1UF	10% 10V	C3439	1-165-681-21	ELECT CHIP 180UF	20% 16V
C3207	1-100-907-11	CERAMIC CHIP 0.1UF	10% 10V	C3442	1-164-882-11	CERAMIC CHIP 220PF	5.00% 16V
				C3443	1-107-819-11	CERAMIC CHIP 0.022UF	10.00% 16V
				C3444	1-135-960-91	CERAMIC CHIP 10UF	10% 25V
				C3445	1-165-671-21	ELECT CHIP 470UF	20% 6.3V
				C3446	1-100-907-11	CERAMIC CHIP 0.1UF	10% 10V

REF.NO.	PART.NO	DESCRIPTION	REMARK	REF.NO.	PART.NO	DESCRIPTION	REMARK
C3502	1-164-937-11	CERAMIC CHIP 0.001UF	10.00% 50V	FB3300	1-469-869-21	FERRITE	OUH
C3503	1-100-907-11	CERAMIC CHIP 0.1UF	10% 10V	FB3301	1-469-869-21	FERRITE	OUH
C3505	1-100-907-11	CERAMIC CHIP 0.1UF	10% 10V	FB3402	1-400-244-11	FERRITE	OUH
C3506	1-107-823-11	CERAMIC CHIP 0.47UF	10.00% 16V	FB3403	1-400-834-11	FERRITE	OUH
C3605	1-117-681-11	ELECT CHIP 100UF	20.00% 16V	FB3407	1-469-869-21	FERRITE	OUH
C3606	1-117-681-11	ELECT CHIP 100UF	20.00% 16V	FB3408	1-400-461-21	FERRITE	OUH
C3607	1-117-681-11	ELECT CHIP 100UF	20.00% 16V	FB3409	1-400-461-21	FERRITE	OUH
C3609	1-100-597-91	CERAMIC CHIP 0.1UF	10% 25V	FB3410	1-400-461-21	FERRITE	OUH
C3610	1-100-907-11	CERAMIC CHIP 0.1UF	10% 10V	FB3411	1-400-461-21	FERRITE	OUH
C3611	1-100-907-11	CERAMIC CHIP 0.1UF	10% 10V	FB3412	1-400-834-11	FERRITE	OUH
< CONNECTOR >				FB3413	1-400-834-11	FERRITE	OUH
CN3300	*1-793-769-21	CONNECTOR, CARD (PCMCIA CARD)		FB3414	1-400-834-11	FERRITE	OUH
CN3401	*1-819-475-11	HEADER ASSEMBLY FOR PWB 7P		FB3415	1-400-834-11	FERRITE	OUH
CN3600	*1-820-235-21	HEADER ASSEMBLY 30P		FB3416	1-400-834-11	FERRITE	OUH
CN3601	1-820-209-11	MEMORY STICK CONNECTOR		FB3417	1-400-834-11	FERRITE	OUH
CN3610	1-780-336-11	EARTH TERMINAL		FB3418	1-400-834-11	FERRITE	OUH
CN3611	1-780-336-11	EARTH TERMINAL		FB3419	1-400-834-11	FERRITE	OUH
< DIODE >				FB3601	1-469-869-21	FERRITE	OUH
D3400	6-501-060-01	DIODE STPS2L25U		FB3602	1-469-869-21	FERRITE	OUH
D3401	6-500-294-01	DIODE PTZ-TE25-3.9B		FB3603	1-469-869-21	FERRITE	OUH
D3503	8-719-066-11	DIODE 1PS184-115		FB3604	1-400-834-11	FERRITE	OUH
< FERRITE BEAD >				FB3605	1-400-834-11	FERRITE	OUH
FB3103	1-400-834-11	FERRITE	OUH	FB3606	1-400-834-11	FERRITE	OUH
FB3104	1-400-834-11	FERRITE	OUH	FB3607	1-400-834-11	FERRITE	OUH
FB3105	1-400-834-11	FERRITE	OUH	FB3608	1-400-834-11	FERRITE	OUH
FB3106	1-400-834-11	FERRITE	OUH	FB3609	1-400-834-11	FERRITE	OUH
FB3107	1-400-834-11	FERRITE	OUH	FB3610	1-400-834-11	FERRITE	OUH
FB3108	1-400-834-11	FERRITE	OUH	FB3611	1-400-834-11	FERRITE	OUH
FB3109	1-400-834-11	FERRITE	OUH	FB3612	1-400-834-11	FERRITE	OUH
FB3110	1-400-834-11	FERRITE	OUH	FB3613	1-400-834-11	FERRITE	OUH
FB3111	1-400-834-11	FERRITE	OUH	FB3614	1-400-834-11	FERRITE	OUH
FB3113	1-400-834-11	FERRITE	OUH	FB3615	1-400-834-11	FERRITE	OUH
FB3114	1-469-869-21	FERRITE	OUH	FB3616	1-400-834-11	FERRITE	OUH
FB3115	1-400-244-11	FERRITE	OUH	FB3617	1-400-834-11	FERRITE	OUH
FB3116	1-400-244-11	FERRITE	OUH	FB3618	1-400-834-11	FERRITE	OUH
FB3117	1-469-869-21	FERRITE	OUH	FB3619	1-400-834-11	FERRITE	OUH
FB3118	1-469-869-21	FERRITE	OUH	FB3620	1-400-834-11	FERRITE	OUH
FB3119	1-400-807-21	FERRITE	OUH	< IC >			
FB3120	1-400-807-21	FERRITE	OUH	IC3100	6-709-214-01	IC UPD61123F1-100-KA3-A	
FB3121	1-400-807-21	FERRITE	OUH	IC3200	6-707-809-01	IC EDD1216AATA-6B-E	
FB3122	1-400-807-21	FERRITE	OUH	IC3201	6-708-916-01	IC ICS7150MLFT	
FB3123	1-400-807-21	FERRITE	OUH	IC3206	6-705-336-01	IC K9F2808U0C-PCB0T	
FB3125	1-469-869-21	FERRITE	OUH	IC3301	6-707-853-01	IC TC74LCX541FT (EKJ)	
FB3126	1-400-244-11	FERRITE	OUH	IC3302	6-707-853-01	IC TC74LCX541FT (EKJ)	
FB3127	1-400-244-11	FERRITE	OUH	IC3304	6-707-853-01	IC TC74LCX541FT (EKJ)	
FB3200	1-400-244-11	FERRITE	OUH	IC3305	6-707-853-01	IC TC74LCX541FT (EKJ)	
FB3201	1-400-244-11	FERRITE	OUH	IC3306	6-707-853-01	IC TC74LCX541FT (EKJ)	
				IC3308	6-707-853-01	IC TC74LCX541FT (EKJ)	

REF.NO.	PART.NO	DESCRIPTION	REMARK	REF.NO.	PART.NO	DESCRIPTION	REMARK
IC3311	6-707-850-01	IC TC74LCX245FT(EKJ)		R3142	1-218-937-11	RES-CHIP	47 5% 1/16W
IC3312	6-707-853-01	IC TC74LCX541FT(EKJ)		R3143	1-218-937-11	RES-CHIP	47 5% 1/16W
IC3316	6-708-132-01	IC 74LVC14APW		R3144	1-218-937-11	RES-CHIP	47 5% 1/16W
IC3317	6-706-482-01	IC TC7SH00FU(T5RSOYJF)		R3146	1-218-965-11	RES-CHIP	10K 5% 1/16W
IC3402	6-705-790-01	IC LM3525MX-H/J5000395		R3147	1-218-965-11	RES-CHIP	10K 5% 1/16W
IC3404	6-706-106-01	IC NCP1117STAT3		R3148	1-218-965-11	RES-CHIP	10K 5% 1/16W
IC3405	6-708-603-01	IC PQ070XNA1ZPH		R3149	1-218-990-81	SHORT CHIP	0
IC3406	6-707-078-01	IC L5973ADTR		R3150	1-218-965-11	RES-CHIP	10K 5% 1/16W
IC3501	6-703-175-01	IC PST3629UL		R3151	1-218-965-11	RES-CHIP	10K 5% 1/16W
		< COIL >		R3200	1-218-941-11	RES-CHIP	100 5% 1/16W
L3100	1-414-398-11	INDUCTOR	10UH	R3201	1-218-941-11	RES-CHIP	100 5% 1/16W
L3400	1-419-353-21	INDUCTOR	10UH	R3202	1-218-939-11	RES-CHIP	68 5% 1/16W
L3401	*1-424-924-21	COIL, POWER		R3203	1-218-941-81	RES-CHIP	100 5% 1/16W
		< TRANSISTOR >		R3204	1-218-941-81	RES-CHIP	100 5% 1/16W
Q3409	8-729-010-05	TRANSISTOR MSB709-RT1		R3205	1-218-937-11	RES-CHIP	47 5% 1/16W
Q3501	8-729-027-43	TRANSISTOR DTC114EKA-T146		R3207	1-218-953-11	RES-CHIP	1K 5% 1/16W
Q3502	8-729-027-43	TRANSISTOR DTC114EKA-T146		R3209	1-218-953-11	RES-CHIP	1K 5% 1/16W
		< RESISTOR >		R3210	1-218-953-11	RES-CHIP	1K 5% 1/16W
R3100	1-218-965-11	RES-CHIP	10K 5% 1/16W	R3212	1-218-953-11	RES-CHIP	1K 5% 1/16W
R3101	1-218-941-81	RES-CHIP	100 5% 1/16W	R3214	1-218-953-11	RES-CHIP	1K 5% 1/16W
R3102	1-218-941-81	RES-CHIP	100 5% 1/16W	R3217	1-218-953-11	RES-CHIP	1K 5% 1/16W
R3103	1-218-941-81	RES-CHIP	100 5% 1/16W	R3218	1-218-953-11	RES-CHIP	1K 5% 1/16W
R3104	1-218-941-81	RES-CHIP	100 5% 1/16W	R3220	1-218-953-11	RES-CHIP	1K 5% 1/16W
R3105	1-218-961-11	RES-CHIP	4.7K 5% 1/16W	R3222	1-218-953-11	RES-CHIP	1K 5% 1/16W
R3106	1-218-961-11	RES-CHIP	4.7K 5% 1/16W	R3224	1-218-953-11	RES-CHIP	1K 5% 1/16W
R3109	1-218-941-81	RES-CHIP	100 5% 1/16W	R3226	1-218-953-11	RES-CHIP	1K 5% 1/16W
R3110	1-218-941-81	RES-CHIP	100 5% 1/16W	R3229	1-218-953-11	RES-CHIP	1K 5% 1/16W
R3111	1-218-941-81	RES-CHIP	100 5% 1/16W	R3230	1-218-953-11	RES-CHIP	1K 5% 1/16W
R3112	1-218-941-81	RES-CHIP	100 5% 1/16W	R3233	1-218-953-11	RES-CHIP	1K 5% 1/16W
R3113	1-218-965-11	RES-CHIP	10K 5% 1/16W	R3235	1-218-953-11	RES-CHIP	1K 5% 1/16W
R3114	1-218-965-11	RES-CHIP	10K 5% 1/16W	R3237	1-218-961-11	RES-CHIP	4.7K 5% 1/16W
R3115	1-218-965-11	RES-CHIP	10K 5% 1/16W	R3238	1-218-953-11	RES-CHIP	1K 5% 1/16W
R3117	1-218-965-11	RES-CHIP	10K 5% 1/16W	R3239	1-218-965-11	RES-CHIP	10K 5% 1/16W
R3119	1-218-990-81	SHORT CHIP	0	R3240	1-218-939-11	RES-CHIP	68 5% 1/16W
R3120	1-218-990-81	SHORT CHIP	0	R3241	1-218-953-11	RES-CHIP	1K 5% 1/16W
R3125	1-218-937-11	RES-CHIP	47 5% 1/16W	R3242	1-218-941-81	RES-CHIP	100 5% 1/16W
R3126	1-218-990-81	SHORT CHIP	0	R3244	1-218-953-11	RES-CHIP	1K 5% 1/16W
R3127	1-220-174-11	RES-CHIP	200 5% 1/16W	R3247	1-218-953-11	RES-CHIP	1K 5% 1/16W
R3128	1-220-174-11	RES-CHIP	200 5% 1/16W	R3249	1-218-953-11	RES-CHIP	1K 5% 1/16W
R3129	1-220-174-11	RES-CHIP	200 5% 1/16W	R3250	1-218-953-11	RES-CHIP	1K 5% 1/16W
R3130	1-220-174-11	RES-CHIP	200 5% 1/16W	R3251	1-218-949-11	RES-CHIP	470 5% 1/16W
R3131	1-220-174-11	RES-CHIP	200 5% 1/16W	R3254	1-218-953-11	RES-CHIP	1K 5% 1/16W
R3132	1-220-174-11	RES-CHIP	200 5% 1/16W	R3255	1-218-953-11	RES-CHIP	1K 5% 1/16W
R3133	1-208-671-11	METAL CHIP	330 0.5% 1/16W	R3258	1-218-941-81	RES-CHIP	100 5% 1/16W
R3134	1-208-679-11	METAL CHIP	680 0.5% 1/16W	R3259	1-218-953-11	RES-CHIP	1K 5% 1/16W
R3136	1-208-675-11	METAL CHIP	470 0.5% 1/16W	R3263	1-218-965-11	RES-CHIP	10K 5% 1/16W
R3138	1-218-990-81	SHORT CHIP	0	R3264	1-218-949-11	RES-CHIP	470 5% 1/16W
				R3265	1-218-949-11	RES-CHIP	470 5% 1/16W
				R3300	1-218-965-11	RES-CHIP	10K 5% 1/16W
				R3301	1-218-965-11	RES-CHIP	10K 5% 1/16W

REF.NO.	PART.NO	DESCRIPTION	REMARK	REF.NO.	PART.NO	DESCRIPTION	REMARK
C3909	1-128-991-21	ELECT CHIP 10UF	20% 50V			< FILTER >	
C3910	1-126-204-11	ELECT CHIP 47UF	20.00% 16V				
C3911	1-100-907-11	CERAMIC CHIP 0.1UF	10% 10V	FL3800	1-239-899-21	FERRITE	0UH
C3914	1-164-947-11	CERAMIC CHIP 0.01UF	50V			< IC >	
C3917	1-117-681-11	ELECT CHIP 100UF	20.00% 16V				
C3918	1-135-595-11	ELECT 100UF	20% 6.3V	IC3802	6-706-106-01	IC NCP1117STAT3	
C3919	1-135-595-11	ELECT 100UF	20% 6.3V	IC3900	6-709-257-01	IC 74LVC4066PW	
C3920	1-100-566-91	CERAMIC CHIP 0.1UF	10.00% 25V			< COIL >	
C3921	1-100-907-11	CERAMIC CHIP 0.1UF	10% 10V				
C3923	1-164-943-81	CERAMIC CHIP 0.01UF	10.00% 16V				
C3924	1-100-907-11	CERAMIC CHIP 0.1UF	10% 10V	L3804	1-400-175-21	INDUCTOR	47UH
C3926	1-100-907-11	CERAMIC CHIP 0.1UF	10% 10V	L3805	1-410-993-42	INDUCTOR	1UH
C3927	1-100-907-11	CERAMIC CHIP 0.1UF	10% 10V	L3900	1-412-006-31	INDUCTOR	10UH
C3929	1-100-907-11	CERAMIC CHIP 0.1UF	10% 10V	L3902	*1-424-924-21	COIL, POWER	
C3930	1-100-907-11	CERAMIC CHIP 0.1UF	10% 10V	L3903	1-410-993-42	INDUCTOR	1UH
C3931	1-100-907-11	CERAMIC CHIP 0.1UF	10% 10V	L3904	1-412-989-11	INDUCTOR	6.8UH
C3932	1-115-566-11	CERAMIC CHIP 4.7UF	10.00% 10V			< TRANSISTOR >	
C3933	1-100-907-11	CERAMIC CHIP 0.1UF	10% 10V	Q3900	8-729-027-43	TRANSISTOR DTC114EKA-T146	
C3935	1-117-681-11	ELECT CHIP 100UF	20.00% 16V	Q3901	6-550-237-01	TRANSISTOR 2SC5658T2LQ/R	
C3937	1-100-907-11	CERAMIC CHIP 0.1UF	10% 10V	Q3902	6-550-237-01	TRANSISTOR 2SC5658T2LQ/R	
C3941	1-164-852-11	CERAMIC CHIP 12PF	5.00% 50V	Q3903	6-550-871-01	TRANSISTOR 2SA2048TL QR	
C3942	1-164-852-11	CERAMIC CHIP 12PF	5.00% 50V	Q3904	6-550-871-01	TRANSISTOR 2SA2048TL QR	
C3945	1-115-566-11	CERAMIC CHIP 4.7UF	10.00% 10V	Q3905	6-550-871-01	TRANSISTOR 2SA2048TL QR	
C3946	1-115-566-11	CERAMIC CHIP 4.7UF	10.00% 10V	Q3906	6-550-237-01	TRANSISTOR 2SC5658T2LQ/R	
C3947	1-164-852-11	CERAMIC CHIP 12PF	5.00% 50V	Q3907	6-550-232-01	TRANSISTOR 2SA2029T2LQ/R	
C3948	1-164-852-11	CERAMIC CHIP 12PF	5.00% 50V			< RESISTOR >	
C3950	1-100-611-91	CERAMIC CHIP 22UF	20% 6.3V	R3810	1-208-683-11	METAL CHIP 1K 0.5%	1/16W
C3951	1-128-405-11	ELECT CHIP 22UF	20% 50V	R3812	1-218-948-11	RES-CHIP 390 5%	1/16W
C3952	1-100-907-11	CERAMIC CHIP 0.1UF	10% 10V	R3813	1-218-937-11	RES-CHIP 47 5%	1/16W
C3953	1-100-053-21	ELECT CHIP 220UF	20% 6.3V	R3900	1-216-295-91	SHORT CHIP 0	
C3954	1-164-866-11	CERAMIC CHIP 47PF	5.00% 50V	R3901	1-218-990-81	SHORT CHIP 0	
C3955	1-164-936-11	CERAMIC CHIP 680PF	10.00% 50V	R3902	1-218-938-11	RES-CHIP 56 5%	1/16W
C3956	1-164-936-11	CERAMIC CHIP 680PF	10.00% 50V	R3903	1-218-953-11	RES-CHIP 1K 5%	1/16W
		< CONNECTOR >		R3904	1-218-937-11	RES-CHIP 47 5%	1/16W
CN3802	1-819-339-11	HEADER ASSEMBLY FOR PWB 12P		R3906	1-216-821-11	METAL CHIP 1K 5%	1/10W
CN3900	1-695-915-11	TAB (CONTACT)		R3907	1-218-973-11	RES-CHIP 47K 5%	1/16W
CN3901	*1-820-235-21	HEADER ASSEMBLY 30P		R3908	1-218-937-11	RES-CHIP 47 5%	1/16W
CN3903	1-819-337-11	HEADER ASSEMBLY FOR PWB 10P		R3909	1-218-965-11	RES-CHIP 10K 5%	1/16W
CN3904	*1-819-474-11	HEADER ASSEMBLY FOR PWB 6P		R3911	1-218-990-81	SHORT CHIP 0	
CN3907	1-780-336-11	EARTH TERMINAL		R3913	1-218-965-11	RES-CHIP 10K 5%	1/16W
		< DIODE >		R3918	1-218-941-81	RES-CHIP 100 5%	1/16W
D3900	8-719-083-87	DIODE UDZS-TE17-33B		R3919	1-218-941-81	RES-CHIP 100 5%	1/16W
		< FERRITE BEAD >		R3921	1-218-941-81	RES-CHIP 100 5%	1/16W
FB3901	1-469-869-21	FERRITE 0UH		R3922	1-218-941-81	RES-CHIP 100 5%	1/16W
FB3902	1-469-869-21	FERRITE 0UH		R3924	1-218-933-11	RES-CHIP 22 5%	1/16W
FB3903	1-469-869-21	FERRITE 0UH		R3925	1-218-933-11	RES-CHIP 22 5%	1/16W
FB3909	1-469-869-21	FERRITE 0UH		R3926	1-218-941-81	RES-CHIP 100 5%	1/16W
				R3927	1-218-965-11	RES-CHIP 10K 5%	1/16W
				R3929	1-218-990-81	SHORT CHIP 0	

REF.NO.	PART.NO	DESCRIPTION	REMARK	REF.NO.	PART.NO	DESCRIPTION	REMARK
R3930	1-218-990-81	SHORT CHIP	0	C205	1-125-891-11	CERAMIC CHIP 0.47UF	10.00% 10V
R3938	1-218-941-81	RES-CHIP	100 5% 1/16W	C206	1-125-889-91	CERAMIC CHIP 2.2UF	10% 10V
R3943	1-218-949-11	RES-CHIP	470 5% 1/16W	C207	1-125-889-91	CERAMIC CHIP 2.2UF	10% 10V
R3945	1-218-953-11	RES-CHIP	1K 5% 1/16W	C208	1-125-889-91	CERAMIC CHIP 2.2UF	10% 10V
R3946	1-218-949-11	RES-CHIP	470 5% 1/16W	C209	1-162-927-11	CERAMIC CHIP 100PF	5.00% 50V
R3947	1-218-929-11	RES-CHIP	10 5% 1/16W	C210	1-164-227-11	CERAMIC CHIP 0.022UF	10.00% 25V
R3948	1-218-929-11	RES-CHIP	10 5% 1/16W	C211	1-162-927-11	CERAMIC CHIP 100PF	5.00% 50V
R3950	1-218-961-11	RES-CHIP	4.7K 5% 1/16W	C212	1-164-227-11	CERAMIC CHIP 0.022UF	10.00% 25V
R3951	1-218-961-11	RES-CHIP	4.7K 5% 1/16W	C215	1-115-416-11	CERAMIC CHIP 0.001UF	5.00% 25V
R3952	1-218-937-11	RES-CHIP	47 5% 1/16W	< CONNECTOR >			
R3953	1-218-941-81	RES-CHIP	100 5% 1/16W	CN201	1-820-192-11	HEADER ASSEMBLY (PRINT PWB)15P	
R3958	1-218-957-11	RES-CHIP	2.2K 5% 1/16W	< DIODE >			
R3959	1-218-953-11	RES-CHIP	1K 5% 1/16W	D201	8-719-070-63	DIODE PDZ10B-115	
R3960	1-218-953-11	RES-CHIP	1K 5% 1/16W	D202	8-719-070-63	DIODE PDZ10B-115	
R3961	1-218-965-11	RES-CHIP	10K 5% 1/16W	D203	8-719-070-63	DIODE PDZ10B-115	
R3962	1-218-969-11	RES-CHIP	22K 5% 1/16W	D204	8-719-070-63	DIODE PDZ10B-115	
R3967	1-218-941-81	RES-CHIP	100 5% 1/16W	D205	8-719-070-63	DIODE PDZ10B-115	
R3970	1-218-953-11	RES-CHIP	1K 5% 1/16W	D206	8-719-070-63	DIODE PDZ10B-115	
R3971	1-218-969-11	RES-CHIP	22K 5% 1/16W	< SOCKET >			
R3973	1-218-990-81	SHORT CHIP	0	J201	1-780-368-11	S TERMINAL BLOCK (RIGHT ANGLE)	
R3974	1-218-990-81	SHORT CHIP	0	J202	1-815-325-11	JACK	
R3980	1-218-941-81	RES-CHIP	100 5% 1/16W	< RESISTOR >			
R3981	1-218-933-11	RES-CHIP	22 5% 1/16W	R201	1-216-864-11	SHORT CHIP	0
R3982	1-218-953-11	RES-CHIP	1K 5% 1/16W	R202	1-216-864-11	SHORT CHIP	0
R3983	1-218-990-81	SHORT CHIP	0	R205	1-216-821-11	METAL CHIP	1K 5% 1/10W
R3984	1-218-990-81	SHORT CHIP	0	R206	1-216-821-11	METAL CHIP	1K 5% 1/10W
R3985	1-218-990-81	SHORT CHIP	0	R207	1-218-831-11	METAL CHIP	220 0.5% 1/10W
R3986	1-218-990-81	SHORT CHIP	0	R208	1-218-831-11	METAL CHIP	220 0.5% 1/10W
R3987	1-218-990-81	SHORT CHIP	0	R209	1-218-285-11	METAL CHIP	75 5% 1/10W
R3988	1-218-990-81	SHORT CHIP	0	R210	1-218-831-11	METAL CHIP	220 0.5% 1/10W
R3989	1-218-990-81	SHORT CHIP	0	R211	1-218-831-11	METAL CHIP	220 0.5% 1/10W
R3996	1-218-990-81	SHORT CHIP	0	R212	1-216-797-11	METAL CHIP	10 5% 1/10W
R3997	1-218-933-11	RES-CHIP	22 5% 1/16W	R213	1-216-821-11	METAL CHIP	1K 5% 1/10W
R3998	1-218-933-11	RES-CHIP	22 5% 1/16W	R214	1-216-821-11	METAL CHIP	1K 5% 1/10W
< RESISTOR CHIP >				R215	1-216-809-11	METAL CHIP	100 5% 1/10W
RB3900	1-234-371-21	RES, NETWORK	47 (1005X4)	R216	1-216-809-11	METAL CHIP	100 5% 1/10W
RB3901	1-234-371-21	RES, NETWORK	47 (1005X4)	R217	1-216-821-11	METAL CHIP	1K 5% 1/10W
RB3902	1-234-371-21	RES, NETWORK	47 (1005X4)	R218	1-216-821-11	METAL CHIP	1K 5% 1/10W
< TUNER >				R219	1-216-809-11	METAL CHIP	100 5% 1/10W
TU3901	8-597-598-00	TUNER UNIT, DIGITAL	BTD-HF441Z	R220	1-216-797-11	METAL CHIP	10 5% 1/10W
*A-1192-084-B H46E Board, Complete (46 inch only)				R222	1-216-853-11	METAL CHIP	470K 5% 1/10W
< CAPACITOR >				R223	1-216-853-11	METAL CHIP	470K 5% 1/10W
C201	1-162-964-11	CERAMIC CHIP	0.001UF 10.00% 50V	R224	1-218-831-11	METAL CHIP	220 0.5% 1/10W
C202	1-162-964-11	CERAMIC CHIP	0.001UF 10.00% 50V	R225	1-218-831-11	METAL CHIP	220 0.5% 1/10W
C203	1-127-573-11	CERAMIC CHIP	1UF 10% 16V	R226	1-216-864-11	SHORT CHIP	0
C204	1-127-573-11	CERAMIC CHIP	1UF 10% 16V				

Note : The components identified by shading and marked Δ are critical for safety. Replace only with the part numbers specified in the parts list.

H46E G2A

REF.NO.	PART.NO	DESCRIPTION	REMARK	REF.NO.	PART.NO	DESCRIPTION	REMARK
< VARISTOR >							
VD201	1-802-082-11	VARISTOR (SMD)		C6316	1-107-826-11	CERAMIC CHIP 0.1UF	10.00% 16V
VD202	1-802-082-11	VARISTOR (SMD)		C6401	1-107-882-91	ELECT 100UF	20% 16V
VD203	1-802-082-11	VARISTOR (SMD)		C6402	1-127-573-11	CERAMIC CHIP 1UF	10% 16V
				C6404	1-107-826-11	CERAMIC CHIP 0.1UF	10.00% 16V
				C6405	1-115-339-11	CERAMIC CHIP 0.1UF	10.00% 50V
*A-1184-357-B G2A Board, Complete (40/46 inch)							
	4-382-854-11	SCREW (M3X10), P, SW (+)		C6406	1-162-964-11	CERAMIC CHIP 0.001UF	10.00% 50V
< CAPACITOR >				C6407	1-162-970-11	CERAMIC CHIP 0.01UF	10.00% 25V
C6000	Δ 1-161-964-91	CERAMIC 0.0047UF	250V	C6408	1-125-891-11	CERAMIC CHIP 0.47UF	10.00% 10V
C6001	Δ 1-119-892-51	CERAMIC 470PF	10.00% 250V	C6409	1-162-964-11	CERAMIC CHIP 0.001UF	10.00% 50V
C6002	Δ 1-165-531-11	MYLAR 1UF	10 275V	C6412	1-125-891-11	CERAMIC CHIP 0.47UF	10.00% 10V
C6003	Δ 1-161-964-91	CERAMIC 0.0047UF	250V	C6413	1-162-964-11	CERAMIC CHIP 0.001UF	10.00% 50V
C6004	Δ 1-165-529-11	MYLAR 0.22UF	10 275V	C6451	1-107-826-11	CERAMIC CHIP 0.1UF	10.00% 16V
C6005	Δ 1-119-892-51	CERAMIC 470PF	10.00% 250V	C6454	1-125-889-91	CERAMIC CHIP 2.2UF	10% 10V
C6006	1-135-361-11	ELECT (BLOCK) 180UF	20% 450V	C6504	1-162-134-11	CERAMIC 470PF	10.00% 2KV
C6008	1-135-361-11	ELECT (BLOCK) 180UF	20% 450V	C6505	1-162-134-11	CERAMIC 470PF	10.00% 2KV
C6010	Δ 1-113-889-11	CERAMIC 0.001UF	20.00% 250V	C6507	1-107-888-11	ELECT 47UF	20% 25V
C6012	Δ 1-113-889-11	CERAMIC 0.001UF	20.00% 250V	C6517	1-117-227-11	MYLAR 1UF	10.00% 450V
C6015	Δ 1-113-889-11	CERAMIC 0.001UF	20.00% 250V	C6518	1-112-744-52	MYLAR 1UF	10% 450V
C6016	Δ 1-113-889-11	CERAMIC 0.001UF	20.00% 250V	C6519	1-162-969-11	CERAMIC CHIP 0.0068UF	10.00% 25V
C6051	1-162-970-11	CERAMIC CHIP 0.01UF	10.00% 25V	C6520	1-117-227-11	MYLAR 1UF	10.00% 450V
C6100	1-162-970-11	CERAMIC CHIP 0.01UF	10.00% 25V	C6521	1-107-823-11	CERAMIC CHIP 0.47UF	10.00% 16V
C6101	1-107-905-11	ELECT 4.7UF	20% 50V	C6522	1-162-964-11	CERAMIC CHIP 0.001UF	10.00% 50V
C6102	1-107-910-11	ELECT 100UF	20% 50V	C6523	1-162-970-11	CERAMIC CHIP 0.01UF	10.00% 25V
C6103	1-107-826-11	CERAMIC CHIP 0.1UF	10.00% 16V	C6525	1-115-339-11	CERAMIC CHIP 0.1UF	10.00% 50V
C6104	1-100-831-91	CERAMIC CHIP 0.001UF	2% 50V	C6526	1-107-906-11	ELECT 10UF	20% 50V
C6105	1-107-906-11	ELECT 10UF	20% 50V	< CONNECTOR >			
C6108	1-115-340-11	CERAMIC CHIP 0.22UF	10.00% 25V	CN6000	1-695-915-11	TAB (CONTACT)	
C6109	1-107-888-11	ELECT 47UF	20% 25V	CN6001	Δ *1-793-660-11	PIN, CONNECTOR (PC BOARD) 3P	
C6111	1-162-134-11	CERAMIC 470PF	10.00% 2KV	CN6011	1-537-770-21	TERMINAL BOARD, GROUND	
C6112	1-100-310-11	FILM 18000PF	3% 800V	CN6200	*1-793-236-11	PIN, CONNECTOR (PC BOARD) 14P	
C6116	1-163-021-91	CERAMIC CHIP 0.01UF	10.00% 50V	CN6202	*1-785-708-11	PIN, CONNECTOR (PC BOARD) 12P	
C6200	1-164-227-11	CERAMIC CHIP 0.022UF	10.00% 25V	CN6204	*1-785-706-11	PIN, CONNECTOR (PC BOARD) 10P	
C6202	1-112-242-21	ELECT 1500UF	20% 25V	CN6206	1-695-915-11	TAB (CONTACT)	
C6203	1-107-907-11	ELECT 22UF	20% 50V	CN6207	1-695-915-11	TAB (CONTACT)	
C6204	1-112-242-21	ELECT 1500UF	20% 25V	CN6211	1-537-770-21	TERMINAL BOARD, GROUND	
C6205	1-112-242-21	ELECT 1500UF	20% 25V	CN6214	1-537-770-21	TERMINAL BOARD, GROUND	
C6207	1-112-242-21	ELECT 1500UF	20% 25V	CN6216	1-537-770-21	TERMINAL BOARD, GROUND	
C6216	1-107-928-11	ELECT 4.7UF	20% 100V	CN6217	*1-785-701-11	PIN, CONNECTOR (PC BOARD) 3P	
C6217	1-112-229-21	ELECT 1500UF	20% 16V	< DIODE >			
C6305	1-107-826-11	CERAMIC CHIP 0.1UF	10.00% 16V	D6000	8-719-054-89	DIODE D15XB60	
C6306	1-162-927-11	CERAMIC CHIP 100PF	5.00% 50V	D6002	8-719-404-50	DIODE MA111-TX	
C6307	1-107-903-11	ELECT 2.2UF	20% 50V	D6003	8-719-404-50	DIODE MA111-TX	
C6308	1-107-904-11	ELECT 3.3UF	20% 50V	D6102	6-500-137-01	DIODE BAT54HT1	
C6309	1-107-910-11	ELECT 100UF	20% 50V	D6103	8-719-979-64	DIODE UF4005/23	
C6310	1-100-139-31	FILM 0.001UF	5% 630V	D6104	6-501-043-01	DIODE UMZ16NT106	
C6314	1-162-964-11	CERAMIC CHIP 0.001UF	10.00% 50V	D6105	6-501-043-01	DIODE UMZ16NT106	
C6315	1-165-729-31	ELECT 470UF	20% 16V	D6106	8-719-081-67	DIODE M1FM3	
				D6107	8-719-081-67	DIODE M1FM3	

Note : The components identified by shading and marked Δ are critical for safety. Replace only with the part numbers specified in the parts list.

G2A

REF.NO.	PART.NO	DESCRIPTION	REMARK	REF.NO.	PART.NO	DESCRIPTION	REMARK
D6108	8-719-041-97	DIODE MA113-(TX)		IC6402	6-709-368-01	IC MM1431ATT (CN)	
D6109	8-719-022-90	DIODE MA8160-M		IC6502	6-709-192-01	IC FA5501AN-D1-TE1	
D6200	8-719-057-96	DIODE D10SC6M-4012		< COIL >			
D6201	8-719-057-96	DIODE D10SC6M-4012		L6000	Δ 1-456-856-21	LINE FILTER COIL	
D6202	8-719-057-96	DIODE D10SC6M-4012		L6203	1-414-487-41	INDUCTOR	1UH
D6203	8-719-057-96	DIODE D10SC6M-4012		L6204	1-414-487-41	INDUCTOR	1UH
D6204	6-500-567-31	DIODE 10ERB20-TB3		L6207	1-457-239-11	INDUCTOR	4.7UH
D6205	6-500-567-31	DIODE 10ERB20-TB3		L6208	1-457-239-11	INDUCTOR	4.7UH
D6207	8-719-057-96	DIODE D10SC6M-4012		L6300	1-414-183-41	INDUCTOR	10UH
D6208	8-719-057-96	DIODE D10SC6M-4012		L6500	1-457-218-11	INDUCTOR	100UH
D6302	6-500-567-31	DIODE 10ERB20-TB3		L6502	1-457-141-21	INDUCTOR	175UH
D6303	6-500-567-31	DIODE 10ERB20-TB3		< PHOTOCOUPLER >			
D6304	6-500-849-01	DIODE ERA22-08KFLB		PH6000	Δ 6-600-187-01	PHOTO COUPLER	PC123Y22JOOF
D6305	6-500-567-31	DIODE 10ERB20-TB3		PH6100	6-600-187-01	PHOTO COUPLER	PC123Y22JOOF
D6306	8-719-510-02	DIODE D1NS4		PH6301	6-600-187-01	PHOTO COUPLER	PC123Y22JOOF
D6401	8-719-404-50	DIODE MA111-TX		PH6400	6-600-187-01	PHOTO COUPLER	PC123Y22JOOF
D6402	8-719-404-50	DIODE MA111-TX		PH6401	6-600-187-01	PHOTO COUPLER	PC123Y22JOOF
D6406	8-719-404-50	DIODE MA111-TX		PH6402	6-600-187-01	PHOTO COUPLER	PC123Y22JOOF
D6407	8-719-018-01	DIODE MA8220-TX		< TRANSISTOR >			
D6408	8-719-404-50	DIODE MA111-TX		Q6051	8-729-045-62	TRANSISTOR	2SK2158-T2B
D6452	8-719-404-50	DIODE MA111-TX		Q6100	6-551-297-01	TRANSISTOR	2SK3568 (LBS1SONY.Q)
D6456	8-719-404-50	DIODE MA111-TX		Q6101	6-551-297-01	TRANSISTOR	2SK3568 (LBS1SONY.Q)
D6504	8-719-404-50	DIODE MA111-TX		Q6400	8-729-804-41	TRANSISTOR	2SB1122-S
D6505	8-719-421-82	DIODE MA8043-M		Q6401	8-729-120-28	TRANSISTOR	2SC1623-L5L6
D6506	8-719-054-59	DIODE F5F05A60		Q6402	8-729-045-62	TRANSISTOR	2SK2158-T2B
D6507	8-719-404-50	DIODE MA111-TX		Q6403	8-729-600-22	TRANSISTOR	2SA1235-F
D6508	6-500-108-01	DIODE EP05FA20		Q6404	8-729-120-28	TRANSISTOR	2SC1623-L5L6
D6509	6-500-108-01	DIODE EP05FA20		Q6405	8-729-120-28	TRANSISTOR	2SC1623-L5L6
D6510	6-500-137-01	DIODE BAT54HT1		Q6406	8-729-120-28	TRANSISTOR	2SC1623-L5L6
D6511	8-719-404-50	DIODE MA111-TX		Q6408	8-729-120-28	TRANSISTOR	2SC1623-L5L6
D6512	8-719-404-50	DIODE MA111-TX		Q6409	8-729-120-28	TRANSISTOR	2SC1623-L5L6
D6551	8-719-404-50	DIODE MA111-TX		Q6454	8-729-600-22	TRANSISTOR	2SA1235-F
D6552	8-719-404-50	DIODE MA111-TX		Q6455	8-729-120-28	TRANSISTOR	2SC1623-L5L6
D6553	8-719-404-50	DIODE MA111-TX		Q6500	6-551-403-01	TRANSISTOR	2SK3797 (LBS1SONY)
< FUSE >				Q6501	8-729-820-90	TRANSISTOR	2SD1621-ST
F6000	Δ 1-576-233-51	FUSE	6.3A 250V	Q6502	8-729-804-41	TRANSISTOR	2SB1122-S
FH6000	Δ 1-533-223-11	FUSE HOLDER		Q6504	6-551-403-01	TRANSISTOR	2SK3797 (LBS1SONY)
FH6001	Δ 1-533-223-11	FUSE HOLDER		< RESISTOR >			
< FERRITE BEAD >				R6002	Δ 1-240-251-11	METAL	6.8 5% 10W
FB6100	1-412-911-11	FERRITE	0UH	R6003	1-247-752-11	CARBON	1K 5% 1/2W
FB6101	1-412-911-11	FERRITE	0UH	R6004	1-218-835-11	METAL CHIP	330 0.5% 1/10W
< IC >				R6016	1-535-143-71	LEAD, JUMPER	(7.5MM)
IC6100	6-707-749-01	IC CXD9841P		R6051	1-216-821-11	METAL CHIP	1K 5% 1/10W
IC6200	6-709-368-01	IC MM1431ATT (CN)		R6052	1-216-837-11	METAL CHIP	22K 5% 1/10W
IC6301	6-708-801-01	IC MIP2H2		R6101	1-249-385-11	CARBON	2.2 5% 1/4W
IC6302	6-709-442-01	IC MM1530ATT					
IC6401	6-709-368-01	IC MM1431ATT (CN)					

Note : The components identified by shading and marked Δ are critical for safety. Replace only with the part numbers specified in the parts list.

G2A

REF.NO.	PART.NO	DESCRIPTION	REMARK	REF.NO.	PART.NO	DESCRIPTION	REMARK
R6102	Δ 1-202-933-61	FUSIBLE	0.1 10% 1/2W	R6415	1-216-833-11	METAL CHIP	10K 5% 1/10W
R6103	1-218-823-11	METAL CHIP	100 0.5% 1/10W	R6416	1-216-837-11	METAL CHIP	22K 5% 1/10W
R6104	1-218-887-11	METAL CHIP	47K 0.5% 1/10W	R6417	1-216-821-11	METAL CHIP	1K 5% 1/10W
R6105	1-208-854-11	METAL CHIP	1M 0.5% 1/10W	R6418	1-216-845-11	METAL CHIP	100K 5% 1/10W
R6106	1-208-854-11	METAL CHIP	1M 0.5% 1/10W	R6419	1-216-837-11	METAL CHIP	22K 5% 1/10W
R6107	1-208-854-11	METAL CHIP	1M 0.5% 1/10W	R6420	1-216-833-11	METAL CHIP	10K 5% 1/10W
R6108	1-208-854-11	METAL CHIP	1M 0.5% 1/10W	R6421	1-216-864-11	SHORT CHIP	0
R6109	1-218-761-11	METAL CHIP	240K 0.5% 1/10W	R6422	1-218-887-11	METAL CHIP	47K 0.5% 1/10W
R6110	1-218-881-11	METAL CHIP	27K 0.5% 1/10W	R6425	1-216-809-11	METAL CHIP	100 5% 1/10W
R6111	1-218-873-11	METAL CHIP	12K 0.5% 1/10W	R6426	1-216-849-11	METAL CHIP	220K 5% 1/10W
R6114	1-211-985-11	METAL CHIP	47 0.5% 1/10W	R6427	1-218-889-11	METAL CHIP	56K 0.5% 1/10W
R6116	1-216-009-91	RES-CHIP	22 5% 1/10W	R6436	1-216-829-11	METAL CHIP	4.7K 5% 1/10W
R6117	1-216-009-91	RES-CHIP	22 5% 1/10W	R6437	1-216-821-11	METAL CHIP	1K 5% 1/10W
R6118	1-216-833-11	METAL CHIP	10K 5% 1/10W	R6441	1-216-841-11	METAL CHIP	47K 5% 1/10W
R6119	1-216-833-11	METAL CHIP	10K 5% 1/10W	R6442	1-216-833-11	METAL CHIP	10K 5% 1/10W
R6121	1-216-361-00	METAL OXIDE	0.22 5% 2W	R6443	1-216-833-11	METAL CHIP	10K 5% 1/10W
R6122	1-216-361-00	METAL OXIDE	0.22 5% 2W	R6444	1-216-833-11	METAL CHIP	10K 5% 1/10W
R6123	1-218-847-11	METAL CHIP	1K 0.5% 1/10W	R6451	1-216-833-11	METAL CHIP	10K 5% 1/10W
R6127	1-216-857-11	METAL CHIP	1M 5% 1/10W	R6452	1-218-847-11	METAL CHIP	1K 0.5% 1/10W
R6200	1-216-821-11	METAL CHIP	1K 5% 1/10W	R6453	1-216-833-11	METAL CHIP	10K 5% 1/10W
R6201	1-216-821-11	METAL CHIP	1K 5% 1/10W	R6454	1-216-829-11	METAL CHIP	4.7K 5% 1/10W
R6202	1-216-105-91	RES-CHIP	220K 5% 1/10W	R6455	1-218-903-11	METAL CHIP	220K 0.5% 1/10W
R6203	1-216-829-11	METAL CHIP	4.7K 5% 1/10W	R6456	1-218-859-11	METAL CHIP	3.3K 0.5% 1/10W
R6204	1-218-843-11	METAL CHIP	680 0.5% 1/10W	R6459	1-218-885-11	METAL CHIP	39K 0.5% 1/10W
R6205	1-218-865-11	METAL CHIP	5.6K 0.5% 1/10W	R6461	1-216-833-11	METAL CHIP	10K 5% 1/10W
R6207	1-218-847-11	METAL CHIP	1K 0.5% 1/10W	R6462	1-216-833-11	METAL CHIP	10K 5% 1/10W
R6208	1-249-377-11	CARBON	0.47 5% 1/4W	R6468	1-218-903-11	METAL CHIP	220K 0.5% 1/10W
R6226	1-249-389-11	CARBON	4.7 5% 1/4W	R6503	1-215-882-00	METAL OXIDE	22 5% 2W
R6300	Δ 1-212-958-00	FUSIBLE	10 5% 1/2W	R6512	1-218-907-11	METAL CHIP	330K 0.5% 1/10W
R6301	1-243-725-71	METAL OXIDE	100K 5% 1W	R6513	1-218-879-11	METAL CHIP	22K 0.5% 1/10W
R6302	1-218-865-11	METAL CHIP	5.6K 0.5% 1/10W	R6514	1-218-895-11	METAL CHIP	100K 0.5% 1/10W
R6303	1-249-385-11	CARBON	2.2 5% 1/4W	R6515	1-218-823-11	METAL CHIP	100 0.5% 1/10W
R6304	1-216-821-11	METAL CHIP	1K 5% 1/10W	R6526	1-211-989-11	METAL CHIP	68 0.5% 1/10W
R6305	1-216-827-11	METAL CHIP	3.3K 5% 1/10W	R6527	1-218-913-91	METAL CHIP	560K 0.5% 1/10W
R6306	1-216-805-11	METAL CHIP	47 5% 1/10W	R6528	1-218-879-11	METAL CHIP	22K 0.5% 1/10W
R6307	1-218-887-11	METAL CHIP	47K 0.5% 1/10W	R6529	1-216-864-11	SHORT CHIP	0
R6308	1-218-871-11	METAL CHIP	10K 0.5% 1/10W	R6530	1-219-729-61	METAL	0.33 10% 5W
R6309	1-218-867-11	METAL CHIP	6.8K 0.5% 1/10W	R6531	1-219-729-61	METAL	0.33 10% 5W
R6400	1-216-833-11	METAL CHIP	10K 5% 1/10W	R6532	1-216-864-11	SHORT CHIP	0
R6401	1-218-863-11	METAL CHIP	4.7K 0.5% 1/10W	R6533	1-216-833-11	METAL CHIP	10K 5% 1/10W
R6402	1-216-833-11	METAL CHIP	10K 5% 1/10W	R6534	1-218-823-11	METAL CHIP	100 0.5% 1/10W
R6403	1-218-887-11	METAL CHIP	47K 0.5% 1/10W	R6535	1-216-833-11	METAL CHIP	10K 5% 1/10W
R6405	1-216-829-11	METAL CHIP	4.7K 5% 1/10W	R6536	1-218-830-11	METAL CHIP	200 0.5% 1/10W
R6407	1-216-837-11	METAL CHIP	22K 5% 1/10W	R6537	1-249-389-11	CARBON	4.7 5% 1/4W
R6408	1-218-879-11	METAL CHIP	22K 0.5% 1/10W	R6538	1-249-405-11	CARBON	100 5% 1/4W
R6409	1-216-833-11	METAL CHIP	10K 5% 1/10W	R6539	1-218-830-11	METAL CHIP	200 0.5% 1/10W
R6410	1-216-821-11	METAL CHIP	1K 5% 1/10W	R6540	1-249-389-11	CARBON	4.7 5% 1/4W
R6412	1-216-833-11	METAL CHIP	10K 5% 1/10W	R6541	1-208-818-11	METAL CHIP	33K 0.5% 1/10W
R6413	1-218-863-11	METAL CHIP	4.7K 0.5% 1/10W	R6542	1-208-814-91	METAL CHIP	22K 0.5% 1/10W
R6414	1-216-833-11	METAL CHIP	10K 5% 1/10W	R6543	1-218-830-11	METAL CHIP	200 0.5% 1/10W

Note : The components identified by shading and marked Δ are critical for safety. Replace only with the part numbers specified in the parts list.

Note : The components identified by mark \square contain confidential information. Strictly follow the instructions when ever the components are repaired and/or replaced.

G2A **B2H**

REF.NO.	PART.NO	DESCRIPTION	REMARK	REF.NO.	PART.NO	DESCRIPTION	REMARK
R6544	1-218-830-11	METAL CHIP	200 0.5% 1/10W	C4024	1-100-591-91	CERAMIC CHIP 1UF	10% 25V
R6545	1-208-848-11	METAL CHIP	560K 0.5% 1/10W	C4025	1-162-964-11	CERAMIC CHIP 0.001UF	10.00% 50V
R6546	1-208-848-11	METAL CHIP	560K 0.5% 1/10W	C4026	1-107-826-11	CERAMIC CHIP 0.1UF	10.00% 16V
R6547	1-208-848-11	METAL CHIP	560K 0.5% 1/10W	C4027	1-162-964-11	CERAMIC CHIP 0.001UF	10.00% 50V
R6548	1-208-846-11	METAL CHIP	470K 0.5% 1/10W	C4028	1-107-826-11	CERAMIC CHIP 0.1UF	10.00% 16V
R6549	1-208-844-11	METAL CHIP	390K 0.5% 1/10W	C4029	1-162-912-11	CERAMIC CHIP 7PF	0.50PF 50V
R6550	1-218-875-11	METAL CHIP	15K 0.5% 1/10W	C4031	1-126-392-11	ELECT CHIP 100UF	20.00% 6.3V
R6551	1-249-393-11	CARBON	10 5% 1/4W	C4032	1-162-964-11	CERAMIC CHIP 0.001UF	10.00% 50V
R6552	1-216-809-11	METAL CHIP	100 5% 1/10W	C4033	1-100-566-91	CERAMIC CHIP 0.1UF	10.00% 25V
R6553 Δ	1-208-830-11	METAL CHIP	100K 0.5% 1/10W	C4035	1-126-392-11	ELECT CHIP 100UF	20.00% 6.3V
R6554	1-218-911-11	METAL CHIP	470K 0.5% 1/10W	C4036	1-100-566-91	CERAMIC CHIP 0.1UF	10.00% 25V
R6555	1-218-887-11	METAL CHIP	47K 0.5% 1/10W	C4037	1-162-964-11	CERAMIC CHIP 0.001UF	10.00% 50V
R6557	1-218-851-11	METAL CHIP	1.5K 0.5% 1/10W	C4038	1-162-964-11	CERAMIC CHIP 0.001UF	10.00% 50V
R6560	1-218-911-11	METAL CHIP	470K 0.5% 1/10W	C4039	1-107-826-11	CERAMIC CHIP 0.1UF	10.00% 16V
R6562 Δ	1-218-760-11	METAL CHIP	220K 0.5% 1/10W	C4040	1-107-826-11	CERAMIC CHIP 0.1UF	10.00% 16V
R6563 Δ	1-218-760-11	METAL CHIP	220K 0.5% 1/10W	C4042	1-165-908-11	CERAMIC CHIP 1UF	10% 10V
R6564 Δ	1-218-760-11	METAL CHIP	220K 0.5% 1/10W	C4046	1-100-591-91	CERAMIC CHIP 1UF	10% 25V
R6565 Δ	1-218-760-11	METAL CHIP	220K 0.5% 1/10W	C4047	1-162-964-11	CERAMIC CHIP 0.001UF	10.00% 50V
R6566	1-216-833-11	METAL CHIP	10K 5% 1/10W	C4048	1-107-826-11	CERAMIC CHIP 0.1UF	10.00% 16V
< RELAY >				C4049	1-100-566-91	CERAMIC CHIP 0.1UF	10.00% 25V
RY6003 Δ	1-755-579-11	RELAY, POWER		C4050	1-162-964-11	CERAMIC CHIP 0.001UF	10.00% 50V
< TRANSFORMER >				C4051	1-126-394-11	ELECT CHIP 10UF	20.00% 16V
T6102 Δ	1-443-983-11	CONVERTER TRANSFORMER (PIT)		C4052	1-107-826-11	CERAMIC CHIP 0.1UF	10.00% 16V
T6103 Δ	1-443-982-11	CONVERTER TRANSFORMER (PIT)		C4053	1-125-777-11	CERAMIC CHIP 0.1UF	10.00% 10V
T6301 Δ	1-443-984-11	CONVERTER TRANSFORMER (SBT)		C4054	1-100-566-91	CERAMIC CHIP 0.1UF	10.00% 25V
< VARISTOR >				C4055	1-100-566-91	CERAMIC CHIP 0.1UF	10.00% 25V
VD6000 Δ	1-804-996-21	VARISTOR		C4056	1-126-394-11	ELECT CHIP 10UF	20.00% 16V
VD6001 Δ	1-804-996-21	VARISTOR		C4057	1-107-826-11	CERAMIC CHIP 0.1UF	10.00% 16V
\square*A-1214-950-A B2H Board, Complete				C4058	1-162-964-11	CERAMIC CHIP 0.001UF	10.00% 50V
A5001	1-694-974-21	CONTACT TERMINAL		C4059	1-107-826-11	CERAMIC CHIP 0.1UF	10.00% 16V
< CAPACITOR >				C4060	1-162-964-11	CERAMIC CHIP 0.001UF	10.00% 50V
C4001	1-162-964-11	CERAMIC CHIP 0.001UF	10.00% 50V	C4061	1-126-394-11	ELECT CHIP 10UF	20.00% 16V
C4003	1-162-964-11	CERAMIC CHIP 0.001UF	10.00% 50V	C4062	1-100-566-91	CERAMIC CHIP 0.1UF	10.00% 25V
C4005	1-162-974-11	CERAMIC CHIP 0.01UF	50V	C4067	1-100-566-91	CERAMIC CHIP 0.1UF	10.00% 25V
C4009	1-126-396-11	ELECT CHIP 47UF	20.00% 16V	C4068	1-100-566-91	CERAMIC CHIP 0.1UF	10.00% 25V
C4011	1-162-970-11	CERAMIC CHIP 0.01UF	10.00% 25V	C4069	1-100-566-91	CERAMIC CHIP 0.1UF	10.00% 25V
C4012	1-162-970-11	CERAMIC CHIP 0.01UF	10.00% 25V	C4070	1-100-566-91	CERAMIC CHIP 0.1UF	10.00% 25V
C4013	1-100-566-91	CERAMIC CHIP 0.1UF	10.00% 25V	C4071	1-162-970-11	CERAMIC CHIP 0.01UF	10.00% 25V
C4015	1-162-970-11	CERAMIC CHIP 0.01UF	10.00% 25V	C4073	1-162-927-11	CERAMIC CHIP 100PF	5.00% 50V
C4017	1-107-826-11	CERAMIC CHIP 0.1UF	10.00% 16V	C4074	1-100-566-91	CERAMIC CHIP 0.1UF	10.00% 25V
C4018	1-117-681-11	ELECT CHIP 100UF	20.00% 16V	C4075	1-126-390-11	ELECT CHIP 22UF	20.00% 6.3V
C4021	1-100-566-91	CERAMIC CHIP 0.1UF	10.00% 25V	C4077	1-126-391-11	ELECT CHIP 47UF	20.00% 6.3V
C4022	1-126-206-11	ELECT CHIP 100UF	20.00% 6.3V	C4078	1-100-566-91	CERAMIC CHIP 0.1UF	10.00% 25V
C4023	1-115-456-21	DOUBLE LAYER 0.22F	5.5V	C4079	1-100-566-91	CERAMIC CHIP 0.1UF	10.00% 25V
				C4080	1-162-966-11	CERAMIC CHIP 0.0022UF	10.00% 50V
				C4081	1-165-908-11	CERAMIC CHIP 1UF	10% 10V
				C4083	1-115-416-11	CERAMIC CHIP 0.001UF	5.00% 25V
				C4084	1-107-826-11	CERAMIC CHIP 0.1UF	10.00% 16V
				C4085	1-162-964-11	CERAMIC CHIP 0.001UF	10.00% 50V
				C4086	1-126-394-11	ELECT CHIP 10UF	20.00% 16V

REF.NO.	PART.NO	DESCRIPTION	REMARK	REF.NO.	PART.NO	DESCRIPTION	REMARK
C4301	1-162-964-11	CERAMIC CHIP 0.001UF	10.00% 50V	C4537	1-162-970-11	CERAMIC CHIP 0.01UF	10.00% 25V
C4304	1-100-831-91	CERAMIC CHIP 0.001UF	2% 50V	C4540	1-100-566-91	CERAMIC CHIP 0.1UF	10.00% 25V
C4306	1-100-566-91	CERAMIC CHIP 0.1UF	10.00% 25V	C4541	1-126-392-11	ELECT CHIP 100UF	20.00% 6.3V
C4307	1-100-566-91	CERAMIC CHIP 0.1UF	10.00% 25V	C4542	1-126-392-11	ELECT CHIP 100UF	20.00% 6.3V
C4308	1-162-927-11	CERAMIC CHIP 100PF	5.00% 50V	C4543	1-100-566-91	CERAMIC CHIP 0.1UF	10.00% 25V
C4310	1-100-831-91	CERAMIC CHIP 0.001UF	2% 50V	C4545	1-135-595-11	ELECT 100UF	20% 6.3V
C4311	1-100-831-91	CERAMIC CHIP 0.001UF	2% 50V	C4549	1-165-673-21	ELECT CHIP 56UF	20% 10V
C4312	1-100-162-91	CERAMIC CHIP 1UF	50V	C4551	1-162-964-11	CERAMIC CHIP 0.001UF	10.00% 50V
C4402	1-162-964-11	CERAMIC CHIP 0.001UF	10.00% 50V	C4552	1-100-597-91	CERAMIC CHIP 0.1UF	10% 25V
C4403	1-162-964-11	CERAMIC CHIP 0.001UF	10.00% 50V	C4554	1-162-970-11	CERAMIC CHIP 0.01UF	10.00% 25V
C4404	1-127-573-11	CERAMIC CHIP 1UF	10% 16V	C4555	1-127-760-11	CERAMIC CHIP 4.7UF	10% 6.3V
C4405	1-127-573-11	CERAMIC CHIP 1UF	10% 16V	C4556	1-162-970-11	CERAMIC CHIP 0.01UF	10.00% 25V
C4406	1-100-566-91	CERAMIC CHIP 0.1UF	10.00% 25V	C4570	1-164-937-11	CERAMIC CHIP 0.001UF	10.00% 50V
C4407	1-100-566-91	CERAMIC CHIP 0.1UF	10.00% 25V	C5000	1-100-566-91	CERAMIC CHIP 0.1UF	10.00% 25V
C4408	1-127-573-11	CERAMIC CHIP 1UF	10% 16V	C5002	1-100-566-91	CERAMIC CHIP 0.1UF	10.00% 25V
C4409	1-127-573-11	CERAMIC CHIP 1UF	10% 16V	C5003	1-100-566-91	CERAMIC CHIP 0.1UF	10.00% 25V
C4410	1-162-927-11	CERAMIC CHIP 100PF	5.00% 50V	C5005	1-100-566-91	CERAMIC CHIP 0.1UF	10.00% 25V
C4411	1-162-927-11	CERAMIC CHIP 100PF	5.00% 50V	C5006	1-100-566-91	CERAMIC CHIP 0.1UF	10.00% 25V
C4412	1-165-908-11	CERAMIC CHIP 1UF	10% 10V	C5007	1-100-566-91	CERAMIC CHIP 0.1UF	10.00% 25V
C4413	1-162-970-11	CERAMIC CHIP 0.01UF	10.00% 25V	C5009	1-162-905-11	CERAMIC CHIP 1PF	0.25PF 50V
C4501	1-100-591-91	CERAMIC CHIP 1UF	10% 25V	C5010	1-100-566-91	CERAMIC CHIP 0.1UF	10.00% 25V
C4502	1-112-064-11	CERAMIC CHIP 2.2UF	10% 10V	C5011	1-100-566-91	CERAMIC CHIP 0.1UF	10.00% 25V
C4503	1-112-064-11	CERAMIC CHIP 2.2UF	10% 10V	C5012	1-100-566-91	CERAMIC CHIP 0.1UF	10.00% 25V
C4504	1-164-315-11	CERAMIC CHIP 470PF	5.00% 50V	C5013	1-100-566-91	CERAMIC CHIP 0.1UF	10.00% 25V
C4505	1-164-315-11	CERAMIC CHIP 470PF	5.00% 50V	C5014	1-100-566-91	CERAMIC CHIP 0.1UF	10.00% 25V
C4507	1-162-966-11	CERAMIC CHIP 0.0022UF	10.00% 50V	C5015	1-100-566-91	CERAMIC CHIP 0.1UF	10.00% 25V
C4508	1-162-966-11	CERAMIC CHIP 0.0022UF	10.00% 50V	C5016	1-100-566-91	CERAMIC CHIP 0.1UF	10.00% 25V
C4509	1-127-573-11	CERAMIC CHIP 1UF	10% 16V	C5017	1-100-566-91	CERAMIC CHIP 0.1UF	10.00% 25V
C4510	1-100-552-21	ELECT CHIP 10UF	20% 25V	C5018	1-100-566-91	CERAMIC CHIP 0.1UF	10.00% 25V
C4512	1-162-927-11	CERAMIC CHIP 100PF	5.00% 50V	C5019	1-100-566-91	CERAMIC CHIP 0.1UF	10.00% 25V
C4513	1-164-004-11	CERAMIC CHIP 0.1UF	10.00% 25V	C5020	1-100-566-91	CERAMIC CHIP 0.1UF	10.00% 25V
C4514	1-128-536-11	ELECT CHIP 100UF	20.00% 25V	C5021	1-100-566-91	CERAMIC CHIP 0.1UF	10.00% 25V
C4515	1-110-648-11	ELECT CHIP 220UF	20.00% 25V	C5022	1-162-905-11	CERAMIC CHIP 1PF	0.25PF 50V
C4516	1-110-648-11	ELECT CHIP 220UF	20.00% 25V	C5023	1-162-970-11	CERAMIC CHIP 0.01UF	10.00% 25V
C4517	1-100-591-91	CERAMIC CHIP 1UF	10% 25V	C5024	1-162-970-11	CERAMIC CHIP 0.01UF	10.00% 25V
C4518	1-100-591-91	CERAMIC CHIP 1UF	10% 25V	C5025	1-162-964-11	CERAMIC CHIP 0.001UF	10.00% 50V
C4519	1-164-004-11	CERAMIC CHIP 0.1UF	10.00% 25V	C5027	1-162-970-11	CERAMIC CHIP 0.01UF	10.00% 25V
C4520	1-100-591-91	CERAMIC CHIP 1UF	10% 25V	C5028	1-164-315-11	CERAMIC CHIP 470PF	5.00% 50V
C4521	1-164-004-11	CERAMIC CHIP 0.1UF	10.00% 25V	C5032	1-127-715-91	CERAMIC CHIP 0.22UF	10% 16V
C4524	1-162-970-11	CERAMIC CHIP 0.01UF	10.00% 25V	C5033	1-117-681-11	ELECT CHIP 100UF	20.00% 16V
C4525	1-125-827-91	CERAMIC CHIP 1UF	10.00% 25V	C5201	1-100-566-91	CERAMIC CHIP 0.1UF	10.00% 25V
C4526	1-125-827-91	CERAMIC CHIP 1UF	10.00% 25V	C5202	1-100-566-91	CERAMIC CHIP 0.1UF	10.00% 25V
C4527	1-162-970-11	CERAMIC CHIP 0.01UF	10.00% 25V	C5204	1-126-392-11	ELECT CHIP 100UF	20.00% 6.3V
C4528	1-112-794-11	ELECT CHIP 470UF	20% 16V	C5205	1-100-566-91	CERAMIC CHIP 0.1UF	10.00% 25V
C4530	1-165-673-21	ELECT CHIP 56UF	20% 10V	C5208	1-162-964-11	CERAMIC CHIP 0.001UF	10.00% 50V
C4531	1-165-673-21	ELECT CHIP 56UF	20% 10V	C5209	1-126-392-11	ELECT CHIP 100UF	20.00% 6.3V
C4532	1-112-794-11	ELECT CHIP 470UF	20% 16V	C5211	1-126-392-11	ELECT CHIP 100UF	20.00% 6.3V
C4534	1-164-004-11	CERAMIC CHIP 0.1UF	10.00% 25V	C5212	1-162-979-11	CERAMIC CHIP 0.0027UF	10.00% 50V
C4535	1-164-004-11	CERAMIC CHIP 0.1UF	10.00% 25V	C5213	1-162-979-11	CERAMIC CHIP 0.0027UF	10.00% 50V
C4536	1-162-970-11	CERAMIC CHIP 0.01UF	10.00% 25V	C5216	1-100-566-91	CERAMIC CHIP 0.1UF	10.00% 25V

REF.NO.	PART.NO	DESCRIPTION	REMARK	REF.NO.	PART.NO	DESCRIPTION	REMARK
C5217	1-100-566-91	CERAMIC CHIP 0.1UF	10.00% 25V	C5803	1-162-964-11	CERAMIC CHIP 0.001UF	10.00% 50V
C5218	1-100-566-91	CERAMIC CHIP 0.1UF	10.00% 25V	C5804	1-124-779-00	ELECT CHIP 10UF	20.00% 16V
C5219	1-126-392-11	ELECT CHIP 100UF	20.00% 6.3V	C5805	1-107-826-11	CERAMIC CHIP 0.1UF	10.00% 16V
C5220	1-162-964-11	CERAMIC CHIP 0.001UF	10.00% 50V	C5806	1-127-573-11	CERAMIC CHIP 1UF	10% 16V
C5221	1-100-566-91	CERAMIC CHIP 0.1UF	10.00% 25V	C5807	1-127-573-11	CERAMIC CHIP 1UF	10% 16V
C5222	1-100-566-91	CERAMIC CHIP 0.1UF	10.00% 25V	C5808	1-112-064-11	CERAMIC CHIP 2.2UF	10% 10V
C5224	1-126-392-11	ELECT CHIP 100UF	20.00% 6.3V	C5809	1-112-064-11	CERAMIC CHIP 2.2UF	10% 10V
C5225	1-162-960-11	CERAMIC CHIP 220PF	10.00% 50V	C5810	1-115-412-11	CERAMIC CHIP 680PF	5.00% 25V
C5226	1-100-566-91	CERAMIC CHIP 0.1UF	10.00% 25V	C5812	1-115-412-11	CERAMIC CHIP 680PF	5.00% 25V
C5230	1-162-964-11	CERAMIC CHIP 0.001UF	10.00% 50V	C5813	1-100-566-91	CERAMIC CHIP 0.1UF	10.00% 25V
C5231	1-100-566-91	CERAMIC CHIP 0.1UF	10.00% 25V	C5814	1-126-396-11	ELECT CHIP 47UF	20.00% 16V
C5234	1-162-964-11	CERAMIC CHIP 0.001UF	10.00% 50V	C5815	1-127-573-11	CERAMIC CHIP 1UF	10% 16V
C5236	1-162-964-11	CERAMIC CHIP 0.001UF	10.00% 50V	C5816	1-127-573-11	CERAMIC CHIP 1UF	10% 16V
C5237	1-162-964-11	CERAMIC CHIP 0.001UF	10.00% 50V	C5817	1-125-777-11	CERAMIC CHIP 0.1UF	10.00% 10V
C5239	1-100-566-91	CERAMIC CHIP 0.1UF	10.00% 25V	C5818	1-125-777-11	CERAMIC CHIP 0.1UF	10.00% 10V
C5240	1-162-964-11	CERAMIC CHIP 0.001UF	10.00% 50V	C5819	1-100-567-81	CERAMIC CHIP 0.01UF	10% 25V
C5241	1-126-392-11	ELECT CHIP 100UF	20.00% 6.3V	C5820	1-100-567-81	CERAMIC CHIP 0.01UF	10% 25V
C5246	1-162-964-11	CERAMIC CHIP 0.001UF	10.00% 50V	C5821	1-100-567-81	CERAMIC CHIP 0.01UF	10% 25V
C5250	1-162-964-11	CERAMIC CHIP 0.001UF	10.00% 50V	C5822	1-100-567-81	CERAMIC CHIP 0.01UF	10% 25V
C5252	1-100-566-91	CERAMIC CHIP 0.1UF	10.00% 25V	C5823	1-100-567-81	CERAMIC CHIP 0.01UF	10% 25V
C5253	1-126-392-11	ELECT CHIP 100UF	20.00% 6.3V	C5824	1-100-567-81	CERAMIC CHIP 0.01UF	10% 25V
C5254	1-126-392-11	ELECT CHIP 100UF	20.00% 6.3V	C5825	1-100-567-81	CERAMIC CHIP 0.01UF	10% 25V
C5255	1-100-566-91	CERAMIC CHIP 0.1UF	10.00% 25V	C5826	1-164-937-11	CERAMIC CHIP 0.001UF	10.00% 50V
C5256	1-100-566-91	CERAMIC CHIP 0.1UF	10.00% 25V	C5830	1-164-937-11	CERAMIC CHIP 0.001UF	10.00% 50V
C5257	1-100-566-91	CERAMIC CHIP 0.1UF	10.00% 25V	C5832	1-100-567-81	CERAMIC CHIP 0.01UF	10% 25V
C5258	1-100-566-91	CERAMIC CHIP 0.1UF	10.00% 25V	C5834	1-164-937-11	CERAMIC CHIP 0.001UF	10.00% 50V
C5259	1-100-566-91	CERAMIC CHIP 0.1UF	10.00% 25V	C5835	1-100-567-81	CERAMIC CHIP 0.01UF	10% 25V
C5260	1-100-566-91	CERAMIC CHIP 0.1UF	10.00% 25V	C5836	1-124-779-00	ELECT CHIP 10UF	20.00% 16V
C5262	1-100-566-91	CERAMIC CHIP 0.1UF	10.00% 25V	C5838	1-164-937-11	CERAMIC CHIP 0.001UF	10.00% 50V
C5265	1-162-964-11	CERAMIC CHIP 0.001UF	10.00% 50V	C5839	1-125-777-11	CERAMIC CHIP 0.1UF	10.00% 10V
C5269	1-162-964-11	CERAMIC CHIP 0.001UF	10.00% 50V	C5840	1-124-779-00	ELECT CHIP 10UF	20.00% 16V
C5270	1-162-964-11	CERAMIC CHIP 0.001UF	10.00% 50V	C5841	1-162-964-11	CERAMIC CHIP 0.001UF	10.00% 50V
C5271	1-162-964-11	CERAMIC CHIP 0.001UF	10.00% 50V	C5842	1-125-777-11	CERAMIC CHIP 0.1UF	10.00% 10V
C5273	1-162-964-11	CERAMIC CHIP 0.001UF	10.00% 50V				
C5274	1-162-964-11	CERAMIC CHIP 0.001UF	10.00% 50V			< CONNECTOR >	
C5278	1-100-566-91	CERAMIC CHIP 0.1UF	10.00% 25V	CN4000	1-819-390-51	FFC/FPC CONNECTOR (ZIF) 49P	
C5279	1-125-837-91	CERAMIC CHIP 1UF	10% 6.3V	CN4002	*1-819-447-11	HEADER ASSEMBLY FOR PWB 10P	
C5280	1-100-566-91	CERAMIC CHIP 0.1UF	10.00% 25V	CN4003	1-779-331-51	CONNECTOR, FFC/FPC 14P	
C5281	1-100-566-91	CERAMIC CHIP 0.1UF	10.00% 25V	CN4004	1-779-936-51	CONNECTOR, FFC/FPC 18P	
C5502	1-162-970-11	CERAMIC CHIP 0.01UF	10.00% 25V	CN4006	*1-819-336-11	HEADER ASSEMBLY FOR PWB 3P	
C5503	1-100-566-91	CERAMIC CHIP 0.1UF	10.00% 25V	CN4007	1-820-187-11	HEADER ASSEMBLY (PRINT PWB) 10P	
C5504	1-162-970-11	CERAMIC CHIP 0.01UF	10.00% 25V	CN4300	1-820-187-11	HEADER ASSEMBLY (PRINT PWB) 10P	
C5506	1-126-392-11	ELECT CHIP 100UF	20.00% 6.3V	CN4302	*1-820-189-11	HEADER ASSEMBLY (PRINT PWB) 12P	
C5507	1-162-968-11	CERAMIC CHIP 0.0047UF	10.00% 50V	CN4400	1-820-284-11	D SUB CONNECTOR	
C5508	1-162-970-11	CERAMIC CHIP 0.01UF	10.00% 25V	CN4500	1-820-186-11	HEADER ASSEMBLY (PRINT PWB) 9P	
C5510	1-162-927-11	CERAMIC CHIP 100PF	5.00% 50V	CN4501	1-820-184-11	HEADER ASSEMBLY (PRINT PWB) 7P	
C5512	1-100-566-91	CERAMIC CHIP 0.1UF	10.00% 25V	CN4700	1-820-255-51	FFC/FPC CONNECTOR (ZIF) 20P	
C5513	1-100-566-91	CERAMIC CHIP 0.1UF	10.00% 25V	CN5000	*1-820-235-11	HEADER ASSEMBLY 30P	
C5514	1-162-970-11	CERAMIC CHIP 0.01UF	10.00% 25V	CN5800	1-818-737-11	HDMI CONNECTOR	
C5802	1-162-964-11	CERAMIC CHIP 0.001UF	10.00% 50V	CN5801	1-818-737-11	HDMI CONNECTOR	

Note : The components identified by shading and marked Δ are critical for safety. Replace only with the part numbers specified in the parts list.

B2H

REF.NO.	PART.NO	DESCRIPTION	REMARK	REF.NO.	PART.NO	DESCRIPTION	REMARK
< DIODE >							
D4001	8-719-058-24	DIODE RB501V-40TE-17		D5824	1-802-255-11	ESD SUPPRESSOR	
D4002	8-719-404-50	DIODE MA111-TX		D5825	1-802-255-11	ESD SUPPRESSOR	
D4003	8-719-077-59	DIODE 1PS302		D5826	1-802-255-11	ESD SUPPRESSOR	
D4004	8-719-422-46	DIODE MA8056		D5827	1-802-255-11	ESD SUPPRESSOR	
D4005	8-719-422-46	DIODE MA8056		ET4503	1-780-336-11	EARTH TERMINAL	
D4301	8-719-064-03	DIODE HZU16B2TRF-E		ET4504	1-780-336-11	EARTH TERMINAL	
D4302	8-719-064-03	DIODE HZU16B2TRF-E		ET4505	1-780-336-11	EARTH TERMINAL	
D4400	8-719-422-46	DIODE MA8056		ET4506	1-780-336-11	EARTH TERMINAL	
D4401	8-719-422-46	DIODE MA8056		< FUSE >			
D4402	8-719-422-46	DIODE MA8056		F4500	Δ 1-576-603-21	FUSE	3.15A 24V
D4403	8-719-050-38	DIODE M1MA152WK-T1		F4501	Δ 1-576-603-21	FUSE	3.15A 24V
D4500	8-719-404-50	DIODE MA111-TX		< FERRITE BEAD >			
D4501	6-501-336-01	DIODE RSX201L-30TE25		FB4000	1-400-110-21	FERRITE	0UH
D4502	8-719-404-50	DIODE MA111-TX		FB4001	1-400-110-21	FERRITE	0UH
D4504	8-719-072-43	DIODE RB050L-40TE25		FB4002	1-400-807-21	FERRITE	0UH
D4505	8-719-072-43	DIODE RB050L-40TE25		FB4003	1-400-591-22	FERRITE	0UH
D4506	6-501-336-01	DIODE RSX201L-30TE25		FB4004	1-400-807-21	FERRITE	0UH
D4507	6-500-579-01	DIODE PTZ-TE25-6.8B		FB4005	1-400-807-21	FERRITE	0UH
D4508	8-719-073-69	DIODE PTZ-TE25-6.2A		FB4006	1-400-807-21	FERRITE	0UH
D4510	8-719-056-83	DIODE UDZ-TE-17-6.8B		FB4007	1-400-807-21	FERRITE	0UH
D4512	8-719-056-83	DIODE UDZ-TE-17-6.8B		FB4008	1-400-807-21	FERRITE	0UH
D4560	8-719-056-84	DIODE UDZ-TE-17-7.5B		FB4009	1-400-807-21	FERRITE	0UH
D4561	8-719-404-50	DIODE MA111-TX		FB4010	1-400-110-21	FERRITE	0UH
D4562	8-719-404-50	DIODE MA111-TX		FB4011	1-414-227-11	FERRITE	0UH
D4563	8-719-404-50	DIODE MA111-TX		FB4012	1-400-110-21	FERRITE	0UH
D5800	8-719-050-37	DIODE M1MA152WA-T1		FB4013	1-400-110-21	FERRITE	0UH
D5802	8-719-404-50	DIODE MA111-TX		FB4014	1-414-227-11	FERRITE	0UH
D5803	1-802-255-11	ESD SUPPRESSOR		FB4015	1-400-807-21	FERRITE	0UH
D5804	1-802-255-11	ESD SUPPRESSOR		FB4016	1-400-794-21	FERRITE	0UH
D5805	1-802-255-11	ESD SUPPRESSOR		FB4017	1-400-794-21	FERRITE	0UH
D5806	1-802-255-11	ESD SUPPRESSOR		FB4018	1-400-591-22	FERRITE	0UH
D5807	1-802-255-11	ESD SUPPRESSOR		FB4019	1-400-591-22	FERRITE	0UH
D5808	8-719-404-50	DIODE MA111-TX		FB4020	1-400-591-22	FERRITE	0UH
D5809	1-802-255-11	ESD SUPPRESSOR		FB4021	1-400-591-22	FERRITE	0UH
D5810	1-802-255-11	ESD SUPPRESSOR		FB4022	1-400-591-22	FERRITE	0UH
D5811	1-802-255-11	ESD SUPPRESSOR		FB4023	1-400-591-22	FERRITE	0UH
D5812	1-802-255-11	ESD SUPPRESSOR		FB4024	1-400-591-22	FERRITE	0UH
D5813	1-802-255-11	ESD SUPPRESSOR		FB4025	1-400-591-22	FERRITE	0UH
D5814	8-719-404-50	DIODE MA111-TX		FB4026	1-400-591-22	FERRITE	0UH
D5815	8-719-404-50	DIODE MA111-TX		FB4027	1-400-591-22	FERRITE	0UH
D5816	8-719-050-38	DIODE M1MA152WK-T1		FB4028	1-400-591-22	FERRITE	0UH
D5817	8-719-050-38	DIODE M1MA152WK-T1		FB4029	1-400-591-22	FERRITE	0UH
D5818	1-802-255-11	ESD SUPPRESSOR		FB4300	1-400-141-22	FERRITE	0UH
D5819	1-802-255-11	ESD SUPPRESSOR		FB4301	1-400-141-22	FERRITE	0UH
D5820	1-802-255-11	ESD SUPPRESSOR		FB4303	1-500-113-22	FERRITE	0UH
D5821	1-802-255-11	ESD SUPPRESSOR		FB4304	1-400-110-21	FERRITE	0UH
D5822	1-802-255-11	ESD SUPPRESSOR		FB4305	1-400-110-21	FERRITE	0UH
D5823	1-802-255-11	ESD SUPPRESSOR					

REF.NO.	PART.NO	DESCRIPTION	REMARK	REF.NO.	PART.NO	DESCRIPTION	REMARK
FB4306	1-400-110-21	FERRITE	OUH	IC4504	6-708-862-01	IC MM1662FTRE	
FB4400	1-469-100-21	FERRITE	OUH	IC5000	6-710-599-01	IC CXD9199GG-DW	
FB4401	1-469-100-21	FERRITE	OUH	IC5201	8-759-651-59	IC SN74CBTLV3245APWR	
FB4402	1-469-100-21	FERRITE	OUH	IC5202	8-759-651-59	IC SN74CBTLV3245APWR	
FB4403	1-400-141-22	FERRITE	OUH	IC5203	6-706-491-01	IC TC7SH86FU(T5RSOYJF)	
FB4405	1-469-100-21	FERRITE	OUH	IC5204	*6-703-108-01	IC SN74LVC2G04DCKR	
FB4500	1-400-794-21	FERRITE	OUH	IC5500	6-707-822-01	IC EM6A9320BI-5MG	
FB4501	1-400-794-21	FERRITE	OUH	IC5800	6-704-819-01	IC CS4335-KSZR	
FB4502	1-400-110-21	FERRITE	OUH	IC5801	6-704-001-01	IC BR24L02F-WE2	
FB4503	1-400-110-21	FERRITE	OUH	IC5802	6-704-001-01	IC BR24L02F-WE2	
FB4506	1-400-110-21	FERRITE	OUH	IC5803	6-708-758-01	IC PCA9517DP.118	
FB4507	1-400-110-21	FERRITE	OUH	IC5804	6-708-758-01	IC PCA9517DP.118	
FB4508	1-414-445-11	FERRITE	OUH	IC5805	8-759-596-34	IC SN74LV4053APWR	
FB4509	1-414-445-11	FERRITE	OUH	IC5806	8-753-255-97	IC CXB1441R-T4	
FB4510	1-414-445-11	FERRITE	OUH				
FB4511	1-400-591-22	FERRITE	OUH			< SOCKET >	
FB4512	1-400-591-22	FERRITE	OUH	J4400	1-820-638-11	JACK (SMALL TYPE)	
FB4513	1-400-591-22	FERRITE	OUH	J5800	1-820-765-11	PHONO JACK 2P	
FB4514	1-400-591-22	FERRITE	OUH			< COIL >	
FB5201	1-400-794-21	FERRITE	OUH	L4500	1-457-041-21	INDUCTOR	10UH
FB5800	1-469-094-21	FERRITE	OUH	L4501	1-416-740-11	INDUCTOR	10UH
	< FILTER >			L4502	1-416-740-11	INDUCTOR	10UH
FL4000	1-234-177-21	FERRITE	OUH	L4503	1-481-081-11	INDUCTOR	47UH
FL5201	1-234-177-21	FERRITE	OUH	L4504	1-481-080-11	INDUCTOR	22UH
FL5203	1-234-177-21	FERRITE	OUH	L4505	1-481-083-11	INDUCTOR	22UH
FL5206	1-234-177-21	FERRITE	OUH	L4506	1-456-786-21	INDUCTOR	47UH
FL5207	1-234-177-21	FERRITE	OUH	L4507	1-412-056-11	INDUCTOR	4.7UH
FL5500	1-234-177-21	FERRITE	OUH	L5000	1-456-984-11	INDUCTOR	OUH
FL5501	1-234-177-21	FERRITE	OUH	L5001	1-456-984-11	INDUCTOR	OUH
FL5800	1-234-177-21	FERRITE	OUH	L5002	1-456-984-11	INDUCTOR	OUH
FL5801	1-234-177-21	FERRITE	OUH	L5003	1-456-984-11	INDUCTOR	OUH
	< IC >			L5004	1-456-984-11	INDUCTOR	OUH
IC4000	8-759-460-79	IC BA09FP-E2		L5005	1-400-177-21	FERRITE	OUH
IC4001	6-706-419-01	IC LM393DT (A)		L5006	1-469-561-21	INDUCTOR	100UH
IC4002	6-709-517-01	IC S-35390A-J8T1G		L5201	1-400-794-21	FERRITE	OUH
IC4003	6-708-219-01	IC MB91305PMC-G-BNDE1		L5202	1-412-054-21	INDUCTOR	2.2UH
IC4004	6-703-175-01	IC PST3629UL		L5203	1-469-551-21	INDUCTOR	2.2UH
IC4005	6-709-512-01	IC S-1132B18-M5T1G		L5205	1-469-551-21	INDUCTOR	2.2UH
IC4006	6-710-121-01	IC M24256-BWMN6TP(A)		L5206	1-469-551-21	INDUCTOR	2.2UH
IC4007	6-706-815-01	IC TMP75AIDR		L5500	1-400-794-21	FERRITE	OUH
IC4008	6-707-867-01	IC TC74VHC132FT(EKJ)		L5501	1-400-794-21	FERRITE	OUH
IC4009	6-807-089-01	IC MX29LV160CTTI-70G-WAX2TE-01		L5800	1-469-555-21	INDUCTOR	10UH
IC4400	6-704-600-01	IC M24C02-WMN6T(B)		L5801	1-469-555-21	INDUCTOR	10UH
IC4401	6-707-846-01	IC TC74LCX14FT(EKJ)		L5802	1-457-057-21	INDUCTOR	OUH
IC4500	6-707-927-01	IC BD9775FV		L5803	1-457-057-21	INDUCTOR	OUH
IC4501	6-709-441-01	IC SI8008TM-TL		L5804	1-457-057-21	INDUCTOR	OUH
IC4502	6-709-441-01	IC SI8008TM-TL		L5805	1-457-057-21	INDUCTOR	OUH
				L5806	1-457-057-21	INDUCTOR	OUH
				L5807	1-457-057-21	INDUCTOR	OUH

Note : The components identified by shading and marked Δ are critical for safety. Replace only with the part numbers specified in the parts list.

B2H

REF.NO.	PART.NO	DESCRIPTION	REMARK	REF.NO.	PART.NO	DESCRIPTION	REMARK
L5808	1-457-057-21	INDUCTOR	0UH	Q5817	8-729-907-00	TRANSISTOR DTC114EU	
L5809	1-457-057-21	INDUCTOR	0UH	Q5818	8-729-907-00	TRANSISTOR DTC114EU	
< PROTECTOR MODULE >				< RESISTOR >			
PS4400 Δ	1-576-122-21	IC LINK	0.4A 72V	R4000	1-216-801-11	METAL CHIP 22 5%	1/10W
< TRANSISTOR >				R4001	1-216-801-11	METAL CHIP 22 5%	1/10W
Q4000	6-551-387-01	TRANSISTOR SSM6N16FU		R4002	1-216-801-11	METAL CHIP 22 5%	1/10W
Q4001	8-729-028-74	TRANSISTOR DTA114TUA-T106		R4003	1-216-864-11	SHORT CHIP 0	
Q4002	8-729-029-00	TRANSISTOR DTC115EUA-T106		R4004	1-216-864-11	SHORT CHIP 0	
Q4003	8-729-013-28	TRANSISTOR HN1B01FU-TE85R		R4005	1-216-801-11	METAL CHIP 22 5%	1/10W
Q4004	8-729-028-74	TRANSISTOR DTA114TUA-T106		R4006	1-216-801-11	METAL CHIP 22 5%	1/10W
Q4005	8-729-029-04	TRANSISTOR DTC123JUA-T106		R4007	1-216-801-11	METAL CHIP 22 5%	1/10W
Q4006	8-729-028-96	TRANSISTOR DTC114EUA-T106		R4008	1-216-864-11	SHORT CHIP 0	
Q4301	8-729-120-28	TRANSISTOR 2SC1623-L5L6		R4009	1-216-864-11	SHORT CHIP 0	
Q4400	8-729-120-28	TRANSISTOR 2SC1623-L5L6		R4010	1-216-864-11	SHORT CHIP 0	
Q4401	8-729-120-28	TRANSISTOR 2SC1623-L5L6		R4011	1-216-801-11	METAL CHIP 22 5%	1/10W
Q4500	8-729-046-04	TRANSISTOR FDS6690A		R4012	1-216-801-11	METAL CHIP 22 5%	1/10W
Q4501	6-550-828-01	TRANSISTOR RSQ035P03TR		R4013	1-216-801-11	METAL CHIP 22 5%	1/10W
Q4502	6-550-851-01	TRANSISTOR RSS050P03FTB		R4014	1-216-864-11	SHORT CHIP 0	
Q4503	*6-550-663-01	TRANSISTOR RSS100N03TB		R4015	1-216-864-11	SHORT CHIP 0	
Q4504	8-729-029-00	TRANSISTOR DTC115EUA-T106		R4016	1-218-990-81	SHORT CHIP 0	
Q4505	8-729-602-21	TRANSISTOR 2SC4154-F		R4017	1-218-990-81	SHORT CHIP 0	
Q4506	8-729-028-96	TRANSISTOR DTC114EUA-T106		R4018	1-208-683-11	METAL CHIP 1K 0.5%	1/16W
Q4560	8-729-028-96	TRANSISTOR DTC114EUA-T106		R4019	1-216-864-11	SHORT CHIP 0	
Q4561	8-729-028-96	TRANSISTOR DTC114EUA-T106		R4020	1-216-864-11	SHORT CHIP 0	
Q4562	8-729-028-96	TRANSISTOR DTC114EUA-T106		R4021	1-216-864-11	SHORT CHIP 0	
Q4563	8-729-028-96	TRANSISTOR DTC114EUA-T106		R4022	1-216-864-11	SHORT CHIP 0	
Q4564	8-729-028-96	TRANSISTOR DTC114EUA-T106		R4024	1-218-990-81	SHORT CHIP 0	
Q4565	8-729-028-96	TRANSISTOR DTC114EUA-T106		R4025	1-218-887-11	METAL CHIP 47K 0.5%	1/10W
Q5000	8-729-602-36	TRANSISTOR 2SA1602-F		R4026	1-216-864-11	SHORT CHIP 0	
Q5001	8-729-602-36	TRANSISTOR 2SA1602-F		R4027	1-218-863-11	METAL CHIP 4.7K 0.5%	1/10W
Q5800	8-729-600-22	TRANSISTOR 2SA1235-F		R4028	1-218-867-11	METAL CHIP 6.8K 0.5%	1/10W
Q5801	8-729-120-28	TRANSISTOR 2SC1623-L5L6		R4029	1-216-864-11	SHORT CHIP 0	
Q5802	8-729-120-28	TRANSISTOR 2SC1623-L5L6		R4030	1-218-965-11	RES-CHIP 10K 5%	1/16W
Q5803	6-551-364-01	TRANSISTOR DTC614TUT106		R4031	1-218-965-11	RES-CHIP 10K 5%	1/16W
Q5804	6-551-364-01	TRANSISTOR DTC614TUT106		R4032	1-218-965-11	RES-CHIP 10K 5%	1/16W
Q5805	8-729-120-28	TRANSISTOR 2SC1623-L5L6		R4033	1-216-841-11	METAL CHIP 47K 5%	1/10W
Q5806	8-729-028-96	TRANSISTOR DTC114EUA-T106		R4034	1-218-965-11	RES-CHIP 10K 5%	1/16W
Q5807	8-729-907-00	TRANSISTOR DTC114EU		R4035	1-218-965-11	RES-CHIP 10K 5%	1/16W
Q5808	8-729-907-00	TRANSISTOR DTC114EU		R4036	1-218-965-11	RES-CHIP 10K 5%	1/16W
Q5809	8-729-028-28	TRANSISTOR 2SK2036 (TE85L)		R4037	1-218-965-11	RES-CHIP 10K 5%	1/16W
Q5810	8-729-028-28	TRANSISTOR 2SK2036 (TE85L)		R4038	1-218-965-11	RES-CHIP 10K 5%	1/16W
Q5811	8-729-907-00	TRANSISTOR DTC114EU		R4039	1-218-965-11	RES-CHIP 10K 5%	1/16W
Q5812	8-729-907-00	TRANSISTOR DTC114EU		R4040	1-218-965-11	RES-CHIP 10K 5%	1/16W
Q5813	8-729-907-00	TRANSISTOR DTC114EU		R4041	1-218-941-81	RES-CHIP 100 5%	1/16W
Q5814	8-729-907-00	TRANSISTOR DTC114EU		R4042	1-218-990-81	SHORT CHIP 0	
Q5815	8-729-907-00	TRANSISTOR DTC114EU		R4045	1-216-813-11	METAL CHIP 220 5%	1/10W
Q5816	8-729-907-00	TRANSISTOR DTC114EU		R4046	1-218-945-11	RES-CHIP 220 5%	1/16W
				R4049	1-218-990-81	SHORT CHIP 0	

REF.NO.	PART.NO	DESCRIPTION	REMARK			REF.NO.	PART.NO	DESCRIPTION	REMARK		
R4051	1-218-965-11	RES-CHIP	10K	5%	1/16W	R4125	1-218-941-81	RES-CHIP	100	5%	1/16W
R4052	1-218-990-81	SHORT CHIP	0			R4126	1-218-941-81	RES-CHIP	100	5%	1/16W
R4055	1-218-965-11	RES-CHIP	10K	5%	1/16W	R4127	1-218-965-11	RES-CHIP	10K	5%	1/16W
R4056	1-218-965-11	RES-CHIP	10K	5%	1/16W	R4128	1-218-965-11	RES-CHIP	10K	5%	1/16W
R4057	1-218-990-81	SHORT CHIP	0			R4131	1-218-990-81	SHORT CHIP	0		
R4058	1-218-965-11	RES-CHIP	10K	5%	1/16W	R4132	1-218-965-11	RES-CHIP	10K	5%	1/16W
R4060	1-218-990-81	SHORT CHIP	0			R4134	1-218-990-81	SHORT CHIP	0		
R4062	1-218-990-81	SHORT CHIP	0			R4135	1-218-990-81	SHORT CHIP	0		
R4064	1-218-965-11	RES-CHIP	10K	5%	1/16W	R4136	1-218-965-11	RES-CHIP	10K	5%	1/16W
R4065	1-218-965-11	RES-CHIP	10K	5%	1/16W	R4137	1-218-949-11	RES-CHIP	470	5%	1/16W
R4066	1-216-864-11	SHORT CHIP	0			R4138	1-218-965-11	RES-CHIP	10K	5%	1/16W
R4067	1-216-864-11	SHORT CHIP	0			R4139	1-218-949-11	RES-CHIP	470	5%	1/16W
R4068	1-218-990-81	SHORT CHIP	0			R4140	1-218-990-81	SHORT CHIP	0		
R4070	1-218-871-11	METAL CHIP	10K	0.5%	1/10W	R4141	1-218-990-81	SHORT CHIP	0		
R4071	1-218-965-11	RES-CHIP	10K	5%	1/16W	R4142	1-218-949-11	RES-CHIP	470	5%	1/16W
R4072	1-218-871-11	METAL CHIP	10K	0.5%	1/10W	R4143	1-218-961-11	RES-CHIP	4.7K	5%	1/16W
R4073	1-218-871-11	METAL CHIP	10K	0.5%	1/10W	R4144	1-208-715-11	METAL CHIP	22K	0.5%	1/16W
R4074	1-218-965-11	RES-CHIP	10K	5%	1/16W	R4146	1-218-937-11	RES-CHIP	47	5%	1/16W
R4075	1-218-959-11	RES-CHIP	3.3K	5%	1/16W	R4147	1-218-990-81	SHORT CHIP	0		
R4079	1-218-941-81	RES-CHIP	100	5%	1/16W	R4150	1-218-937-11	RES-CHIP	47	5%	1/16W
R4080	1-218-941-81	RES-CHIP	100	5%	1/16W	R4152	1-216-864-11	SHORT CHIP	0		
R4081	1-218-941-81	RES-CHIP	100	5%	1/16W	R4153	1-218-990-81	SHORT CHIP	0		
R4082	1-218-941-81	RES-CHIP	100	5%	1/16W	R4156	1-216-813-11	METAL CHIP	220	5%	1/10W
R4083	1-218-933-11	RES-CHIP	22	5%	1/16W	R4157	1-216-864-11	SHORT CHIP	0		
R4084	1-218-941-81	RES-CHIP	100	5%	1/16W	R4159	1-216-864-11	SHORT CHIP	0		
R4085	1-218-933-11	RES-CHIP	22	5%	1/16W	R4160	1-216-849-11	METAL CHIP	220K	5%	1/10W
R4086	1-218-941-81	RES-CHIP	100	5%	1/16W	R4162	1-216-864-11	SHORT CHIP	0		
R4087	1-218-941-81	RES-CHIP	100	5%	1/16W	R4163	1-218-941-81	RES-CHIP	100	5%	1/16W
R4088	1-218-941-81	RES-CHIP	100	5%	1/16W	R4164	1-218-965-11	RES-CHIP	10K	5%	1/16W
R4092	1-218-965-11	RES-CHIP	10K	5%	1/16W	R4165	1-216-809-11	METAL CHIP	100	5%	1/10W
R4093	1-218-965-11	RES-CHIP	10K	5%	1/16W	R4300	1-216-864-11	SHORT CHIP	0		
R4095	1-218-965-11	RES-CHIP	10K	5%	1/16W	R4302	1-216-809-11	METAL CHIP	100	5%	1/10W
R4096	1-208-691-11	METAL CHIP	2.2K	0.5%	1/16W	R4303	1-216-864-11	SHORT CHIP	0		
R4099	1-218-941-81	RES-CHIP	100	5%	1/16W	R4307	1-218-990-81	SHORT CHIP	0		
R4101	1-218-941-81	RES-CHIP	100	5%	1/16W	R4308	1-218-990-81	SHORT CHIP	0		
R4103	1-218-941-81	RES-CHIP	100	5%	1/16W	R4309	1-218-965-11	RES-CHIP	10K	5%	1/16W
R4104	1-218-965-11	RES-CHIP	10K	5%	1/16W	R4310	1-218-965-11	RES-CHIP	10K	5%	1/16W
R4105	1-218-973-11	RES-CHIP	47K	5%	1/16W	R4311	1-216-853-11	METAL CHIP	470K	5%	1/10W
R4106	1-218-941-81	RES-CHIP	100	5%	1/16W	R4313	1-216-827-11	METAL CHIP	3.3K	5%	1/10W
R4107	1-218-965-11	RES-CHIP	10K	5%	1/16W	R4400	1-216-805-11	METAL CHIP	47	5%	1/10W
R4108	1-216-864-11	SHORT CHIP	0			R4401	1-216-805-11	METAL CHIP	47	5%	1/10W
R4109	1-218-965-11	RES-CHIP	10K	5%	1/16W	R4404	1-216-821-11	METAL CHIP	1K	5%	1/10W
R4110	1-218-965-11	RES-CHIP	10K	5%	1/16W	R4405	1-216-821-11	METAL CHIP	1K	5%	1/10W
R4111	1-218-941-81	RES-CHIP	100	5%	1/16W	R4408	1-216-853-11	METAL CHIP	470K	5%	1/10W
R4115	1-218-941-81	RES-CHIP	100	5%	1/16W	R4409	1-216-853-11	METAL CHIP	470K	5%	1/10W
R4116	1-218-965-11	RES-CHIP	10K	5%	1/16W	R4410	1-216-833-11	METAL CHIP	10K	5%	1/10W
R4119	1-218-990-81	SHORT CHIP	0			R4411	1-216-833-11	METAL CHIP	10K	5%	1/10W
R4121	1-218-990-81	SHORT CHIP	0			R4412	1-216-847-11	METAL CHIP	150K	5%	1/10W
R4123	1-208-886-81	METAL CHIP	910	0.5%	1/16W	R4413	1-216-847-11	METAL CHIP	150K	5%	1/10W
R4124	1-218-965-11	RES-CHIP	10K	5%	1/16W	R4414	1-216-805-11	METAL CHIP	47	5%	1/10W

REF.NO.	PART.NO	DESCRIPTION	REMARK			REF.NO.	PART.NO	DESCRIPTION	REMARK		
R4415	1-216-805-11	METAL CHIP	47	5%	1/10W	R4535	1-218-847-11	METAL CHIP	1K	0.5%	1/10W
R4416	1-216-821-11	METAL CHIP	1K	5%	1/10W	R4536	1-218-845-11	METAL CHIP	820	0.5%	1/10W
R4417	1-216-847-11	METAL CHIP	150K	5%	1/10W	R4538	1-218-879-11	METAL CHIP	22K	0.5%	1/10W
R4418	1-216-847-11	METAL CHIP	150K	5%	1/10W	R4539	1-216-295-91	SHORT CHIP	0		
R4419	1-218-827-11	METAL CHIP	150	0.5%	1/10W	R4540	1-216-864-11	SHORT CHIP	0		
R4420	1-218-827-11	METAL CHIP	150	0.5%	1/10W	R4541	1-216-295-91	SHORT CHIP	0		
R4421	1-218-827-11	METAL CHIP	150	0.5%	1/10W	R4542	1-216-295-91	SHORT CHIP	0		
R4422	1-216-821-11	METAL CHIP	1K	5%	1/10W	R4543	1-216-295-91	SHORT CHIP	0		
R4423	1-218-827-11	METAL CHIP	150	0.5%	1/10W	R4544	1-218-839-11	METAL CHIP	470	0.5%	1/10W
R4424	1-218-827-11	METAL CHIP	150	0.5%	1/10W	R4545	1-216-825-11	METAL CHIP	2.2K	5%	1/10W
R4425	1-216-821-11	METAL CHIP	1K	5%	1/10W	R4547	1-218-859-11	METAL CHIP	3.3K	0.5%	1/10W
R4426	1-218-827-11	METAL CHIP	150	0.5%	1/10W	R4548	1-218-867-11	METAL CHIP	6.8K	0.5%	1/10W
R4429	1-216-801-11	METAL CHIP	22	5%	1/10W	R4549	1-218-867-11	METAL CHIP	6.8K	0.5%	1/10W
R4430	1-216-801-11	METAL CHIP	22	5%	1/10W	R4550	1-218-859-11	METAL CHIP	3.3K	0.5%	1/10W
R4431	1-216-801-11	METAL CHIP	22	5%	1/10W	R4551	1-216-843-11	METAL CHIP	68K	5%	1/10W
R4432	1-216-845-11	METAL CHIP	100K	5%	1/10W	R4552	1-216-851-11	METAL CHIP	330K	5%	1/10W
R4436	1-218-933-11	RES-CHIP	22	5%	1/16W	R4553	1-216-833-11	METAL CHIP	10K	5%	1/10W
R4437	1-218-933-11	RES-CHIP	22	5%	1/16W	R4555	1-216-833-11	METAL CHIP	10K	5%	1/10W
R4500	1-218-877-11	METAL CHIP	18K	0.5%	1/10W	R4556	1-216-864-11	SHORT CHIP	0		
R4501	1-218-877-11	METAL CHIP	18K	0.5%	1/10W	R4558	1-216-835-11	METAL CHIP	15K	5%	1/10W
R4502	1-218-867-11	METAL CHIP	6.8K	0.5%	1/10W	R4560	1-218-965-11	RES-CHIP	10K	5%	1/16W
R4503	1-218-867-11	METAL CHIP	6.8K	0.5%	1/10W	R4561	1-218-867-11	METAL CHIP	6.8K	0.5%	1/10W
R4504	1-218-863-11	METAL CHIP	4.7K	0.5%	1/10W	R4562	1-218-965-11	RES-CHIP	10K	5%	1/16W
R4505	1-218-891-11	METAL CHIP	68K	0.5%	1/10W	R4563	1-218-965-11	RES-CHIP	10K	5%	1/16W
R4506	1-218-863-11	METAL CHIP	4.7K	0.5%	1/10W	R4564	1-218-867-11	METAL CHIP	6.8K	0.5%	1/10W
R4507	1-218-891-11	METAL CHIP	68K	0.5%	1/10W	R4565	1-218-965-11	RES-CHIP	10K	5%	1/16W
R4508	1-216-841-11	METAL CHIP	47K	5%	1/10W	R4566	1-216-864-11	SHORT CHIP	0		
R4509	1-216-841-11	METAL CHIP	47K	5%	1/10W	R4567	1-218-977-11	RES-CHIP	100K	5%	1/16W
R4510	1-218-875-11	METAL CHIP	15K	0.5%	1/10W	R4568	1-216-845-11	METAL CHIP	100K	5%	1/10W
R4511	1-218-879-11	METAL CHIP	22K	0.5%	1/10W	R4569	1-216-846-11	METAL CHIP	120K	5%	1/10W
R4512	1-216-835-11	METAL CHIP	15K	5%	1/10W	R4570	1-216-845-11	METAL CHIP	100K	5%	1/10W
R4513	1-218-882-11	METAL CHIP	30K	0.5%	1/10W	R4571	1-216-847-11	METAL CHIP	150K	5%	1/10W
R4514	1-216-821-11	METAL CHIP	1K	5%	1/10W	R4700	1-208-683-11	METAL CHIP	1K	0.5%	1/16W
R4515	1-216-815-11	METAL CHIP	330	5%	1/10W	R4710	1-216-864-11	SHORT CHIP	0		
R4516	1-216-809-11	METAL CHIP	100	5%	1/10W	R4716	1-216-864-11	SHORT CHIP	0		
R4517	1-216-809-11	METAL CHIP	100	5%	1/10W	R4717	1-216-864-11	SHORT CHIP	0		
R4519	1-216-835-11	METAL CHIP	15K	5%	1/10W	R5000	1-218-957-11	RES-CHIP	2.2K	5%	1/16W
R4520	1-216-864-11	SHORT CHIP	0			R5002	1-218-949-11	RES-CHIP	470	5%	1/16W
R4521	1-216-837-11	METAL CHIP	22K	5%	1/10W	R5003	1-218-990-81	SHORT CHIP	0		
R4522	1-216-864-11	SHORT CHIP	0			R5004	1-218-957-11	RES-CHIP	2.2K	5%	1/16W
R4523	1-216-864-11	SHORT CHIP	0			R5007	1-218-949-11	RES-CHIP	470	5%	1/16W
R4524	1-216-837-11	METAL CHIP	22K	5%	1/10W	R5008	1-218-990-81	SHORT CHIP	0		
R4525	1-216-864-11	SHORT CHIP	0			R5009	1-218-989-11	RES-CHIP	1M	5%	1/16W
R4526	1-216-864-11	SHORT CHIP	0			R5010	1-218-935-11	RES-CHIP	33	5%	1/16W
R4527	1-216-821-11	METAL CHIP	1K	5%	1/10W	R5011	1-218-941-81	RES-CHIP	100	5%	1/16W
R4528	1-216-821-11	METAL CHIP	1K	5%	1/10W	R5012	1-218-941-81	RES-CHIP	100	5%	1/16W
R4529	1-216-841-11	METAL CHIP	47K	5%	1/10W	R5013	1-218-941-81	RES-CHIP	100	5%	1/16W
R4530	1-216-841-11	METAL CHIP	47K	5%	1/10W	R5014	1-218-941-81	RES-CHIP	100	5%	1/16W
R4531	1-218-855-11	METAL CHIP	2.2K	0.5%	1/10W	R5016	1-218-941-81	RES-CHIP	100	5%	1/16W
R4532	1-218-843-11	METAL CHIP	680	0.5%	1/10W	R5017	1-218-941-81	RES-CHIP	100	5%	1/16W

REF.NO.	PART.NO	DESCRIPTION	REMARK			REF.NO.	PART.NO	DESCRIPTION	REMARK		
R5025	1-218-990-81	SHORT CHIP	0			R5807	1-216-821-11	METAL CHIP	1K	5%	1/10W
R5026	1-216-864-11	SHORT CHIP	0			R5808	1-216-864-11	SHORT CHIP	0		
R5027	1-216-864-11	SHORT CHIP	0			R5809	1-216-853-11	METAL CHIP	470K	5%	1/10W
R5029	1-218-965-11	RES-CHIP	10K	5%	1/16W	R5810	1-216-864-11	SHORT CHIP	0		
R5031	1-218-941-81	RES-CHIP	100	5%	1/16W	R5811	1-216-853-11	METAL CHIP	470K	5%	1/10W
R5039	1-218-990-81	SHORT CHIP	0			R5812	1-216-847-11	METAL CHIP	150K	5%	1/10W
R5040	1-218-990-81	SHORT CHIP	0			R5813	1-216-847-11	METAL CHIP	150K	5%	1/10W
R5042	1-218-961-11	RES-CHIP	4.7K	5%	1/16W	R5814	1-218-973-11	RES-CHIP	47K	5%	1/16W
R5043	1-218-961-11	RES-CHIP	4.7K	5%	1/16W	R5815	1-218-973-11	RES-CHIP	47K	5%	1/16W
R5044	1-218-961-11	RES-CHIP	4.7K	5%	1/16W	R5816	1-216-847-11	METAL CHIP	150K	5%	1/10W
R5045	1-218-961-11	RES-CHIP	4.7K	5%	1/16W	R5817	1-216-847-11	METAL CHIP	150K	5%	1/10W
R5046	1-218-957-11	RES-CHIP	2.2K	5%	1/16W	R5818	1-218-957-11	RES-CHIP	2.2K	5%	1/16W
R5047	1-218-957-11	RES-CHIP	2.2K	5%	1/16W	R5819	1-218-957-11	RES-CHIP	2.2K	5%	1/16W
R5206	1-216-295-91	SHORT CHIP	0			R5820	1-218-969-11	RES-CHIP	22K	5%	1/16W
R5210	1-218-961-11	RES-CHIP	4.7K	5%	1/16W	R5821	1-218-989-11	RES-CHIP	1M	5%	1/16W
R5211	1-218-990-81	SHORT CHIP	0			R5822	1-216-821-11	METAL CHIP	1K	5%	1/10W
R5212	1-218-973-11	RES-CHIP	47K	5%	1/16W	R5823	1-216-821-11	METAL CHIP	1K	5%	1/10W
R5214	1-218-933-11	RES-CHIP	22	5%	1/16W	R5824	1-218-973-11	RES-CHIP	47K	5%	1/16W
R5215	1-218-933-11	RES-CHIP	22	5%	1/16W	R5825	1-218-973-11	RES-CHIP	47K	5%	1/16W
R5218	1-216-864-11	SHORT CHIP	0			R5828	1-218-929-11	RES-CHIP	10	5%	1/16W
R5219	1-216-864-11	SHORT CHIP	0			R5829	1-208-683-11	METAL CHIP	1K	0.5%	1/16W
R5221	1-216-864-11	SHORT CHIP	0			R5830	1-218-929-11	RES-CHIP	10	5%	1/16W
R5222	1-216-864-11	SHORT CHIP	0			R5831	1-208-683-11	METAL CHIP	1K	0.5%	1/16W
R5223	1-218-965-11	RES-CHIP	10K	5%	1/16W	R5832	1-208-911-11	METAL CHIP	10K	0.5%	1/16W
R5224	1-218-990-81	SHORT CHIP	0			R5833	1-208-911-11	METAL CHIP	10K	0.5%	1/16W
R5225	1-218-965-11	RES-CHIP	10K	5%	1/16W	R5834	1-218-941-81	RES-CHIP	100	5%	1/16W
R5226	1-218-965-11	RES-CHIP	10K	5%	1/16W	R5835	1-218-941-81	RES-CHIP	100	5%	1/16W
R5500	1-400-794-21	FERRITE	0UH			R5836	1-218-941-81	RES-CHIP	100	5%	1/16W
R5503	1-218-847-11	METAL CHIP	1K	0.5%	1/10W	R5837	1-218-941-81	RES-CHIP	100	5%	1/16W
R5504	1-218-847-11	METAL CHIP	1K	0.5%	1/10W	R5838	1-218-961-11	RES-CHIP	4.7K	5%	1/16W
R5505	1-218-990-81	SHORT CHIP	0			R5839	1-218-961-11	RES-CHIP	4.7K	5%	1/16W
R5506	1-211-986-11	METAL CHIP	51	0.5%	1/10W	R5840	1-218-973-11	RES-CHIP	47K	5%	1/16W
R5507	1-218-990-81	SHORT CHIP	0			R5841	1-218-973-11	RES-CHIP	47K	5%	1/16W
R5508	1-218-933-11	RES-CHIP	22	5%	1/16W	R5842	1-218-973-11	RES-CHIP	47K	5%	1/16W
R5509	1-211-986-11	METAL CHIP	51	0.5%	1/10W	R5843	1-218-973-11	RES-CHIP	47K	5%	1/16W
R5510	1-218-933-11	RES-CHIP	22	5%	1/16W	R5844	1-218-973-11	RES-CHIP	47K	5%	1/16W
R5511	1-218-933-11	RES-CHIP	22	5%	1/16W	R5845	1-218-973-11	RES-CHIP	47K	5%	1/16W
R5512	1-218-933-11	RES-CHIP	22	5%	1/16W	R5846	1-218-941-81	RES-CHIP	100	5%	1/16W
R5513	1-218-933-11	RES-CHIP	22	5%	1/16W	R5847	1-218-990-81	SHORT CHIP	0		
R5514	1-218-933-11	RES-CHIP	22	5%	1/16W	R5848	1-218-990-81	SHORT CHIP	0		
R5515	1-218-933-11	RES-CHIP	22	5%	1/16W	R5849	1-218-990-81	SHORT CHIP	0		
R5516	1-218-933-11	RES-CHIP	22	5%	1/16W	R5850	1-218-941-81	RES-CHIP	100	5%	1/16W
R5517	1-218-933-11	RES-CHIP	22	5%	1/16W	R5851	1-218-990-81	SHORT CHIP	0		
R5518	1-218-933-11	RES-CHIP	22	5%	1/16W	R5852	1-218-990-81	SHORT CHIP	0		
R5519	1-218-933-11	RES-CHIP	22	5%	1/16W	R5854	1-218-929-11	RES-CHIP	10	5%	1/16W
R5800	1-216-805-11	METAL CHIP	47	5%	1/10W	R5855	1-218-929-11	RES-CHIP	10	5%	1/16W
R5801	1-216-805-11	METAL CHIP	47	5%	1/10W	R5856	1-218-929-11	RES-CHIP	10	5%	1/16W
R5802	1-216-805-11	METAL CHIP	47	5%	1/10W	R5857	1-218-929-11	RES-CHIP	10	5%	1/16W
R5803	1-216-805-11	METAL CHIP	47	5%	1/10W	R5858	1-218-929-11	RES-CHIP	10	5%	1/16W
R5806	1-216-821-11	METAL CHIP	1K	5%	1/10W	R5859	1-218-929-11	RES-CHIP	10	5%	1/16W

REF.NO.	PART.NO	DESCRIPTION	REMARK	REF.NO.	PART.NO	DESCRIPTION	REMARK
R5860	1-218-929-11	RES-CHIP	10 5% 1/16W	RB5501	1-234-370-21	RES, NETWORK 22	(1005X4)
R5861	1-218-929-11	RES-CHIP	10 5% 1/16W	RB5502	1-234-370-21	RES, NETWORK 22	(1005X4)
R5862	1-218-990-81	SHORT CHIP	0	RB5503	1-234-370-21	RES, NETWORK 22	(1005X4)
R5863	1-218-990-81	SHORT CHIP	0	RB5504	1-234-370-21	RES, NETWORK 22	(1005X4)
R5865	1-218-929-11	RES-CHIP	10 5% 1/16W	RB5505	1-234-370-21	RES, NETWORK 22	(1005X4)
R5866	1-218-929-11	RES-CHIP	10 5% 1/16W	RB5506	1-234-370-21	RES, NETWORK 22	(1005X4)
R5867	1-218-929-11	RES-CHIP	10 5% 1/16W	RB5507	1-234-370-21	RES, NETWORK 22	(1005X4)
R5868	1-218-929-11	RES-CHIP	10 5% 1/16W	RB5508	1-234-370-21	RES, NETWORK 22	(1005X4)
R5869	1-218-929-11	RES-CHIP	10 5% 1/16W	RB5509	1-234-370-21	RES, NETWORK 22	(1005X4)
R5870	1-218-929-11	RES-CHIP	10 5% 1/16W	RB5510	1-234-370-21	RES, NETWORK 22	(1005X4)
R5871	1-218-929-11	RES-CHIP	10 5% 1/16W	RB5511	1-234-370-21	RES, NETWORK 22	(1005X4)
R5872	1-218-929-11	RES-CHIP	10 5% 1/16W				
R5873	1-218-990-81	SHORT CHIP	0			< VARISTOR >	
R5874	1-218-961-11	RES-CHIP	4.7K 5% 1/16W	VD4400	1-802-078-11	VARISTOR (SMD)	
R5875	1-218-961-11	RES-CHIP	4.7K 5% 1/16W	VD4401	1-802-078-11	VARISTOR (SMD)	
R5876	1-218-961-11	RES-CHIP	4.7K 5% 1/16W	VD4402	1-802-078-11	VARISTOR (SMD)	
R5877	1-218-961-11	RES-CHIP	4.7K 5% 1/16W	VD4403	1-802-078-11	VARISTOR (SMD)	
R5878	1-218-965-11	RES-CHIP	10K 5% 1/16W	VD4404	1-802-078-11	VARISTOR (SMD)	
R5879	1-218-965-11	RES-CHIP	10K 5% 1/16W	VD4405	1-802-078-11	VARISTOR (SMD)	
R5880	1-218-965-11	RES-CHIP	10K 5% 1/16W	VD4406	1-802-078-11	VARISTOR (SMD)	
R5881	1-218-937-11	RES-CHIP	47 5% 1/16W	VD5800	1-802-078-11	VARISTOR (SMD)	
R5882	1-218-937-11	RES-CHIP	47 5% 1/16W	VD5801	1-802-078-11	VARISTOR (SMD)	
R5883	1-218-937-11	RES-CHIP	47 5% 1/16W			< CRYSTAL >	
R5892	1-218-951-11	RES-CHIP	680 5% 1/16W	X4000	1-813-784-21	VIBRATOR, CRYSTAL	
R5893	1-218-937-11	RES-CHIP	47 5% 1/16W	X4002	1-813-070-21	PIEZOELECTRIC OSCILLATOR	
R5894	1-218-937-11	RES-CHIP	47 5% 1/16W	X5000	1-813-773-11	VIBRATOR, CRYSTAL	
R5895	1-218-937-11	RES-CHIP	47 5% 1/16W				
R5896	1-218-951-11	RES-CHIP	680 5% 1/16W				
R5897	1-208-699-11	METAL CHIP	4.7K 0.5% 1/16W				
R5898	1-218-965-11	RES-CHIP	10K 5% 1/16W				
R5899	1-218-951-11	RES-CHIP	680 5% 1/16W				
R5900	1-218-937-11	RES-CHIP	47 5% 1/16W				
R5901	1-218-937-11	RES-CHIP	47 5% 1/16W				
R5902	1-216-295-91	SHORT CHIP	0				
R5906	1-216-864-11	SHORT CHIP	0				
		< RESISTOR CHIP >					
RB4000	1-234-372-11	RES, NETWORK	100 (1005X4)				
RB4001	1-234-372-11	RES, NETWORK	100 (1005X4)				
RB4002	1-234-372-11	RES, NETWORK	100 (1005X4)				
RB4003	1-234-378-21	RES, NETWORK	10K (1005X4)				
RB4004	1-234-378-21	RES, NETWORK	10K (1005X4)				
RB4700	1-234-375-21	RES, NETWORK	1K (1005X4)				
RB4701	1-234-375-21	RES, NETWORK	1K (1005X4)				
RB5000	1-234-795-21	RES, NETWORK	0X4 (2010)				
RB5001	1-234-795-21	RES, NETWORK	0X4 (2010)				
RB5201	1-234-372-11	RES, NETWORK	100 (1005X4)				
RB5202	1-234-372-11	RES, NETWORK	100 (1005X4)				
RB5203	1-234-372-11	RES, NETWORK	100 (1005X4)				
RB5500	1-234-370-21	RES, NETWORK	22 (1005X4)				
		< CAPACITOR >					
C2008	1-127-573-11	CERAMIC CHIP	1UF 10% 16V				
C2009	1-127-573-11	CERAMIC CHIP	1UF 10% 16V				
C2013	1-127-715-91	CERAMIC CHIP	0.22UF 10% 16V				
C2015	1-117-681-11	ELECT CHIP	100UF 20.00% 16V				
C2016	1-127-573-11	CERAMIC CHIP	1UF 10% 16V				
C2017	1-127-573-11	CERAMIC CHIP	1UF 10% 16V				
C2018	1-127-715-91	CERAMIC CHIP	0.22UF 10% 16V				
C2019	1-124-779-00	ELECT CHIP	10UF 20.00% 16V				
C2020	1-127-715-91	CERAMIC CHIP	0.22UF 10% 16V				
C2021	1-127-715-91	CERAMIC CHIP	0.22UF 10% 16V				
C2022	1-162-927-11	CERAMIC CHIP	100PF 5.00% 50V				
C2023	1-117-681-11	ELECT CHIP	100UF 20.00% 16V				
C2024	1-127-573-11	CERAMIC CHIP	1UF 10% 16V				
C2025	1-127-573-11	CERAMIC CHIP	1UF 10% 16V				
C2026	1-125-889-91	CERAMIC CHIP	2.2UF 10% 10V				
C2033	1-125-889-91	CERAMIC CHIP	2.2UF 10% 10V				
C2040	1-162-927-11	CERAMIC CHIP	100PF 5.00% 50V				
C2041	1-162-927-11	CERAMIC CHIP	100PF 5.00% 50V				
C2042	1-162-927-11	CERAMIC CHIP	100PF 5.00% 50V				

***A-1144-539-D AE Board, Complete**



REF.NO.	PART.NO	DESCRIPTION	REMARK	REF.NO.	PART.NO	DESCRIPTION	REMARK
C6001	1-107-826-11	CERAMIC CHIP 0.1UF	10.00% 16V	C7049	1-162-966-11	CERAMIC CHIP 0.0022UF	10.00% 50V
C6003	1-117-681-11	ELECT CHIP 100UF	20.00% 16V	C7050	1-162-966-11	CERAMIC CHIP 0.0022UF	10.00% 50V
C6005	1-164-227-11	CERAMIC CHIP 0.022UF	10.00% 25V	C7051	1-127-573-11	CERAMIC CHIP 1UF	10% 16V
C6011	1-107-826-11	CERAMIC CHIP 0.1UF	10.00% 16V	C7052	1-127-573-11	CERAMIC CHIP 1UF	10% 16V
C6014	1-162-968-11	CERAMIC CHIP 0.0047UF	10.00% 50V	C7053	1-126-394-11	ELECT CHIP 10UF	20.00% 16V
C6015	1-107-826-11	CERAMIC CHIP 0.1UF	10.00% 16V	C7054	1-126-394-11	ELECT CHIP 10UF	20.00% 16V
C6017	1-126-204-11	ELECT CHIP 47UF	20.00% 16V	C7055	1-100-566-91	CERAMIC CHIP 0.1UF	10.00% 25V
C6019	1-162-966-11	CERAMIC CHIP 0.0022UF	10.00% 50V	C7056	1-162-966-11	CERAMIC CHIP 0.0022UF	10.00% 50V
C6020	1-127-715-91	CERAMIC CHIP 0.22UF	10% 16V	C7057	1-126-396-11	ELECT CHIP 47UF	20.00% 16V
C6022	1-127-760-11	CERAMIC CHIP 4.7UF	10% 6.3V	C7060	1-115-416-11	CERAMIC CHIP 0.001UF	5.00% 25V
C6027	1-117-681-11	ELECT CHIP 100UF	20.00% 16V	C7061	1-115-416-11	CERAMIC CHIP 0.001UF	5.00% 25V
C7002	1-162-928-11	CERAMIC CHIP 120PF	5.00% 50V	C7062	1-115-416-11	CERAMIC CHIP 0.001UF	5.00% 25V
C7004	1-162-906-11	CERAMIC CHIP 1.5PF	0.25PF 50V	C7033	1-115-416-11	CERAMIC CHIP 0.001UF	5.00% 25V
C7005	1-162-906-11	CERAMIC CHIP 1.5PF	0.25PF 50V	C7064	1-115-416-11	CERAMIC CHIP 0.001UF	5.00% 25V
C7007	1-162-968-11	CERAMIC CHIP 0.0047UF	10.00% 50V	C7065	1-115-416-11	CERAMIC CHIP 0.001UF	5.00% 25V
C7008	1-162-966-11	CERAMIC CHIP 0.0022UF	10.00% 50V	C7072	1-128-536-11	ELECT CHIP 100UF	20.00% 25V
C7009	1-162-966-11	CERAMIC CHIP 0.0022UF	10.00% 50V	C7073	1-126-396-11	ELECT CHIP 47UF	20.00% 16V
C7010	1-164-004-11	CERAMIC CHIP 0.1UF	10.00% 25V	C7075	1-100-912-11	CERAMIC CHIP 1UF	10% 25V
C7011	1-126-396-11	ELECT CHIP 47UF	20.00% 16V	C7076	1-100-912-11	CERAMIC CHIP 1UF	10% 25V
C7012	1-162-927-11	CERAMIC CHIP 100PF	5.00% 50V	C7082	1-115-416-11	CERAMIC CHIP 0.001UF	5.00% 25V
C7013	1-162-927-11	CERAMIC CHIP 100PF	5.00% 50V	C7083	1-115-340-11	CERAMIC CHIP 0.22UF	10.00% 25V
C7014	1-162-962-11	CERAMIC CHIP 470PF	10.00% 50V	C7086	1-100-912-11	CERAMIC CHIP 1UF	10% 25V
C7015	1-162-960-11	CERAMIC CHIP 220PF	10.00% 50V	C7087	1-100-912-11	CERAMIC CHIP 1UF	10% 25V
C7017	1-127-573-11	CERAMIC CHIP 1UF	10% 16V	C7088	1-126-394-11	ELECT CHIP 10UF	20.00% 16V
C7018	1-127-573-11	CERAMIC CHIP 1UF	10% 16V	C7089	1-126-394-11	ELECT CHIP 10UF	20.00% 16V
C7019	1-126-394-11	ELECT CHIP 10UF	20.00% 16V	C7090	1-126-394-11	ELECT CHIP 10UF	20.00% 16V
C7020	1-100-566-91	CERAMIC CHIP 0.1UF	10.00% 25V	C7091	1-126-394-11	ELECT CHIP 10UF	20.00% 16V
C7021	1-127-573-11	CERAMIC CHIP 1UF	10% 16V	C7092	1-162-965-11	CERAMIC CHIP 0.0015UF	10.00% 50V
C7023	1-127-573-11	CERAMIC CHIP 1UF	10% 16V	C7093	1-164-217-11	CERAMIC CHIP 150PF	5.00% 50V
C7024	1-127-573-11	CERAMIC CHIP 1UF	10% 16V	C7094	1-164-217-11	CERAMIC CHIP 150PF	5.00% 50V
C7025	1-127-573-11	CERAMIC CHIP 1UF	10% 16V	C7095	1-162-965-11	CERAMIC CHIP 0.0015UF	10.00% 50V
C7027	1-127-573-11	CERAMIC CHIP 1UF	10% 16V	C7096	1-162-965-11	CERAMIC CHIP 0.0015UF	10.00% 50V
C7028	1-126-396-11	ELECT CHIP 47UF	20.00% 16V	C7097	1-164-217-11	CERAMIC CHIP 150PF	5.00% 50V
C7029	1-127-573-11	CERAMIC CHIP 1UF	10% 16V	C7098	1-164-217-11	CERAMIC CHIP 150PF	5.00% 50V
C7030	1-100-566-91	CERAMIC CHIP 0.1UF	10.00% 25V	C7099	1-162-965-11	CERAMIC CHIP 0.0015UF	10.00% 50V
C7033	1-127-573-11	CERAMIC CHIP 1UF	10% 16V	C7100	1-164-004-11	CERAMIC CHIP 0.1UF	10.00% 25V
C7034	1-124-779-00	ELECT CHIP 10UF	20.00% 16V	C7101	1-164-004-11	CERAMIC CHIP 0.1UF	10.00% 25V
C7035	1-127-573-11	CERAMIC CHIP 1UF	10% 16V	C7102	1-164-004-11	CERAMIC CHIP 0.1UF	10.00% 25V
C7036	1-127-573-11	CERAMIC CHIP 1UF	10% 16V	C7103	1-164-004-11	CERAMIC CHIP 0.1UF	10.00% 25V
C7037	1-127-573-11	CERAMIC CHIP 1UF	10% 16V	C7104	1-164-004-11	CERAMIC CHIP 0.1UF	10.00% 25V
C7038	1-126-394-11	ELECT CHIP 10UF	20.00% 16V	C7105	1-164-004-11	CERAMIC CHIP 0.1UF	10.00% 25V
C7039	1-100-566-91	CERAMIC CHIP 0.1UF	10.00% 25V	C7106	1-164-004-11	CERAMIC CHIP 0.1UF	10.00% 25V
C7040	1-164-004-11	CERAMIC CHIP 0.1UF	10.00% 25V	C7107	1-164-004-11	CERAMIC CHIP 0.1UF	10.00% 25V
C7042	1-162-966-11	CERAMIC CHIP 0.0022UF	10.00% 50V	C7108	1-164-004-11	CERAMIC CHIP 0.1UF	10.00% 25V
C7043	1-107-826-11	CERAMIC CHIP 0.1UF	10.00% 16V	C7109	1-162-959-11	CERAMIC CHIP 330PF	5.00% 50V
C7044	1-126-204-11	ELECT CHIP 47UF	20.00% 16V	C7110	1-162-959-11	CERAMIC CHIP 330PF	5.00% 50V
C7045	1-162-966-11	CERAMIC CHIP 0.0022UF	10.00% 50V	C7111	1-162-959-11	CERAMIC CHIP 330PF	5.00% 50V
C7046	1-162-966-11	CERAMIC CHIP 0.0022UF	10.00% 50V	C7112	1-162-959-11	CERAMIC CHIP 330PF	5.00% 50V
C7047	1-162-966-11	CERAMIC CHIP 0.0022UF	10.00% 50V	C7113	1-112-797-11	ELECT CHIP 470UF	20% 25V
C7048	1-162-966-11	CERAMIC CHIP 0.0022UF	10.00% 50V	C7114	1-112-800-11	ELECT CHIP 100UF	20% 35V

REF.NO.	PART.NO	DESCRIPTION	REMARK	REF.NO.	PART.NO	DESCRIPTION	REMARK
C7115	1-112-800-11	ELECT CHIP 100UF	20% 35V	C9032	1-115-416-11	CERAMIC CHIP 0.001UF	5.00% 25V
C7116	1-112-800-11	ELECT CHIP 100UF	20% 35V	C9043	1-127-573-11	CERAMIC CHIP 1UF	10% 16V
C7117	1-112-800-11	ELECT CHIP 100UF	20% 35V	C9044	1-127-573-11	CERAMIC CHIP 1UF	10% 16V
C7118	1-100-912-11	CERAMIC CHIP 1UF	10% 25V	C9045	1-100-597-91	CERAMIC CHIP 0.1UF	10% 25V
C7119	1-100-912-11	CERAMIC CHIP 1UF	10% 25V	C9046	1-100-597-91	CERAMIC CHIP 0.1UF	10% 25V
C7120	1-100-912-11	CERAMIC CHIP 1UF	10% 25V	C9047	1-125-889-91	CERAMIC CHIP 2.2UF	10% 10V
C7121	1-100-912-11	CERAMIC CHIP 1UF	10% 25V	C9048	1-125-889-91	CERAMIC CHIP 2.2UF	10% 10V
C7123	1-125-827-91	CERAMIC CHIP 1UF	10.00% 25V	C9049	1-127-573-11	CERAMIC CHIP 1UF	10% 16V
C7124	1-125-827-91	CERAMIC CHIP 1UF	10.00% 25V	C9050	1-127-573-11	CERAMIC CHIP 1UF	10% 16V
C7125	1-125-827-91	CERAMIC CHIP 1UF	10.00% 25V	C9051	1-127-573-11	CERAMIC CHIP 1UF	10% 16V
C7126	1-125-827-91	CERAMIC CHIP 1UF	10.00% 25V	C9052	1-127-573-11	CERAMIC CHIP 1UF	10% 16V
C7127	1-100-591-91	CERAMIC CHIP 1UF	10% 25V	C9057	1-162-923-11	CERAMIC CHIP 47PF	5.00% 50V
C7128	1-100-591-91	CERAMIC CHIP 1UF	10% 25V	C9058	1-162-923-11	CERAMIC CHIP 47PF	5.00% 50V
C7147	1-100-591-91	CERAMIC CHIP 1UF	10% 25V	C9060	1-162-962-11	CERAMIC CHIP 470PF	10.00% 50V
C7148	1-107-826-11	CERAMIC CHIP 0.1UF	10.00% 16V	C9061	1-162-962-11	CERAMIC CHIP 470PF	10.00% 50V
C7600	1-124-779-00	ELECT CHIP 10UF	20.00% 16V	C9065	1-162-923-11	CERAMIC CHIP 47PF	5.00% 50V
C7601	1-107-826-11	CERAMIC CHIP 0.1UF	10.00% 16V	C9066	1-162-923-11	CERAMIC CHIP 47PF	5.00% 50V
C7602	1-107-826-11	CERAMIC CHIP 0.1UF	10.00% 16V	C9067	1-162-923-11	CERAMIC CHIP 47PF	5.00% 50V
C7603	1-127-573-11	CERAMIC CHIP 1UF	10% 16V	C9068	1-162-923-11	CERAMIC CHIP 47PF	5.00% 50V
C7604	1-127-573-11	CERAMIC CHIP 1UF	10% 16V	C9069	1-162-923-11	CERAMIC CHIP 47PF	5.00% 50V
C7605	1-126-204-11	ELECT CHIP 47UF	20.00% 16V	C9070	1-162-923-11	CERAMIC CHIP 47PF	5.00% 50V
C7609	1-126-394-11	ELECT CHIP 10UF	20.00% 16V	C9501	1-115-416-11	CERAMIC CHIP 0.001UF	5.00% 25V
C7610	1-107-826-11	CERAMIC CHIP 0.1UF	10.00% 16V	C9502	1-115-416-11	CERAMIC CHIP 0.001UF	5.00% 25V
C7611	1-124-779-00	ELECT CHIP 10UF	20.00% 16V	< CONNECTOR >			
C7612	1-107-826-11	CERAMIC CHIP 0.1UF	10.00% 16V	CN7000	*1-819-461-11	HEADER ASSEMBLY FOR PWB 4P	
C7613	1-124-779-00	ELECT CHIP 10UF	20.00% 16V	CN7001	1-780-148-11	CLIP, SHIELD	
C7614	1-124-779-00	ELECT CHIP 10UF	20.00% 16V	CN7002	1-780-148-11	CLIP, SHIELD	
C7615	1-162-927-11	CERAMIC CHIP 100PF	5.00% 50V	CN7501	1-820-184-11	HEADER ASSEMBLY (PRINT PWB) 7P	
C7616	1-162-927-11	CERAMIC CHIP 100PF	5.00% 50V	CN7502	1-820-185-11	HEADER ASSEMBLY (PRINT PWB) 8P	
C7617	1-126-396-11	ELECT CHIP 47UF	20.00% 16V	CN7503	1-820-211-11	HEADER ASSEMBLY FOR PWB 5P	
C7618	1-126-396-11	ELECT CHIP 47UF	20.00% 16V	CN9001	1-820-192-11	HEADER ASSEMBLY (PRINT PWB)15P	
C7619	1-100-597-91	CERAMIC CHIP 0.1UF	10% 25V	CN9501	1-819-390-51	FFC/FPC CONNECTOR (ZIF) 49P	
C9001	1-162-962-11	CERAMIC CHIP 470PF	10.00% 50V	CN9502	1-820-186-11	HEADER ASSEMBLY (PRINT PWB) 9P	
C9003	1-162-962-11	CERAMIC CHIP 470PF	10.00% 50V	CN9521	1-780-336-11	EARTH TERMINAL	
C9005	1-162-962-11	CERAMIC CHIP 470PF	10.00% 50V	CN9522	1-780-336-11	EARTH TERMINAL	
C9007	1-162-962-11	CERAMIC CHIP 470PF	10.00% 50V	CN9523	1-780-336-11	EARTH TERMINAL	
C9009	1-164-227-11	CERAMIC CHIP 0.022UF	10.00% 25V	< DIODE >			
C9010	1-162-964-11	CERAMIC CHIP 0.001UF	10.00% 50V	D6001	8-719-074-43	DIODE BAS316-115	
C9011	1-164-227-11	CERAMIC CHIP 0.022UF	10.00% 25V	D7001	8-719-072-66	DIODE PDZ11B-115	
C9012	1-162-964-11	CERAMIC CHIP 0.001UF	10.00% 50V	D7004	6-500-334-01	DIODE MC2836-T112-1	
C9013	1-164-227-11	CERAMIC CHIP 0.022UF	10.00% 25V	D7005	8-719-074-43	DIODE BAS316-115	
C9014	1-162-964-11	CERAMIC CHIP 0.001UF	10.00% 50V	D7006	8-719-074-43	DIODE BAS316-115	
C9015	1-164-227-11	CERAMIC CHIP 0.022UF	10.00% 25V	D7007	8-719-074-43	DIODE BAS316-115	
C9016	1-162-964-11	CERAMIC CHIP 0.001UF	10.00% 50V	D7009	6-500-884-01	DIODE P6SMBJ30A-5	
C9021	1-128-992-21	ELECT CHIP 47UF	20% 25V	D7010	6-500-884-01	DIODE P6SMBJ30A-5	
C9027	1-162-970-11	CERAMIC CHIP 0.01UF	10.00% 25V	D7011	6-500-884-01	DIODE P6SMBJ30A-5	
C9028	1-128-992-21	ELECT CHIP 47UF	20% 25V	D7012	6-500-884-01	DIODE P6SMBJ30A-5	
C9029	1-128-992-21	ELECT CHIP 47UF	20% 25V				
C9030	1-128-992-21	ELECT CHIP 47UF	20% 25V				
C9031	1-128-992-21	ELECT CHIP 47UF	20% 25V				

Note : The components identified by shading and marked Δ are critical for safety. Replace only with the part numbers specified in the parts list.



REF.NO.	PART.NO	DESCRIPTION	REMARK	REF.NO.	PART.NO	DESCRIPTION	REMARK
D7013	8-719-074-43	DIODE BAS316-115				< SOCKET >	
D7602	6-500-334-01	DIODE MC2836-T112-1		J9001	1-695-549-11	SOCKET, PIN 21P	
D7603	6-500-334-01	DIODE MC2836-T112-1		J9002	1-695-549-11	SOCKET, PIN 21P	
D7604	8-719-074-43	DIODE BAS316-115		J9003	*1-819-358-11	PHONO JACK	
D7605	8-719-074-43	DIODE BAS316-115		J9004	1-819-354-11	PHONO JACK 5P	
D9001	8-719-070-63	DIODE PDZ10B-115				< COIL >	
D9002	8-719-072-68	DIODE PDZ13B-115		L2002	1-469-557-21	INDUCTOR	22UH
D9003	8-719-070-63	DIODE PDZ10B-115		L2003	1-469-555-21	INDUCTOR	10UH
D9004	8-719-070-63	DIODE PDZ10B-115		L6001	1-469-555-21	INDUCTOR	10UH
D9005	8-719-070-57	DIODE PDZ5.6B-115		L7001	1-412-990-41	INDUCTOR	8.2UH
D9007	8-719-070-57	DIODE PDZ5.6B-115		L7002	1-400-794-21	FERRITE	0UH
D9008	8-719-070-63	DIODE PDZ10B-115					
D9009	8-719-072-68	DIODE PDZ13B-115		L7004	1-400-794-21	FERRITE	0UH
D9010	8-719-070-63	DIODE PDZ10B-115		L7005	1-469-555-21	INDUCTOR	10UH
D9011	8-719-070-57	DIODE PDZ5.6B-115		L7006	1-400-794-21	FERRITE	0UH
D9012	8-719-070-63	DIODE PDZ10B-115		L7007	1-469-555-21	INDUCTOR	10UH
D9013	8-719-070-57	DIODE PDZ5.6B-115		L7008	1-481-083-11	INDUCTOR	22UH
D9015	8-719-070-57	DIODE PDZ5.6B-115					
D9016	8-719-070-63	DIODE PDZ10B-115		L7009	1-457-106-11	INDUCTOR	10UH
D9017	8-719-070-63	DIODE PDZ10B-115		L7010	1-457-106-11	INDUCTOR	10UH
D9018	8-719-070-63	DIODE PDZ10B-115		L7011	1-400-794-21	FERRITE	0UH
D9019	8-719-070-63	DIODE PDZ10B-115		L7012	1-400-794-21	FERRITE	0UH
D9020	8-719-070-63	DIODE PDZ10B-115		L7013	1-400-794-21	FERRITE	0UH
D9021	8-719-070-63	DIODE PDZ10B-115					
D9022	8-719-070-63	DIODE PDZ10B-115		L9001	1-469-555-21	INDUCTOR	10UH
D9023	8-719-070-63	DIODE PDZ10B-115		L9503	1-400-178-21	FERRITE	0UH
D9036	8-719-070-63	DIODE PDZ10B-115		L9504	1-400-178-21	FERRITE	0UH
D9037	8-719-070-63	DIODE PDZ10B-115		L9505	1-400-178-21	FERRITE	0UH
D9038	8-719-070-63	DIODE PDZ10B-115				< PROTECTOR MODULE >	
D9039	8-719-070-63	DIODE PDZ10B-115		PS7001 Δ	1-576-958-21	FUSE	4A 24V
		< FERRITE BEAD >				< TRANSISTOR >	
FB7000	1-400-089-21	FERRITE	0UH	Q2001	8-729-120-28	TRANSISTOR 2SC1623-L5L6	
FB7001	1-400-089-21	FERRITE	0UH	Q2002	8-729-120-28	TRANSISTOR 2SC1623-L5L6	
FB7002	1-400-089-21	FERRITE	0UH	Q6001	8-729-600-22	TRANSISTOR 2SA1235-F	
FB7003	1-400-089-21	FERRITE	0UH	Q6002	8-729-600-22	TRANSISTOR 2SA1235-F	
FB7004	1-400-040-22	FERRITE	0UH	Q6004	8-729-600-22	TRANSISTOR 2SA1235-F	
FB7005	1-400-040-22	FERRITE	0UH	Q6008	8-729-120-28	TRANSISTOR 2SC1623-L5L6	
FB7006	1-400-040-22	FERRITE	0UH	Q6009	8-729-120-28	TRANSISTOR 2SC1623-L5L6	
FB7007	1-400-040-22	FERRITE	0UH	Q7000	8-729-120-28	TRANSISTOR 2SC1623-L5L6	
FB7008	1-400-040-22	FERRITE	0UH	Q7001	8-729-600-22	TRANSISTOR 2SA1235-F	
FB9003	1-216-864-11	SHORT CHIP	0	Q7002	8-729-120-28	TRANSISTOR 2SC1623-L5L6	
		< IC >		Q7005	8-729-600-22	TRANSISTOR 2SA1235-F	
IC2001	8-752-089-33	IC CXA2069Q-TL		Q7007	8-729-029-14	TRANSISTOR DTC144EUA-T106	
IC7001	6-709-191-01	IC MSP4410K-QA-D6-501		Q7008	8-729-120-28	TRANSISTOR 2SC1623-L5L6	
IC7003	8-759-278-58	IC NJM4558V-TE2		Q7009	8-729-600-22	TRANSISTOR 2SA1235-F	
IC7007	6-709-285-01	IC M61571AFP-DF0T		Q7010	8-729-029-14	TRANSISTOR DTC144EUA-T106	
IC7601	8-759-278-58	IC NJM4558V-TE2		Q7011	8-729-029-14	TRANSISTOR DTC144EUA-T106	
IC7602	8-759-359-49	IC NJM3414AV (TE2)		Q7012	8-729-141-73	TRANSISTOR 2SC3624A-T1L15L16	
				Q7013	8-729-141-73	TRANSISTOR 2SC3624A-T1L15L16	

REF.NO.	PART.NO	DESCRIPTION	REMARK	REF.NO.	PART.NO	DESCRIPTION	REMARK
Q7014	8-729-600-22	TRANSISTOR 2SA1235-F		R6001	1-216-825-11	METAL CHIP 2.2K 5%	1/10W
Q7015	8-729-600-22	TRANSISTOR 2SA1235-F		R6002	1-216-809-11	METAL CHIP 100 5%	1/10W
Q7016	8-729-600-22	TRANSISTOR 2SA1235-F		R6003	1-216-864-11	SHORT CHIP 0	
Q7017	8-729-600-22	TRANSISTOR 2SA1235-F		R6004	1-218-855-11	METAL CHIP 2.2K 0.5%	1/10W
Q7018	8-729-120-28	TRANSISTOR 2SC1623-L5L6		R6009	1-216-829-11	METAL CHIP 4.7K 5%	1/10W
Q7019	8-729-029-14	TRANSISTOR DTC144EUA-T106		R6017	1-216-857-11	METAL CHIP 1M 5%	1/10W
Q7020	8-729-029-14	TRANSISTOR DTC144EUA-T106		R6021	1-216-829-11	METAL CHIP 4.7K 5%	1/10W
Q7021	8-729-028-96	TRANSISTOR DTC114EUA-T106		R6025	1-218-857-11	METAL CHIP 2.7K 0.5%	1/10W
Q7022	8-729-028-96	TRANSISTOR DTC114EUA-T106		R6028	1-218-861-11	METAL CHIP 3.9K 0.5%	1/10W
Q7602	8-729-600-22	TRANSISTOR 2SA1235-F		R6031	1-216-864-11	SHORT CHIP 0	
Q7603	8-729-141-73	TRANSISTOR 2SC3624A-T1L15L16		R6032	1-216-857-11	METAL CHIP 1M 5%	1/10W
Q7604	8-729-141-73	TRANSISTOR 2SC3624A-T1L15L16		R6034	1-216-864-11	SHORT CHIP 0	
Q7605	8-729-120-28	TRANSISTOR 2SC1623-L5L6		R6037	1-216-821-11	METAL CHIP 1K 5%	1/10W
Q7606	8-729-141-73	TRANSISTOR 2SC3624A-T1L15L16		R6039	1-216-815-11	METAL CHIP 330 5%	1/10W
Q7607	8-729-141-73	TRANSISTOR 2SC3624A-T1L15L16		R6040	1-216-864-11	SHORT CHIP 0	
Q7608	8-729-029-14	TRANSISTOR DTC144EUA-T106		R6051	1-216-864-11	SHORT CHIP 0	
Q7609	8-729-600-22	TRANSISTOR 2SA1235-F		R6940	1-216-864-11	SHORT CHIP 0	
Q7610	8-729-120-28	TRANSISTOR 2SC1623-L5L6		R6942	1-216-864-11	SHORT CHIP 0	
Q7611	8-729-029-14	TRANSISTOR DTC144EUA-T106		R6943	1-216-864-11	SHORT CHIP 0	
Q9001	8-729-120-28	TRANSISTOR 2SC1623-L5L6		R6946	1-216-864-11	SHORT CHIP 0	
Q9002	8-729-120-28	TRANSISTOR 2SC1623-L5L6		R6947	1-216-864-11	SHORT CHIP 0	
		< RESISTOR >		R6948	1-216-864-11	SHORT CHIP 0	
R2002	1-216-821-11	METAL CHIP 1K 5%	1/10W	R6962	1-216-864-11	SHORT CHIP 0	
R2003	1-216-821-11	METAL CHIP 1K 5%	1/10W	R6963	1-216-864-11	SHORT CHIP 0	
R2004	1-216-864-11	SHORT CHIP 0		R7000	1-216-864-11	SHORT CHIP 0	
R2005	1-216-864-11	SHORT CHIP 0		R7001	1-216-821-11	METAL CHIP 1K 5%	1/10W
R2006	1-216-809-11	METAL CHIP 100 5%	1/10W	R7004	1-216-841-11	METAL CHIP 47K 5%	1/10W
R2007	1-216-809-11	METAL CHIP 100 5%	1/10W	R7007	1-216-805-11	METAL CHIP 47 5%	1/10W
R2010	1-216-864-11	SHORT CHIP 0		R7008	1-216-864-11	SHORT CHIP 0	
R2011	1-216-864-11	SHORT CHIP 0		R7010	1-216-821-11	METAL CHIP 1K 5%	1/10W
R2012	1-216-864-11	SHORT CHIP 0		R7011	1-216-845-11	METAL CHIP 100K 5%	1/10W
R2014	1-216-864-11	SHORT CHIP 0		R7012	1-216-864-11	SHORT CHIP 0	
R2015	1-216-864-11	SHORT CHIP 0		R7014	1-216-841-11	METAL CHIP 47K 5%	1/10W
R2017	1-216-864-11	SHORT CHIP 0		R7015	1-216-841-11	METAL CHIP 47K 5%	1/10W
R2019	1-216-809-11	METAL CHIP 100 5%	1/10W	R7017	1-216-833-11	METAL CHIP 10K 5%	1/10W
R2020	1-216-809-11	METAL CHIP 100 5%	1/10W	R7018	1-400-499-21	FERRITE 0UH	
R2023	1-216-821-11	METAL CHIP 1K 5%	1/10W	R7019	1-400-499-21	FERRITE 0UH	
R2024	1-216-821-11	METAL CHIP 1K 5%	1/10W	R7020	1-216-841-11	METAL CHIP 47K 5%	1/10W
R2025	1-216-864-11	SHORT CHIP 0		R7022	1-216-864-11	SHORT CHIP 0	
R2026	1-216-864-11	SHORT CHIP 0		R7025	1-216-864-11	SHORT CHIP 0	
R2027	1-216-864-11	SHORT CHIP 0		R7031	1-218-863-11	METAL CHIP 4.7K 0.5%	1/10W
R2028	1-216-864-11	SHORT CHIP 0		R7032	1-218-875-11	METAL CHIP 15K 0.5%	1/10W
R2029	1-216-864-11	SHORT CHIP 0		R7033	1-218-863-11	METAL CHIP 4.7K 0.5%	1/10W
R2030	1-216-809-11	METAL CHIP 100 5%	1/10W	R7034	1-218-875-11	METAL CHIP 15K 0.5%	1/10W
R2035	1-216-809-11	METAL CHIP 100 5%	1/10W	R7035	1-216-845-11	METAL CHIP 100K 5%	1/10W
R2037	1-216-817-11	METAL CHIP 470 5%	1/10W	R7037	1-216-833-11	METAL CHIP 10K 5%	1/10W
R2038	1-216-817-11	METAL CHIP 470 5%	1/10W	R7039	1-218-873-11	METAL CHIP 12K 0.5%	1/10W
R2039	1-216-864-11	SHORT CHIP 0		R7040	1-218-875-11	METAL CHIP 15K 0.5%	1/10W
				R7041	1-216-833-11	METAL CHIP 10K 5%	1/10W
				R7045	1-216-833-11	METAL CHIP 10K 5%	1/10W



REF.NO.	PART.NO	DESCRIPTION	REMARK	REF.NO.	PART.NO	DESCRIPTION	REMARK
R7047	1-216-833-11	METAL CHIP	10K 5% 1/10W	R7143	1-216-845-11	METAL CHIP	100K 5% 1/10W
R7049	1-216-841-11	METAL CHIP	47K 5% 1/10W	R7144	1-216-845-11	METAL CHIP	100K 5% 1/10W
R7050	1-218-863-11	METAL CHIP	4.7K 0.5% 1/10W	R7145	1-216-845-11	METAL CHIP	100K 5% 1/10W
R7054	1-216-841-11	METAL CHIP	47K 5% 1/10W	R7146	1-216-845-11	METAL CHIP	100K 5% 1/10W
R7055	1-216-845-11	METAL CHIP	100K 5% 1/10W	R7147	1-216-845-11	METAL CHIP	100K 5% 1/10W
R7056	1-218-863-11	METAL CHIP	4.7K 0.5% 1/10W	R7152	1-216-833-11	METAL CHIP	10K 5% 1/10W
R7057	1-218-875-11	METAL CHIP	15K 0.5% 1/10W	R7153	1-216-845-11	METAL CHIP	100K 5% 1/10W
R7059	1-218-875-11	METAL CHIP	15K 0.5% 1/10W	R7154	1-216-845-11	METAL CHIP	100K 5% 1/10W
R7061	1-218-871-11	METAL CHIP	10K 0.5% 1/10W	R7155	1-216-864-11	SHORT CHIP	0
R7062	1-218-869-11	METAL CHIP	8.2K 0.5% 1/10W	R7156	1-216-841-11	METAL CHIP	47K 5% 1/10W
R7063	1-218-869-11	METAL CHIP	8.2K 0.5% 1/10W	R7158	1-216-833-11	METAL CHIP	10K 5% 1/10W
R7064	1-218-871-11	METAL CHIP	10K 0.5% 1/10W	R7501	1-216-864-11	SHORT CHIP	0
R7066	1-218-867-11	METAL CHIP	6.8K 0.5% 1/10W	R7505	1-216-864-11	SHORT CHIP	0
R7067	1-216-833-11	METAL CHIP	10K 5% 1/10W	R7600	1-216-864-11	SHORT CHIP	0
R7087	1-216-857-11	METAL CHIP	1M 5% 1/10W	R7601	1-216-829-11	METAL CHIP	4.7K 5% 1/10W
R7088	1-216-837-11	METAL CHIP	22K 5% 1/10W	R7602	1-216-829-11	METAL CHIP	4.7K 5% 1/10W
R7093	1-216-841-11	METAL CHIP	47K 5% 1/10W	R7603	1-218-873-11	METAL CHIP	12K 0.5% 1/10W
R7101	1-216-845-11	METAL CHIP	100K 5% 1/10W	R7604	1-218-875-11	METAL CHIP	15K 0.5% 1/10W
R7102	1-216-833-11	METAL CHIP	10K 5% 1/10W	R7605	1-216-841-11	METAL CHIP	47K 5% 1/10W
R7103	1-218-865-11	METAL CHIP	5.6K 0.5% 1/10W	R7606	1-216-841-11	METAL CHIP	47K 5% 1/10W
R7111	1-216-841-11	METAL CHIP	47K 5% 1/10W	R7614	1-216-833-11	METAL CHIP	10K 5% 1/10W
R7112	1-216-864-11	SHORT CHIP	0	R7615	1-218-873-11	METAL CHIP	12K 0.5% 1/10W
R7113	1-218-887-11	METAL CHIP	47K 0.5% 1/10W	R7620	1-218-871-11	METAL CHIP	10K 0.5% 1/10W
R7114	1-218-855-11	METAL CHIP	2.2K 0.5% 1/10W	R7621	1-218-863-11	METAL CHIP	4.7K 0.5% 1/10W
R7115	1-218-887-11	METAL CHIP	47K 0.5% 1/10W	R7622	1-218-863-11	METAL CHIP	4.7K 0.5% 1/10W
R7116	1-218-855-11	METAL CHIP	2.2K 0.5% 1/10W	R7623	1-218-871-11	METAL CHIP	10K 0.5% 1/10W
R7117	1-216-833-11	METAL CHIP	10K 5% 1/10W	R7626	1-216-845-11	METAL CHIP	100K 5% 1/10W
R7118	1-216-825-11	METAL CHIP	2.2K 5% 1/10W	R7627	1-216-845-11	METAL CHIP	100K 5% 1/10W
R7119	1-216-825-11	METAL CHIP	2.2K 5% 1/10W	R7628	1-216-844-11	METAL CHIP	82K 5% 1/10W
R7120	1-216-864-11	SHORT CHIP	0	R7629	1-216-827-11	METAL CHIP	3.3K 5% 1/10W
R7122	1-216-864-11	SHORT CHIP	0	R7630	1-216-827-11	METAL CHIP	3.3K 5% 1/10W
R7124	1-218-867-11	METAL CHIP	6.8K 0.5% 1/10W	R7631	1-216-844-11	METAL CHIP	82K 5% 1/10W
R7125	1-218-867-11	METAL CHIP	6.8K 0.5% 1/10W	R7632	1-218-887-11	METAL CHIP	47K 0.5% 1/10W
R7126	1-218-871-11	METAL CHIP	10K 0.5% 1/10W	R7633	1-218-887-11	METAL CHIP	47K 0.5% 1/10W
R7127	1-218-879-11	METAL CHIP	22K 0.5% 1/10W	R7634	1-218-855-11	METAL CHIP	2.2K 0.5% 1/10W
R7128	1-218-901-11	METAL CHIP	180K 0.5% 1/10W	R7635	1-218-855-11	METAL CHIP	2.2K 0.5% 1/10W
R7129	1-218-871-11	METAL CHIP	10K 0.5% 1/10W	R7636	1-216-837-11	METAL CHIP	22K 5% 1/10W
R7130	1-218-867-11	METAL CHIP	6.8K 0.5% 1/10W	R7637	1-216-857-11	METAL CHIP	1M 5% 1/10W
R7131	1-218-867-11	METAL CHIP	6.8K 0.5% 1/10W	R7639	1-216-845-11	METAL CHIP	100K 5% 1/10W
R7132	1-218-895-11	METAL CHIP	100K 0.5% 1/10W	R7641	1-216-825-11	METAL CHIP	2.2K 5% 1/10W
R7133	1-218-895-11	METAL CHIP	100K 0.5% 1/10W	R7642	1-216-825-11	METAL CHIP	2.2K 5% 1/10W
R7134	1-216-296-11	SHORT CHIP	0	R7643	1-216-845-11	METAL CHIP	100K 5% 1/10W
R7135	1-216-296-11	SHORT CHIP	0	R7644	1-216-813-11	METAL CHIP	220 5% 1/10W
R7136	1-216-296-11	SHORT CHIP	0	R7646	1-216-813-11	METAL CHIP	220 5% 1/10W
R7137	1-216-296-11	SHORT CHIP	0	R7650	1-216-841-11	METAL CHIP	47K 5% 1/10W
R7138	1-216-800-11	METAL CHIP	18 5% 1/10W	R7651	1-216-864-11	SHORT CHIP	0
R7139	1-216-800-11	METAL CHIP	18 5% 1/10W	R7652	1-216-864-11	SHORT CHIP	0
R7140	1-216-800-11	METAL CHIP	18 5% 1/10W	R7653	1-216-864-11	SHORT CHIP	0
R7141	1-216-800-11	METAL CHIP	18 5% 1/10W	R7654	1-216-841-11	METAL CHIP	47K 5% 1/10W
R7142	1-216-845-11	METAL CHIP	100K 5% 1/10W	R7655	1-216-829-11	METAL CHIP	4.7K 5% 1/10W



REF.NO.	PART.NO	DESCRIPTION	REMARK	REF.NO.	PART.NO	DESCRIPTION	REMARK
R7656	1-216-829-11	METAL CHIP	4.7K 5% 1/10W	R9041	1-216-864-11	SHORT CHIP	0
R7657	1-216-837-11	METAL CHIP	22K 5% 1/10W	R9042	1-216-809-11	METAL CHIP	100 5% 1/10W
R7658	1-216-857-11	METAL CHIP	1M 5% 1/10W	R9044	1-216-809-11	METAL CHIP	100 5% 1/10W
R7659	1-216-833-11	METAL CHIP	10K 5% 1/10W	R9045	1-216-809-11	METAL CHIP	100 5% 1/10W
R7660	1-216-841-11	METAL CHIP	47K 5% 1/10W	R9046	1-216-817-11	METAL CHIP	470 5% 1/10W
R7661	1-216-864-11	SHORT CHIP	0	R9047	1-216-813-11	METAL CHIP	220 5% 1/10W
R7662	1-216-841-11	METAL CHIP	47K 5% 1/10W	R9048	1-216-864-11	SHORT CHIP	0
R7663	1-216-833-11	METAL CHIP	10K 5% 1/10W	R9049	1-216-813-11	METAL CHIP	220 5% 1/10W
R7676	1-216-864-11	SHORT CHIP	0	R9050	1-216-864-11	SHORT CHIP	0
R7679	1-216-864-11	SHORT CHIP	0	R9051	1-216-809-11	METAL CHIP	100 5% 1/10W
R7682	1-216-864-11	SHORT CHIP	0	R9053	1-216-809-11	METAL CHIP	100 5% 1/10W
R7683	1-216-864-11	SHORT CHIP	0	R9054	1-216-809-11	METAL CHIP	100 5% 1/10W
R7684	1-216-864-11	SHORT CHIP	0	R9055	1-216-809-11	METAL CHIP	100 5% 1/10W
R7685	1-216-864-11	SHORT CHIP	0	R9056	1-216-817-11	METAL CHIP	470 5% 1/10W
R9001	1-216-864-11	SHORT CHIP	0	R9057	1-216-809-11	METAL CHIP	100 5% 1/10W
R9002	1-216-864-11	SHORT CHIP	0	R9058	1-216-809-11	METAL CHIP	100 5% 1/10W
R9005	1-218-285-11	METAL CHIP	75 5% 1/10W	R9059	1-216-809-11	METAL CHIP	100 5% 1/10W
R9006	1-218-285-11	METAL CHIP	75 5% 1/10W	R9060	1-218-879-11	METAL CHIP	22K 0.5% 1/10W
R9007	1-216-815-11	METAL CHIP	330 5% 1/10W	R9061	1-218-879-11	METAL CHIP	22K 0.5% 1/10W
R9008	1-216-821-11	METAL CHIP	1K 5% 1/10W	R9062	1-216-853-11	METAL CHIP	470K 5% 1/10W
R9009	1-216-815-11	METAL CHIP	330 5% 1/10W	R9063	1-216-853-11	METAL CHIP	470K 5% 1/10W
R9010	1-216-821-11	METAL CHIP	1K 5% 1/10W	R9064	1-216-853-11	METAL CHIP	470K 5% 1/10W
R9011	1-216-815-11	METAL CHIP	330 5% 1/10W	R9065	1-216-853-11	METAL CHIP	470K 5% 1/10W
R9012	1-216-821-11	METAL CHIP	1K 5% 1/10W	R9066	1-216-853-11	METAL CHIP	470K 5% 1/10W
R9013	1-216-815-11	METAL CHIP	330 5% 1/10W	R9067	1-216-853-11	METAL CHIP	470K 5% 1/10W
R9014	1-216-821-11	METAL CHIP	1K 5% 1/10W	R9068	1-216-853-11	METAL CHIP	470K 5% 1/10W
R9015	1-218-831-11	METAL CHIP	220 0.5% 1/10W	R9069	1-216-853-11	METAL CHIP	470K 5% 1/10W
R9017	1-218-831-11	METAL CHIP	220 0.5% 1/10W	R9070	1-218-873-11	METAL CHIP	12K 0.5% 1/10W
R9018	1-218-831-11	METAL CHIP	220 0.5% 1/10W	R9071	1-218-873-11	METAL CHIP	12K 0.5% 1/10W
R9019	1-218-831-11	METAL CHIP	220 0.5% 1/10W	R9072	1-216-821-11	METAL CHIP	1K 5% 1/10W
R9020	1-218-831-11	METAL CHIP	220 0.5% 1/10W	R9073	1-216-809-11	METAL CHIP	100 5% 1/10W
R9021	1-218-831-11	METAL CHIP	220 0.5% 1/10W	R9074	1-216-819-11	METAL CHIP	680 5% 1/10W
R9023	1-218-831-11	METAL CHIP	220 0.5% 1/10W	R9075	1-216-819-11	METAL CHIP	680 5% 1/10W
R9024	1-218-831-11	METAL CHIP	220 0.5% 1/10W	R9086	1-216-864-11	SHORT CHIP	0
R9025	1-218-831-11	METAL CHIP	220 0.5% 1/10W	R9088	1-216-849-11	METAL CHIP	220K 5% 1/10W
R9026	1-218-831-11	METAL CHIP	220 0.5% 1/10W	R9089	1-216-849-11	METAL CHIP	220K 5% 1/10W
R9027	1-218-831-11	METAL CHIP	220 0.5% 1/10W	R9095	1-216-864-11	SHORT CHIP	0
R9028	1-218-831-11	METAL CHIP	220 0.5% 1/10W	R9096	1-216-864-11	SHORT CHIP	0
R9029	1-218-831-11	METAL CHIP	220 0.5% 1/10W	R9104	1-216-864-11	SHORT CHIP	0
R9030	1-218-831-11	METAL CHIP	220 0.5% 1/10W	R9105	1-216-864-11	SHORT CHIP	0
R9031	1-218-831-11	METAL CHIP	220 0.5% 1/10W	R9106	1-216-864-11	SHORT CHIP	0
R9032	1-218-831-11	METAL CHIP	220 0.5% 1/10W	R9107	1-216-864-11	SHORT CHIP	0
R9033	1-218-831-11	METAL CHIP	220 0.5% 1/10W	R9109	1-218-831-11	METAL CHIP	220 0.5% 1/10W
R9034	1-218-831-11	METAL CHIP	220 0.5% 1/10W	R9110	1-218-831-11	METAL CHIP	220 0.5% 1/10W
R9035	1-218-831-11	METAL CHIP	220 0.5% 1/10W	R9111	1-218-831-11	METAL CHIP	220 0.5% 1/10W
R9036	1-218-831-11	METAL CHIP	220 0.5% 1/10W	R9112	1-218-831-11	METAL CHIP	220 0.5% 1/10W
R9037	1-216-821-11	METAL CHIP	1K 5% 1/10W	R9113	1-218-831-11	METAL CHIP	220 0.5% 1/10W
R9038	1-216-813-11	METAL CHIP	220 5% 1/10W	R9114	1-218-831-11	METAL CHIP	220 0.5% 1/10W
R9039	1-216-864-11	SHORT CHIP	0	R9115	1-216-801-11	METAL CHIP	22 5% 1/10W
R9040	1-216-813-11	METAL CHIP	220 5% 1/10W	R9116	1-216-801-11	METAL CHIP	22 5% 1/10W

REF.NO.	PART.NO	DESCRIPTION	REMARK	REF.NO.	PART.NO	DESCRIPTION	REMARK
R9117	1-216-801-11	METAL CHIP	22 5% 1/10W			< CRYSTAL >	
R9122	1-216-821-11	METAL CHIP	1K 5% 1/10W				
R9123	1-216-821-11	METAL CHIP	1K 5% 1/10W				
R9124	1-216-821-11	METAL CHIP	1K 5% 1/10W				
R9125	1-216-821-11	METAL CHIP	1K 5% 1/10W	X7000	1-795-612-11	VIBRATOR, CRYSTAL	
*A-1172-590-D H1E Board, Complete							
						< CONNECTOR >	
R9126	1-216-821-11	METAL CHIP	1K 5% 1/10W				
R9127	1-216-821-11	METAL CHIP	1K 5% 1/10W				
R9128	1-216-853-11	METAL CHIP	470K 5% 1/10W	CN101	*1-819-445-11	HEADER ASSEMBLY FOR PWB 3P	
R9129	1-216-853-11	METAL CHIP	470K 5% 1/10W				
R9130	1-216-815-11	METAL CHIP	330 5% 1/10W			< RESISTOR >	
R9131	1-216-815-11	METAL CHIP	330 5% 1/10W	R101	1-218-848-11	METAL CHIP 1.1K 0.5% 1/10W	
R9135	1-218-831-11	METAL CHIP	220 0.5% 1/10W	R102	1-218-841-11	METAL CHIP 560 0.5% 1/10W	
R9136	1-218-831-11	METAL CHIP	220 0.5% 1/10W	R103	1-218-835-11	METAL CHIP 330 0.5% 1/10W	
R9137	1-218-831-11	METAL CHIP	220 0.5% 1/10W	R104	1-218-831-11	METAL CHIP 220 0.5% 1/10W	
R9138	1-218-831-11	METAL CHIP	220 0.5% 1/10W	R105	1-218-827-11	METAL CHIP 150 0.5% 1/10W	
R9139	1-218-831-11	METAL CHIP	220 0.5% 1/10W			< SWITCH >	
R9140	1-218-831-11	METAL CHIP	220 0.5% 1/10W	S101	1-572-595-31	SWITCH, TACTIL (REFLOW TYPE)	
R9141	1-218-831-11	METAL CHIP	220 0.5% 1/10W	S102	1-572-595-31	SWITCH, TACTIL (REFLOW TYPE)	
R9142	1-218-831-11	METAL CHIP	220 0.5% 1/10W	S103	1-572-595-31	SWITCH, TACTIL (REFLOW TYPE)	
R9143	1-218-831-11	METAL CHIP	220 0.5% 1/10W	S104	1-572-595-31	SWITCH, TACTIL (REFLOW TYPE)	
R9144	1-218-831-11	METAL CHIP	220 0.5% 1/10W	S105	1-572-595-31	SWITCH, TACTIL (REFLOW TYPE)	
R9145	1-218-831-11	METAL CHIP	220 0.5% 1/10W	S106	1-572-595-31	SWITCH, TACTIL (REFLOW TYPE)	
R9146	1-218-831-11	METAL CHIP	220 0.5% 1/10W	S107	1-572-595-31	SWITCH, TACTIL (REFLOW TYPE)	
R9147	1-218-831-11	METAL CHIP	220 0.5% 1/10W				
R9150	1-216-864-11	SHORT CHIP	0				
R9151	1-216-864-11	SHORT CHIP	0				
R9152	1-216-864-11	SHORT CHIP	0				
R9153	1-216-864-11	SHORT CHIP	0				
R9154	1-216-864-11	SHORT CHIP	0				
R9155	1-216-864-11	SHORT CHIP	0				
R9156	1-216-864-11	SHORT CHIP	0				
R9157	1-216-864-11	SHORT CHIP	0				
R9158	1-216-864-11	SHORT CHIP	0				
R9501	1-216-864-11	SHORT CHIP	0				
R9502	1-216-864-11	SHORT CHIP	0				
R9506	1-216-864-11	SHORT CHIP	0				
R9541	1-216-864-11	SHORT CHIP	0				
R9546	1-216-809-11	METAL CHIP	100 5% 1/10W				
R9547	1-216-809-11	METAL CHIP	100 5% 1/10W				
< VARISTOR >							
VD9013	8-719-070-63	DIODE PDZ10B-115					
VD9014	8-719-070-63	DIODE PDZ10B-115					
VD9015	8-719-070-63	DIODE PDZ10B-115					
VD9016	8-719-070-63	DIODE PDZ10B-115					
VD9017	8-719-070-63	DIODE PDZ10B-115					
VD9018	8-719-070-63	DIODE PDZ10B-115					
VD9025	1-802-082-11	VARISTOR (SMD)					
VD9026	1-802-082-11	VARISTOR (SMD)					
*A-1172-592-D H3E Board, Complete							
						< CAPACITOR >	
				C302	1-162-960-11	CERAMIC CHIP 220PF	10.00% 50V
				C303	1-119-667-11	CERAMIC CHIP 22UF	10V
				C305	1-165-908-11	CERAMIC CHIP 1UF	10% 10V
				C307	1-107-826-11	CERAMIC CHIP 0.1UF	10.00% 16V
				C308	1-126-205-11	ELECT CHIP 47UF	20.00% 6.3V
						< CONNECTOR >	
				CN301	1-820-187-11	HEADER ASSEMBLY (PRINT PWB)10P	
						< DIODE >	
				D302	8-719-085-26	DIODE CL-165HR/SYG-D-T	
				D305	8-719-085-26	DIODE CL-165HR/SYG-D-T	
				D308	6-500-817-01	DIODE (LED) SML-512UWT86	
						< IC >	
				IC301	6-600-502-01	HIC GP1UE26RK0VF	
				IC302	6-600-447-01	IC TPS853 (SONY)	
						< TRANSISTOR >	
				Q301	8-729-028-96	TRANSISTOR DTC114EUA-T106	
				Q302	8-729-028-96	TRANSISTOR DTC114EUA-T106	
				Q303	8-729-028-96	TRANSISTOR DTC114EUA-T106	

REF.NO.	PART.NO	DESCRIPTION	REMARK	REF.NO.	PART.NO	DESCRIPTION	REMARK
Q304	8-729-028-96	TRANSISTOR DTC114EUA-T106				< SOCKET >	
Q305	8-729-028-96	TRANSISTOR DTC114EUA-T106					
Q306	8-729-602-36	TRANSISTOR 2SA1602-F		J201	1-780-368-11	S TERMINAL BLOCK (RIGHT ANGLE)	
		< RESISTOR >		J202	1-815-325-11	JACK	
R301	1-216-819-11	METAL CHIP 680 5%	1/10W			< RESISTOR >	
R302	1-216-815-11	METAL CHIP 330 5%	1/10W	R202	1-216-864-11	SHORT CHIP	0
R303	1-216-819-11	METAL CHIP 680 5%	1/10W	R205	1-216-821-11	METAL CHIP	1K 5% 1/10W
R304	1-216-815-11	METAL CHIP 330 5%	1/10W	R206	1-216-821-11	METAL CHIP	1K 5% 1/10W
R305	1-216-823-11	METAL CHIP 1.5K 5%	1/10W	R207	1-218-831-11	METAL CHIP	220 0.5% 1/10W
R306	1-216-817-11	METAL CHIP 470 5%	1/10W	R208	1-218-831-11	METAL CHIP	220 0.5% 1/10W
R307	1-216-805-11	METAL CHIP 47 5%	1/10W	R209	1-218-285-11	METAL CHIP	75 5% 1/10W
R309	1-216-839-11	METAL CHIP 33K 5%	1/10W	R210	1-218-831-11	METAL CHIP	220 0.5% 1/10W
R310	1-216-821-11	METAL CHIP 1K 5%	1/10W	R211	1-218-831-11	METAL CHIP	220 0.5% 1/10W
R311	1-216-833-11	METAL CHIP 10K 5%	1/10W	R212	1-216-797-11	METAL CHIP	10 5% 1/10W
R313	1-216-849-11	METAL CHIP 220K 5%	1/10W	R213	1-216-821-11	METAL CHIP	1K 5% 1/10W
R314	1-216-849-11	METAL CHIP 220K 5%	1/10W	R214	1-216-821-11	METAL CHIP	1K 5% 1/10W
R315	1-216-864-11	SHORT CHIP	0	R215	1-216-809-11	METAL CHIP	100 5% 1/10W
R316	1-216-827-11	METAL CHIP 3.3K 5%	1/10W	R216	1-216-809-11	METAL CHIP	100 5% 1/10W
*A-1152-233-D H2E Board, Complete (32/40 inch only)							
		< CAPACITOR >		R217	1-216-821-11	METAL CHIP	1K 5% 1/10W
C201	1-162-964-11	CERAMIC CHIP 0.001UF	10.00% 50V	R218	1-216-821-11	METAL CHIP	1K 5% 1/10W
C202	1-162-964-11	CERAMIC CHIP 0.001UF	10.00% 50V	R219	1-216-809-11	METAL CHIP	100 5% 1/10W
C203	1-127-573-11	CERAMIC CHIP 1UF	10% 16V	R220	1-216-797-11	METAL CHIP	10 5% 1/10W
C204	1-127-573-11	CERAMIC CHIP 1UF	10% 16V	R222	1-216-853-11	METAL CHIP	470K 5% 1/10W
C205	1-125-891-11	CERAMIC CHIP 0.47UF	10.00% 10V	R223	1-216-853-11	METAL CHIP	470K 5% 1/10W
C206	1-125-889-91	CERAMIC CHIP 2.2UF	10% 10V	R224	1-218-831-11	METAL CHIP	220 0.5% 1/10W
C207	1-125-889-91	CERAMIC CHIP 2.2UF	10% 10V	R225	1-218-831-11	METAL CHIP	220 0.5% 1/10W
C208	1-125-889-91	CERAMIC CHIP 2.2UF	10% 10V			< VARISTOR >	
C209	1-162-927-11	CERAMIC CHIP 100PF	5.00% 50V	VD201	1-802-082-11	VARISTOR (SMD)	
C210	1-164-227-11	CERAMIC CHIP 0.022UF	10.00% 25V	VD202	1-802-082-11	VARISTOR (SMD)	
C211	1-162-927-11	CERAMIC CHIP 100PF	5.00% 50V	VD203	1-802-082-11	VARISTOR (SMD)	
C212	1-164-227-11	CERAMIC CHIP 0.022UF	10.00% 25V				
C215	1-115-416-11	CERAMIC CHIP 0.001UF	5.00% 25V				
		< CONNECTOR >					
CN201	1-820-192-11	HEADER ASSEMBLY (PRINT PWB)15P					
		< DIODE >					
D201	8-719-070-63	DIODE PDZ10B-115					
D202	8-719-070-63	DIODE PDZ10B-115					
D203	8-719-070-63	DIODE PDZ10B-115					
D204	8-719-070-63	DIODE PDZ10B-115					
D205	8-719-070-63	DIODE PDZ10B-115					
D206	8-719-070-63	DIODE PDZ10B-115					

Note : The components identified by shading and marked Δ are critical for safety. Replace only with the part numbers specified in the parts list.

REF.NO.	PART.NO	DESCRIPTION	REMARK	REF.NO.	PART.NO	DESCRIPTION	REMARK
MISCELLANEOUS				*1-910-027-15	CONNECTOR ASSY 3P (CN1007-CN101(1))		(40S2510/30 UK/AEP)
	1-826-363-11	LOUDSPEAKER (4.2X15CM)		*1-910-030-59	CONNECTOR ASSY 15P (CN9001-CN201(1))		(40S2510/30 UK/AEP)
		(32S2510/S2520/S2530 UK/AEP)		*1-910-025-84	CONNECTOR ASSY 3P (CN101-CN1007(1))		(46S2510/30 UK/AEP)
	1-826-362-11	LOUDSPEAKER (5.5X15.5CM) (40S2510/S2530 UK/AEP)		*1-910-025-86	CONNECTOR ASSY 10P (CN301-CN1008(1))		(46S2510/30 UK/AEP)
	1-826-435-11	LOUDSPEAKER (13X7CM) (46S2510/S2530 UK/AEP)		*1-910-025-88	CONNECTOR ASSY 14P (CN6200-CN1002(1), CN6200-CN7503(0)) (46S2510/30 UK/AEP)		
	1-802-261-11	LCD PANEL (32S2510/S2520/S2530 UK/AEP)		*1-910-025-89	CONNECTOR ASSY 12P (CN6202-CN401(1), CN6202-CN7009(0)) (46S2510/30 UK/AEP)		
	1-802-267-11	LCD PANEL (40S2510/S2530 UK/AEP)		*1-910-025-90	CONNECTOR ASSY 10P (CN6204-CN201(1))		(46S2510/30 UK/AEP)
	1-802-133-41	LCD PANEL (46S2510/S2530 UK/AEP)		*1-910-026-77	CONNECTOR ASSY 15P (CN201-CN9001(1))		(46S2510/30 UK/AEP)
	8-597-598-00	TUNER UNIT, DIGITAL BTD-HF441Z		*1-910-027-05	SP CONNECTOR ASSY (CN7000-SPEAKER L(1), CN7000-SPEAKER R(0)) (46S2510/30 UK/AEP)		
	△ 1-819-729-14	INLET, AC (WITH NOISE FILTER)		2-894-287-11	INSTRUCTION MANUAL (UK) (ENGLISH)		
	*1-468-980-21	G1 BOARD COMPLETE	(32S2510/S2520/S2530 UK/AEP)	2-894-287-21	INSTRUCTION MANUAL (AEP) (GERMAN/FRENCH/ITALIAN/DUTCH)		
	△ 1-832-210-11	POWER-SUPPLY CORD SET	(32S2510/S2520/S2530 & 40/46S2510/S2530 UK)	2-894-287-31	INSTRUCTION MANUAL (AEP) (SPANISH/PORTUGUESE/GREEK)		
	△ 1-832-211-11	POWER-SUPPLY CORD SET	(32S2510/S2520/S2530 & 40/46S2510/S2530 AEP)	2-894-287-41	INSTRUCTION MANUAL (AEP) (ENGLISH/RUSSIAN/POLISH)		
				2-894-287-51	INSTRUCTION MANUAL (AEP) (SWEDISH/DANISH/FINNISH/NORWEGIAN)		
ACCESSORIES AND CONNECTORS				REMOTE COMMANDER			
	1-769-175-21	ANTENNA CABLE		1-479-978-11	REMOTE COMMANDER (RM-ED008)		
	*1-832-389-11	HARNESS WITH CONNECTOR (LVDS) (CN101-CN5000(1))					
	*1-910-025-32	CONNECTOR ASSY 6P (CN3904-CN7501(1))					
	*1-910-025-33	CONNECTOR ASSY 7P (CN3401-CN7502(1))					
	*1-910-025-35	CONNECTOR ASSY 30P (CN3600-CN3901(1))					
	*1-910-025-36	CONNECTOR ASSY 9P (CN7008-CN9502(1))					
	*1-910-025-37	CONNECTOR ASSY 10P (CN1700-CN3903(1))					
	*1-910-025-38	CONNECTOR ASSY 1P (R VESA-G2 BOARD (1))					
	*1-910-025-39	CONNECTOR ASSY (FFC) 20P (CN4700-CN3400(1))					
	*1-910-025-63	FFC CONNECTOR ASSY 49P (CN1001-CN9501(1))					
	*1-910-027-14	CONNECTOR ASSY 12P (CN1701-CN3802(1))					
	*1-910-025-76	CONNECTOR ASSY 3P (CN1007-CN101(1))	(32S2510/20/30 UK/AEP)				
	*1-910-025-77	CONNECTOR ASSY 10P (CN1008-CN301(1))	(32S2510/20/30 UK/AEP)				
	*1-910-025-78	CONNECTOR ASSY 14P (CN6202-CN1002(1), CN6202-CN7503(0)) (32S2510/20/30 UK/AEP)					
	*1-910-025-79	CONNECTOR ASSY 12P (CN6203-CN7009(1), CN6203-CN8001(0)) (32S2510/20/30 UK/AEP)					
	*1-910-026-79	SP CONNECTOR ASSY (CN7000-SP, RL(1))	(32S2510/20/30 UK/AEP)				
	*1-910-028-20	CONNECTOR ASSY 15P (CN9001-CN201(1))	(32S2510/20/30 UK/AEP)				
	*1-910-025-81	CONNECTOR ASSY 10P (CN1008-CN301(1))	(40S2510/30 UK/AEP)				
	*1-910-025-82	CONNECTOR ASSY 14P (CN6200-CN1002(1), CN6200-CN7503(0)) (40S2510/30 UK/AEP)					
	*1-910-025-83	CONNECTOR ASSY 12P (CN6202-CN7009(1), CN6202-CN-1(0)) (40S2510/30 UK/AEP)					
	*1-910-026-78	SP CONNECTOR ASSY (CN7000-SP, RL(1))	(40S2510/30 UK/AEP)				

